

SFE3 Manual

© 2008 by Fairford Electronics, all rights reserved

Copyright subsists in all Fairford Electronics deliverables including magnetic, optical and/or any other soft copy of these deliverables. This document may not be reproduced, in full or in part, without written permission. Enquiries about copyright of Fairford Electronics deliverables should be made to Fairford Electronics, Coombe Works, Derby Road, Kingsbridge, Devon TQ7 1JL.

If, by permission of the copyright owner, any part of this document is quoted, then a statement specifying the original document shall be added to the quotation. Any such quotation shall be according to the original (text, figure or table) and may not be shortened or modified.

Sections (click on the title to go to the page)

Title	Page Number
SFE3 Basic Guide	3
SFE3-O	11
Mechanical Installation	17
Electrical Installation	27
Applications Manual	53
EMC Manual	77
Applications Data	85
Flag Data	89
Bit Parameters	91
Technical Hints	114
Programming Guide	117
Modbus Protocol Manual	183
Communications Brochure	194
Keypod Brochure	196
Communication Application Note	198

Guide to contents - applicable to

5MC software V55

1 Mechanical Outlines

Referring to the appropriate size of SFE3, mount the SFE3 ensuring that correct clearances are maintained for adequate ventilation and operation of the SFE3.

2 Wiring Diagrams

Referring to the appropriate **Wiring Diagram**, install the SFE3 electrical connections ensuring that the correct control supply voltage is used and is within its specified operating limits as described on the product specification

ACCESS

Caution Always replace the cover panel on the unit after gaining access to the electrical connections.

The unit requires two AC supplies:

A 3 phase balanced Mains Supply to provide the source of power for the controlled motor.

A single phase supply: 115V/230V, 50Hz/60Hz, for the internal control circuitry.

IMPORTANT Ensure that the voltage selector switch position corresponds to the control supply before you apply the control supply voltage.



ISOLATION

Caution: The SFE3 uses semiconductor devices in the main circuit and is not designed to provide isolation. For this reason isolation means must be installed in the supply circuit in accordance with the appropriate wiring and safety regulations.

The Mains Supply and the Control Supply each require protection. Although all units have electronic overload protection, the installer should always place fuse protection **between** the unit and the Mains Supply, **not between** the unit and the motor. Semiconductor fuses can be supplied for short circuit protection of the semiconductors.

3 Keypad operation and basic set-up

Refer to this, for familiarisation with the keypad controls of the SFE3. Use the illustration of the Basic Menu structure to find SFE3 menu items on the display.

4 Set-up examples

Set-up basic SFE3 operating parameters, if necessary, by following one or all of the examples described here.

5 Product information

Refer to product information for details of Design Standards and Approvals, operating and storage limits and other installation instructions.

Further Information

For further information about the SFE3 soft start motor controller, more detailed SFE3 manuals and application notes are available from your supplier (see back page for contact details).

1 Mechanical Outlines

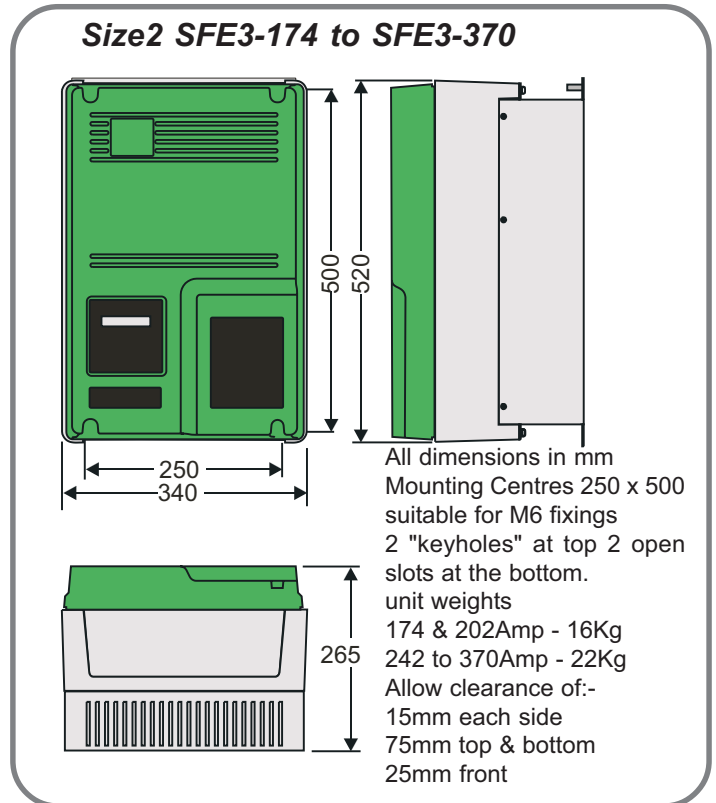
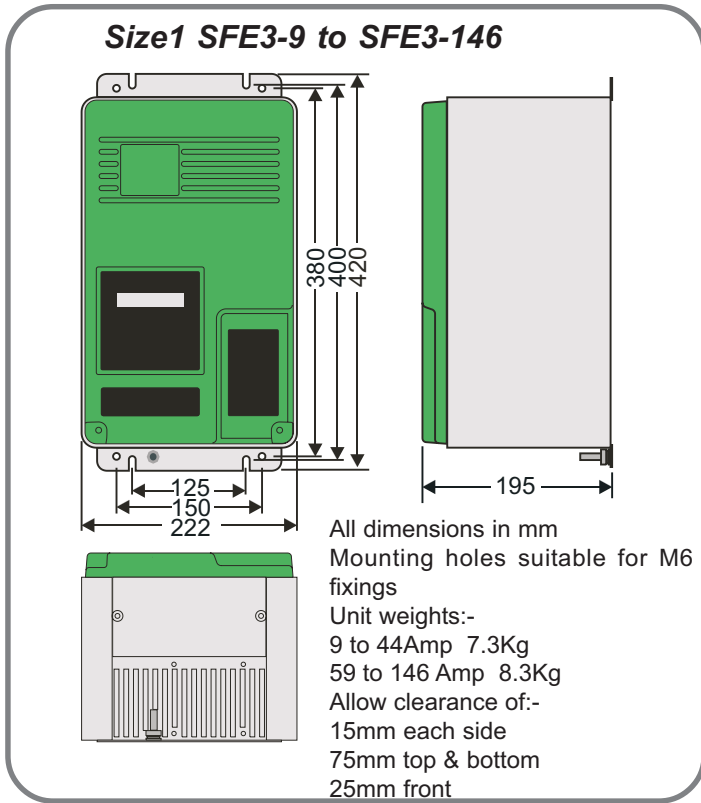

Note 1: - Chassis size 2

To allow for larger cross sections of insulated cable on models of SFE3 in chassis size 2, extended gland plates are available as an option.

Note 2: - Chassis size 3

When fitting the unit into a cabinet, allowance must be made for 90° opening of the hinged unit doors.

Add 90mm for the left-hand door which has the plastic moulding incorporating the control card and keypad, and 30mm for the right hand door i.e. 90 + 675 + 30 = 795mm as an overall cabinet opening.

Note 3: - Enclosures

When fitting a SFE3 into a cabinet, ventilation must be provided if the heat output of the unit is greater than the cabinet will dissipate.

Use the following formula to determine the fan requirement. An allowance has been incorporated into the formula so that the figure for "Q" is the air delivery quoted in the fan suppliers data.

An approximation of the heat produced by the SFE3 (in Watts) can be made by multiplying the full load line current by three. Exact figures for unit full load current are in the SFE3 manual.

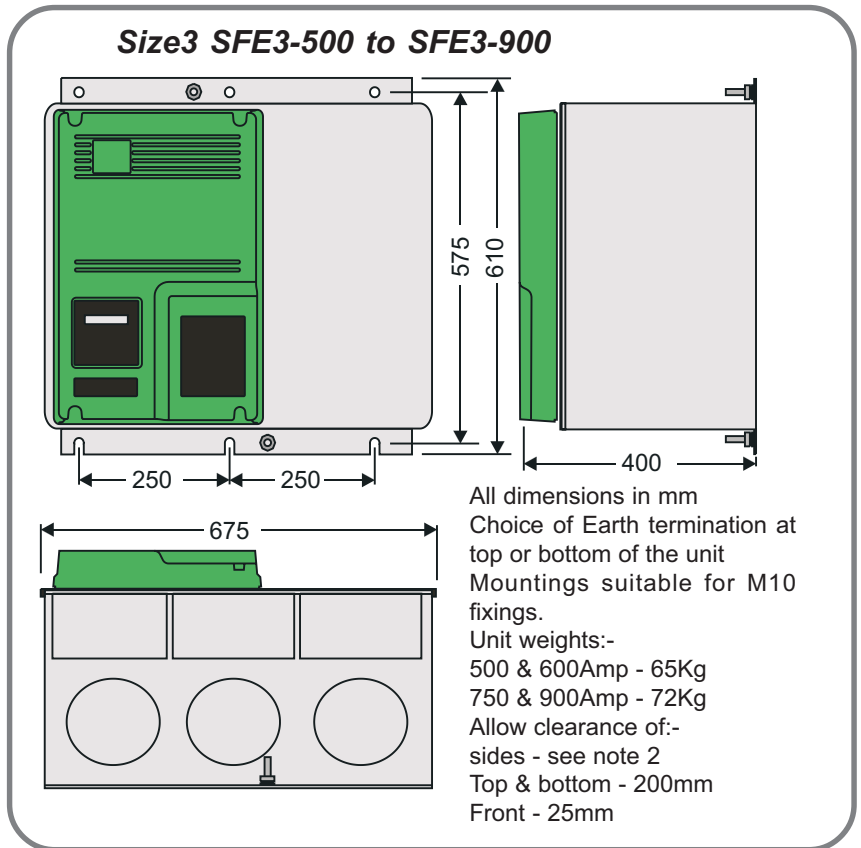

$$Q = \frac{4 \times Wt}{(t_{max} - t_{amb})}$$

- Q = required volume of air (cubic metres per hour - m³/h)
 - Wt = heat produced by the unit and all other heat sources within the enclosure (Watts)
 - t_{max} = maximum permissible temperature within the enclosure (40°C for a fully rated SFE3)
 - t_{amb} = temperature of the air entering the enclosure (°C)
- If you prefer to work in CFM, substitute °F for °C. Q is now in CFM.

2 Wiring Diagrams

Fig 2.1 Control circuit wiring

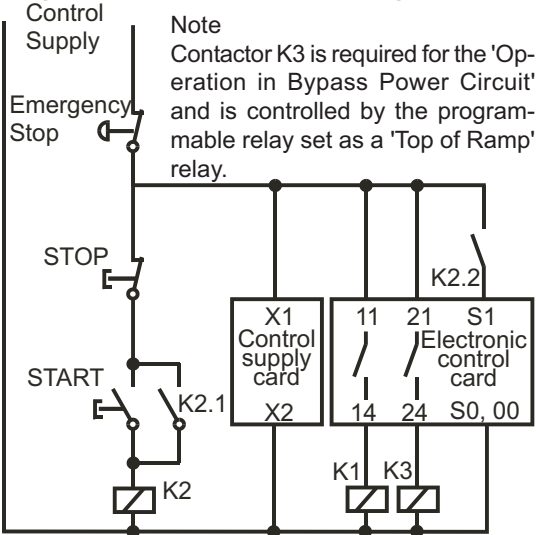

Note: Extra X1 and X2 on Size 3 for fan supply

The **Electronic control card** is located underneath the cover in the Size 1 and 2 units and inside the hinged door panel in Size 3 units. Connections shown in the control circuit wiring diagram are made to the electronic control card terminals as shown in fig.2.2 below.

Fig 2.2

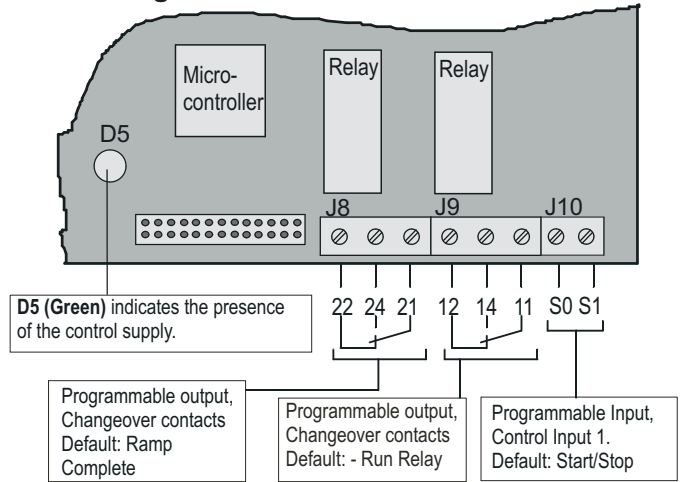

Use the control circuit with one of these power circuits

Fig 2.3 Power circuit for In-Line connection of motors (see note 3).

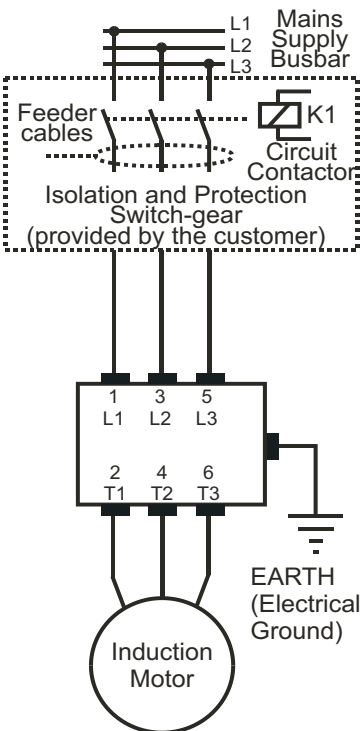
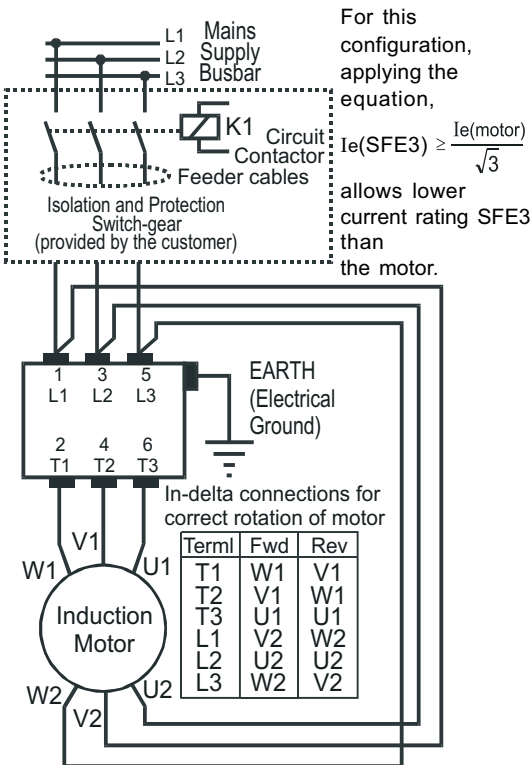
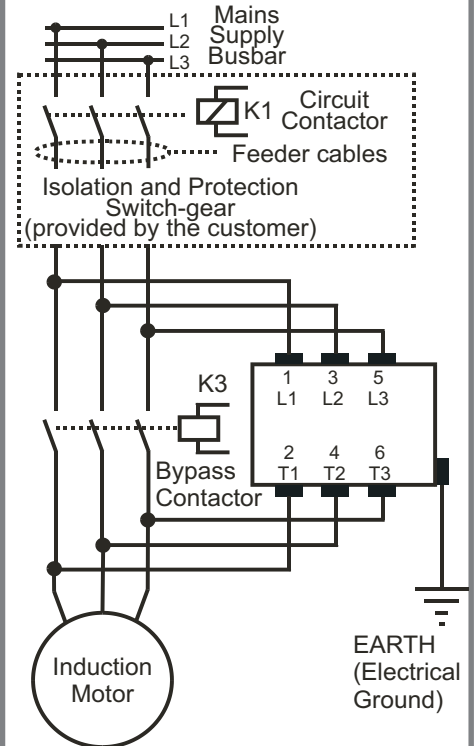

Fig 2.4 Power circuit for In-Delta connection of motors (see note 4).



For this configuration, applying the equation,
$$I_e(SFE3) \geq \frac{I_e(\text{motor})}{\sqrt{3}}$$
allows lower current rating SFE3 than the motor.

Fig 2.5 Power circuit for bypass operation (see note 5).



Important

- Note 1: Correction capacitors:**
Power factor correction capacitors must **NOT** be positioned on the output of the power circuit.
- Note 2: Fuse Selection:**
Where semiconductor type fuses are required, they should be selected from the table in Section 5.
- Note 3:** The in-line configuration shown in Fig 2.3 requires that the firing mode be set to '0'.
- Note 4:** The **In-Delta configuration** as in Fig 2.4 requires that the Firing Mode be set to '1'.
An in-line contactor controlled by the starter **MUST** be used with the In-Delta firing mode.
- Note 5:** The **bypass configuration** as in Fig 2.5 is automatically detected as "Auto bypass" is set as default.

3 Keypad operation and basic set-up

ALWAYS ENSURE THAT THE KEYPAD CABLE IS PLUGGED IN BEFORE APPLYING POWER TO THE UNIT

When wired as Fig 2.1, page 3, the SFE3 display will indicate start up messages followed by 'Stopped and ready'. At this point:

- the SFE3 will start the motor when the keypad 'START/STOP' key is pressed but not when the START switch as shown in Fig.2.1 is closed.
- the SFE3 parameters are set to factory default which may not be ideal for the required application.

The examples in section 4 show how to set up some of the essential SFE3 operating parameters using the keypad. Once these are understood, other SFE3 settings, as indicated in the programming Menu Structure below, can be set in a similar manner (The corresponding default settings are shown in brackets). For the full menu structure, refer to the SFE3 Manual.

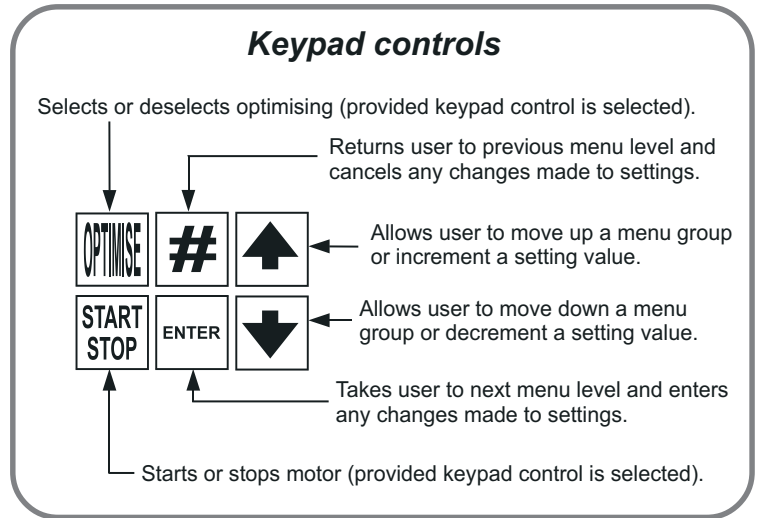

Menu structure *Typical Keypad menu. contact your supplier for details.*

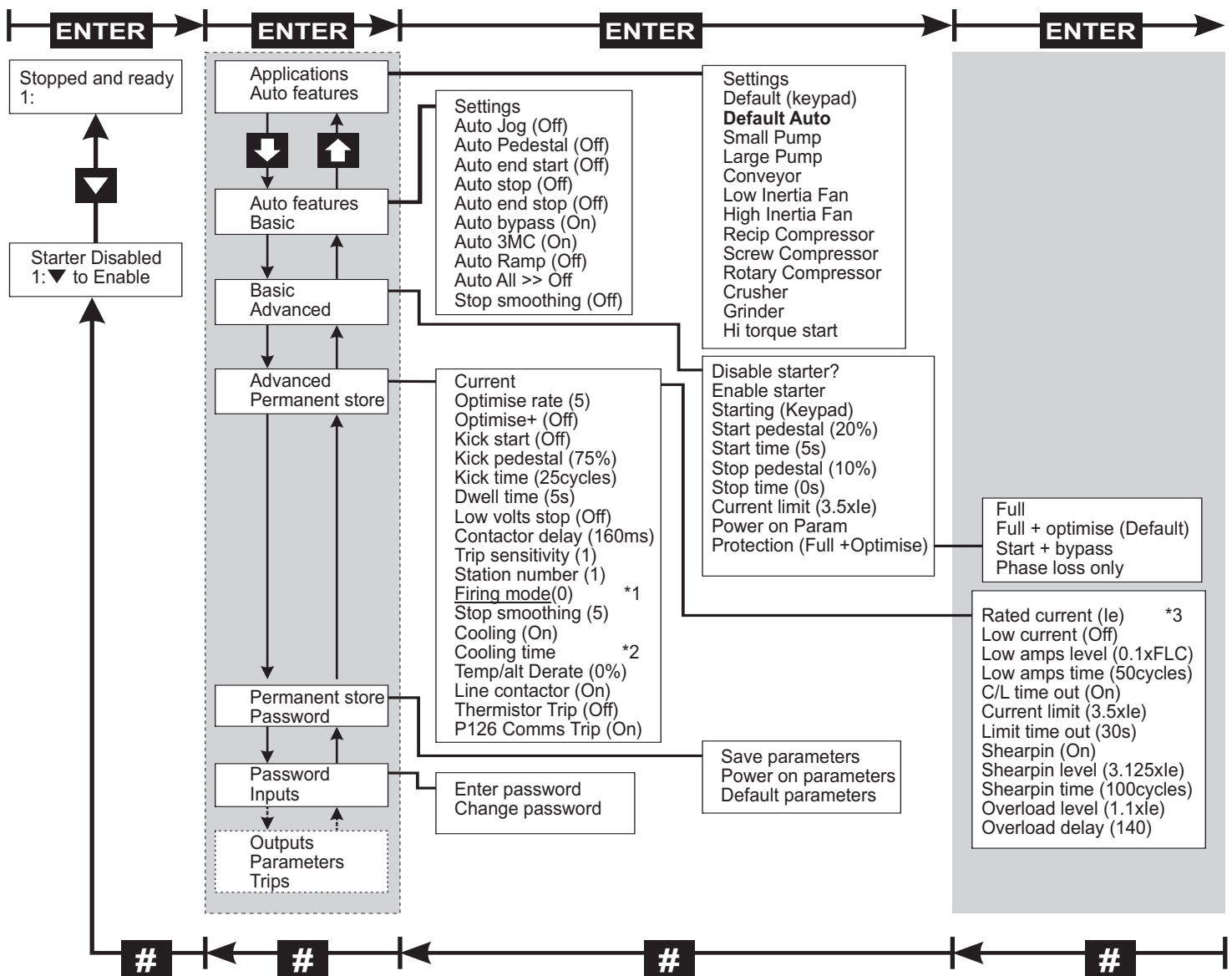

*1 The "Firing mode" must be set to '1' for the In-Delta configuration.

*2 The "Cooling time" is dependant on the Model range, Duty rating and Heatsink temperature.

*3 The "Rated current" setting is for reference only and is not user adjustable.

Starter Enable/Disable

An additional safety feature has been added so that following certain actions the starter will be disabled. It is strongly recommended that before any changes to parameter values are made, that the starter is **disabled** via the **Basic Menu**. Once disabled, the starter remains unable to drive the load, until it has been **enabled** via the **Basic Menu**, or the control supply is removed and reapplied, or the ▼ key is pressed when prompted.

4 Set-up examples

1 Setting the SFE3 for large pump application

- ① With 'Starter Disabled' shown on the display, press **ENTER** key once.
- ② With 'Applications' shown on the top line of the display press **ENTER** once.
- ③ With 'Settings' shown at the top of the display press **↓** key three times until 'Large pump' is shown at top of display.
- ④ Press **ENTER** once to select large pump. The display will indicate the parameters changing in short intervals.
- ⑤ With the display top line indicating 'Send to store?', press **ENTER** to save the settings for a large pump to permanent store. Display will flash the message 'Storing' twice to indicate this has been done.
- ⑥ At any of the above stages pressing **#** will return the user to the previous menu. The SFE3 will not start until the control display indicates 'Stopped and ready'.

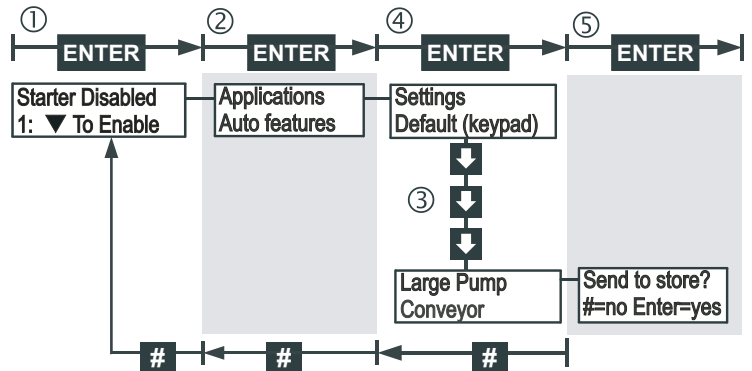

2 Setting the SFE3 for remote starting and stopping.

- ① With 'Starter Disabled' shown on the display, press **ENTER** key once.
- ② With 'Applications' shown on the top line of the display press **↓** key twice until 'Basic' is shown at the top of the display.
- ③ Press **ENTER** once to select Basic menu.
- ④ Press **↓** key twice until 'Starting' is shown at top of the display then press **ENTER** once to select starting option menu.
- ⑤ With display now indicating 'Starting' on top line press **ENTER** to toggle from 'Keypad Starting' to 'Remote Starting' as shown on bottom line of display.
- ⑥ At any of the above stages pressing **#** will return the user to the previous menu.

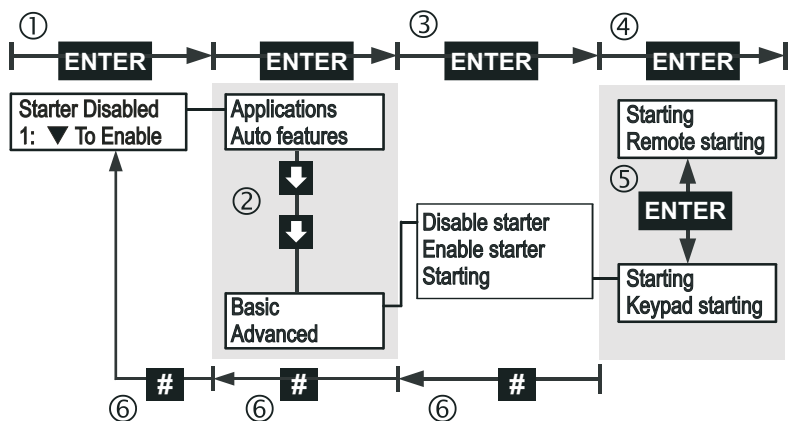

The SFE3 will now start and stop remotely from the START and STOP switches shown in Figure 2.1, but will return to keypad starting if the control supply on terminals X1 and X2 is removed. Alternatively, to return to keypad starting and stopping, repeat the above procedure and select 'Keypad Starting' at step 5. **To keep the remote start/stop setting after removal of the control supply, the settings must be permanently saved (See 3 below).**

3 Permanently saving parameters set by user.

- ① With 'Starter Disabled' shown on the display, press **ENTER** key once.
- ② With 'Applications' shown on the top line of the display press **↓** key four times until 'Permanent Store' is shown at top of display.
- ③ Press **ENTER** once to select Permanent Store menu.
- ④ With 'Save Param' shown at top of display press **ENTER** once to permanently save parameters. Display will flash twice to indicate this has been done.
- ⑤ At any of the above stages pressing **#** will return the user to the previous menu.

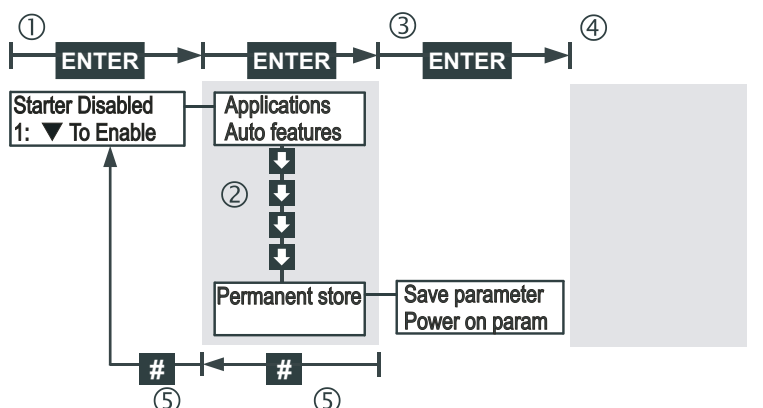

5 Product information

5.1 Design standards and Approvals

IEC 60947-4-2; EN 60947-4-2 'AC Semiconductor Motor Controllers and Starters'.

5.2 Basic ratings

	Connector/ terminal	SFE3 range	SFE3-G range	SFE3-E range	Rated freq.
Rated operational voltage	L1,L2,L3	230-460V AC rms (-15% +10%)	400-575V AC rms (-15% +10%)	500-690V AC rms (-15% +10%)	50/60Hz (±2Hz)
Control supply voltage (Us)	X1,X2	115V or 230V AC rms (-15% + 10%)			
Control input voltage (Uc)	S0,S1	12V/24VDC or 115/230VAC			
Output relays	11,12,14 and 21,22,24	AC1 230V, 3A			
Rated operational current(Ie)	See Semiconductor Fuse types table in Section 5.3				
Form designation	Form 1				

Index Ratings

In line with the stated IEC starting duties, starters of 242 Amps and above have an enforced off period of 7 minutes set as standard. During this period the display indicates "Stopped. Cooling", and the starter will not respond to a start signal.

Model name	Ie (A)	Standard operation AC-53a: X-Tx: F-S	Bypassed operation AC-53b: X-Tx: OFF-time
SFE3-9 to SFE3-105	9A to 105A	AC-53a: 5-4: 99-10 AC-53a: 3-35 :99-10	AC-53b: 5-4: 120 AC-53b: 3-35 :120
SFE3-146 to SFE3-202	146A to 202A	AC-53a: 4-6: 99-10 AC-53a: 3-35 :99-10	AC-53b: 4-6: 120 AC-53b: 3-35 :120
SFE3-242 to SFE3-900	242A to 900A	AC-53a: 4-6: 60-3 AC-53a: 3-35 :60-3	AC-53b: 4-6: 360 AC-53b: 3-35 : 360

Further Information

Document No TF0120 'Guide to Soft Start Drive Product Information', describes the rating index and the meaning of other IEC 60947-4-2 product information in more detail. This is available upon request from your supplier.

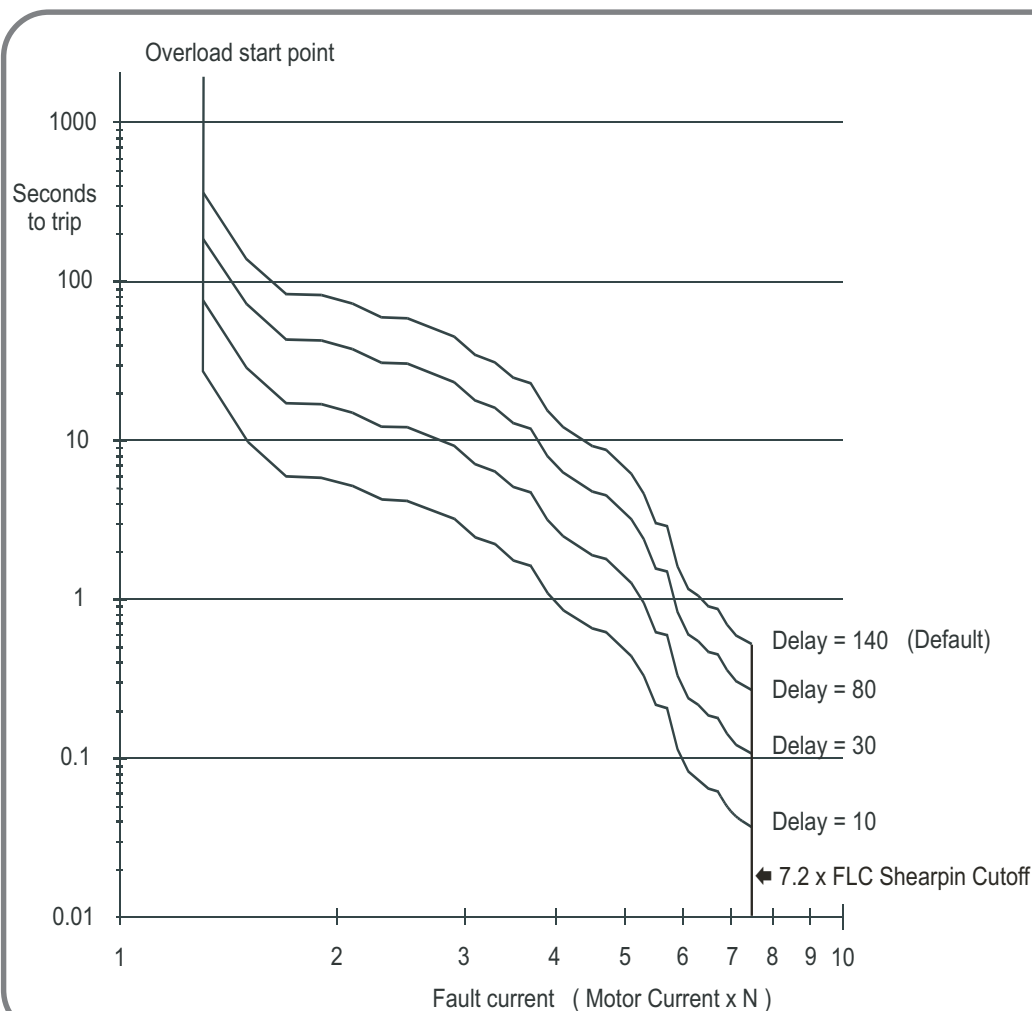

'Current limit', 'Overload level' and 'Overload delay' settings may be adjusted to limit overload currents in accordance with the trip curves shown here (See Menu structure in Section 3 for default settings). For motors with FLC's lower than the rated current of the SFE3 the 'Overload level' may be adjusted using the following formula:

$$\text{Overload level} = \text{Motor FLC} \times 1.1(\text{A})$$

Note: The overload monitors one of the phases only and the 'Current Limit' level is only active during motor starting.

IMPORTANT

It is recommended that the control supply is maintained between starts to ensure the integrity of the overload, which will reset on its removal.

5.3 Safety and installation.

Rated insulation voltage (Ui)	690V
Ingress Protection	IP20
Pollution degree	3
Short circuit co-ordination	Type 1

UL requires Recognized special purpose fuses (JFHR2), for the protection of semi-conductor devices, rated 700 Vac, as indicated in Table 5.3, be used to obtain the short circuit ratings required by UL.

Suitable for use on a circuit capable of delivering not more than the RMS Symmetrical Amperes indicated in Table 5.3 at maximum rated operational voltage, when protected by Semiconductor Fuse type, Manufactured by Company and Mod. No. indicated in Table 5.3. Fuse rated 700 Vac, Amps as indicated in Table 5.3.

These fuses are for short circuit protection of the semiconductors and must be mounted externally by the user **between** the unit and the mains supply, **not between** the unit and the motor.

Table 5.3 Semiconductor Fuse types

Model Name	I _e (Arms)	Short Circuit Amp RMS (kA)	UL Recognized JFHR2 Fuses		
			Bussman International Inc. Mod. No.	Ferraz Mod. No. 6.6 URD followed by	Amps
SFE3-9	9A	5	170M3110	30 D08A 0063	63
SFE3-16	16A	5	170M3110	30 D08A 0063	63
SFE3-23	23A	5	170M3112	30 D08A 0100	100
SFE3-30	30A	5	170M3112	30 D08A 0100	100
SFE3-44	44A	5	170M3114	30 D08A 0160	160
SFE3-59	59A	5	170M3115	30 D08A 0200	200
SFE3-72	72A	10	170M3116	30 D08A 0250	250
SFE3-85	85A	10	170M3116	30 D08A 0250	250
SFE3-105	105A	10	170M3119	30 D08A 0400	400
SFE3-146	146A	10	170M3119	30 D08A 0400	400
SFE3-174	174A	10	170M3121	30 D08A 0500	500
SFE3-202	202A	10	170M3121	30 D08A 0500	500
SFE3-242	242A	10	170M4114	31 D08A 0500	500
SFE3-300	300A	18	170M4114	31 D08A 0500	500
SFE3-370	370A	18	170M4116	31 D08A 0630	630
SFE3-500	500A	18	170M6113	33 D08A 0900	900
SFE3-600	600A	30	170M6113	33 D08A 0900	900
SFE3-750	750A	30	170M6116	33 D08A 1250	1250
SFE3-900	900A	42	170M6116	33 D08A 1250	1250

Application Note for fuse selection: APP00004

5.4 Normal service conditions.

Ambient temperature	0°C to 40°C. Above 40°C de-rate linearly by 2% of unit FLC per °C to a maximum of 40% at 60°C.
Transport and Storage	-25°C to +60°C (continuous), -25°C to +75°C (not exceeding 24 hours).
Altitude	1000m. Above 1000m de-rate linearly by 1% of unit FLC per 100m to a maximum altitude of 2000m.
Humidity	max. 85% non-condensing, not exceeding 50% at 40°C.

5.5 EMC Emission and Immunity levels

EMC compliance is in accordance with EN 60947-4-2 which refers to the following basic standards:

	Basic standard	Level
IMMUNITY Severity level 3	IEC 61000-4-2 IEC 61000-4-6 IEC 61000-4-3 IEC 61000-4-4 IEC 61000-4-5	6kV contact or 8kV air discharge 140dBuV over 0.15-80MHz 10V/m over 80 -1000MHz 2kV/5kHz 2kV line to ground and 1kV line to line
EMISSION Equipment Class A (Industrial)	EN 55011	Class A

Note: EN 60947-4-2 is published as a harmonized standard under European Council Directive No.89/336/EEC in relation to the electromagnetic compatibility. (Official Journal of the European Communities ref. 97/C 270/06)

5.6 Control, Power and Earth terminations.

Control Terminations

All models - Terminals	Terminal type	Wire type	Cable cross section				Terminal tightening torque
			AWG		mm ²		
			Min.	Max.	Min.	Max.	
X1,X2, S0,S1 11,12,14 21,22,24	Screw clamp terminals	Solid or stranded.	22	14	0.3	2.5	4.4 lb.in. (0.5 Nm.)

Control, Power and Earth terminations, continued

Power and Earth Terminations

Size 1: SFE3-9 to SFE3-146 terminals		Terminal type	Conductor type	Cable cross section*		Terminal tightening torque
				AWG	mm ²	
Power	L1, L2, L3, T1, T2, T3.	M8 metric threaded studs	Use 75°C copper (CU) conductor only and the wire shall be fitted with close eyelet lug.	1/0	50	106 lb.in. (12 Nm.)
Ground	PE 	M8 metric threaded stud				

Size 2: SFE3-174 to SFE3-370 terminals		Terminal type	Conductor type	Cable cross section*		Busbar size (mm)*	Terminal tightening torque
				AWG	mm ²		
Power	L1, L2, L3, T1, T2, T3.	M8 metric threaded studs	Use 75°C copper (CU) conductor only and the wire shall be fitted with close eyelet lug or use busbar.	2 x 250MCM	2 x 120	20 x 6	106 lb.in. (12 Nm.)
Ground	PE 	M8 metric threaded stud					

Size 3: SFE3-500 to SFE3-900 terminals		Terminal type	Conductor type	Busbar size (mm)*		Terminal tightening torque
Power	L1, L2, L3, T1, T2, T3.	Two off M10 nuts and bolts	Use Busbar	45 x 20	60 x 10 80 x 10	212 lb.in. (24 Nm.)
Ground	PE 	M10 metric threaded stud				

To maintain approvals for cable connections, the Wire Terminals should be UL Listed or Recognised Wire Connectors and Soldering Lugs, fitted to the wire with specified Crimping Tools as indicated by the manufacturer.

* The conductor sizes indicated in the above table are the maximum allowed by UL for each chassis size. The actual conductor used must comply with local wiring regulations.

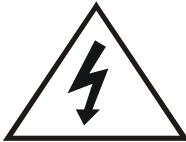
	<p>The owner, installer and user is responsible for the correct installation and use of the SFE3 and must ensure that only qualified personnel install the SFE3 and that the installation, operation and maintenance of the unit complies with the relevant Codes of Practice, Regulations and Statutory Requirements. The Manufacturer or his agent do not assume any liability, expressed or implied, for any consequence resulting from inappropriate, negligent or incorrect installation, application, use or adjustment of the product or circuit design, or from the mismatch of the unit to a motor. To prevent an electrical shock hazard the SFE3 must be connected to a safety earth. The unit is not designed for use in hazardous areas. Use in such an area may invalidate the hazardous area certification.</p>
WARNING	





Supplemental document M-85D1-C, for the SFE3-O soft starter.

For Installation and Operation of the SFE3-O soft starter, the details in the Basic Guide for the SFE3 Soft Starter, M-8588-C apply, except from the following:

1. Basic Ratings

	Connector/ terminal	SFE3-O models	SFE3-O E models	Rated freq.
Rated operational voltage (Ue)	L1,L2,L3	230-460V AC rms	500-690V AC rms	50/60Hz
115V fan supply voltage (models ending -115)	115V	115V AC rms		
230V fan supply voltage (models ending -230)	230V	230V AC rms		
Rated operational current(Ie)	See Semiconductor Fuse types table in Section 2.1			

Index Ratings and Mechanical Outlines

Model name	Ie (A)	AC-53a: X-Tx: F-S	Mechanical Outline – Reference Doc. No
SFE3-O 400 to SFE3-O 600	400A to 600A	AC-53a: 5-4: 60-6 or AC-53a: 3-35 :60-6	M-85D2
SFE3-O 750	750A	AC-53a: 5-4: 60-6 or AC-53a: 3-35 :60-6	M-85D3
SFE3-O 900 to SFE3-O 1100	900A to 1100A	AC-53a: 5-4: 60-6 or AC-53a: 3-35 :60-6	M-85D4
SFE3-O 1200	1200A	AC-53a: 5-4: 60-6 or AC-53a: 3-35 :60-6	M-85D6
SFE3-O 1400 to SFE3-O 1800	1400A to 1800A	AC-53a: 5-4: 60-3 or AC-53a: 3-30 :60-3	M-85D5

2. Safety and installation

Ingress Protection IP00

Suitable for use on a circuit capable of delivering not more than the RMS Symmetrical Amperes indicated in Table 2.1 at maximum rated operational voltage, when protected by Semiconductor Fuse type, Manufactured by Company and Mod. No. indicated in Table 2.1. Fuse rated 700 Vac, Amps as indicated in Table 2.1.

These fuses are for short circuit protection of the semiconductors and must be mounted externally by the user **between** the unit and the mains supply, **not between** the unit and the motor.

Table 2.1 Semiconductor Fuse types

Model Name	Ie (Arms)	Short Circuit Amp RMS (kA)	Fuse details		
			Bussman International Inc. Mod. No.	Siba Mod. No.	Amps
SFE3-O 400	400A	18	170M4466	2066132.630A	630
SFE3-O 500	500A	18	170M5466	2067132.1000A	1000
SFE3-O 600	600A	30	170M5466	2067132.1000A	1000
SFE3-O 750	750A	30	170M6466	2068132.1250A	1250
SFE3-O 900	900A	42	170M6466	2068132.1250A	1250
SFE3-O 1100	1100A	85	170M6467	2068132.1400A	1400
SFE3-O 1200	1200A	85	2 x 170M5466 in parallel per phase	2 x 2067132.1000A in parallel per phase	2000
SFE3-O 1400	1400A	85	2 x 170M6466 in parallel per phase	2 x 2068132.1250A in parallel per phase	2500
SFE3-O 1600	1600A	85	2 x 170M6471 in parallel per phase (See Note #1)	2 x 2068132.2000A in parallel per phase (See Note #1)	4000
SFE3-O 1800	1800A	100	2 x 170M6471 in parallel per phase (See Note #1)	2 x 2068132.2000A in parallel per phase (See Note #1)	4000

Note #1: Limits Rated Operational Voltage to 500VAC.

Mechanical Outline

400 Amp to 600 Amp "O" Range Soft Starters

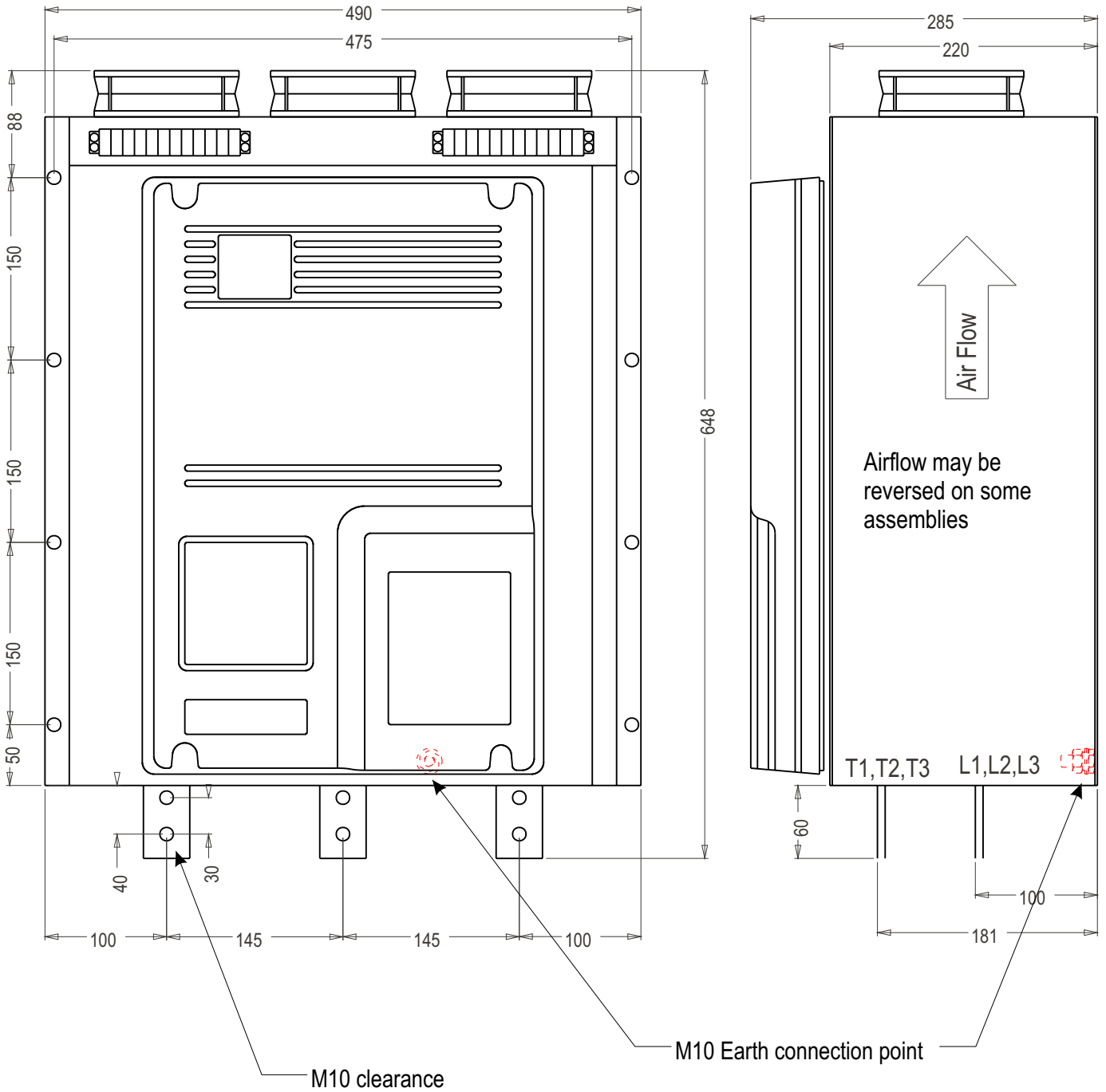

Please Note
 Fans are fixed voltage and must be specified as either 115V or 230V.
ALL DIMENSIONS IN mm.
 Minimum top/bottom clearance - 200mm
 Minimum side clearance - 25mm
 Minimum front clearance - 25mm

NOTE - LIVE HEATSINKS

Mechanical Outline

750 Amp "O" Range Soft Starter

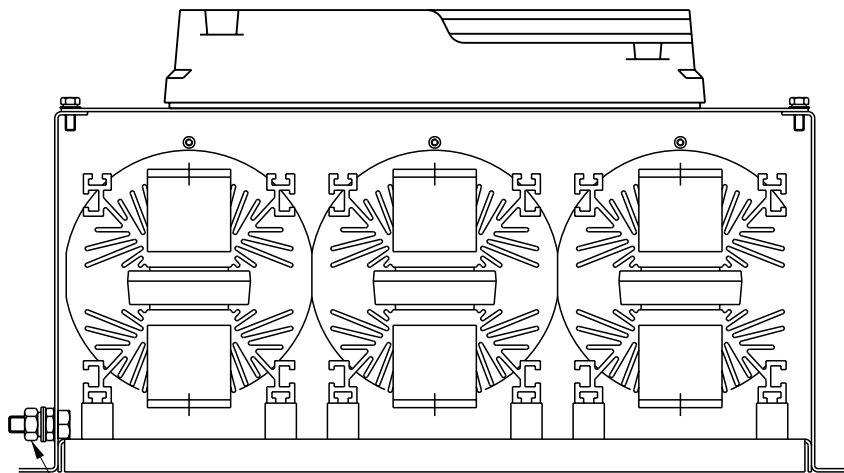
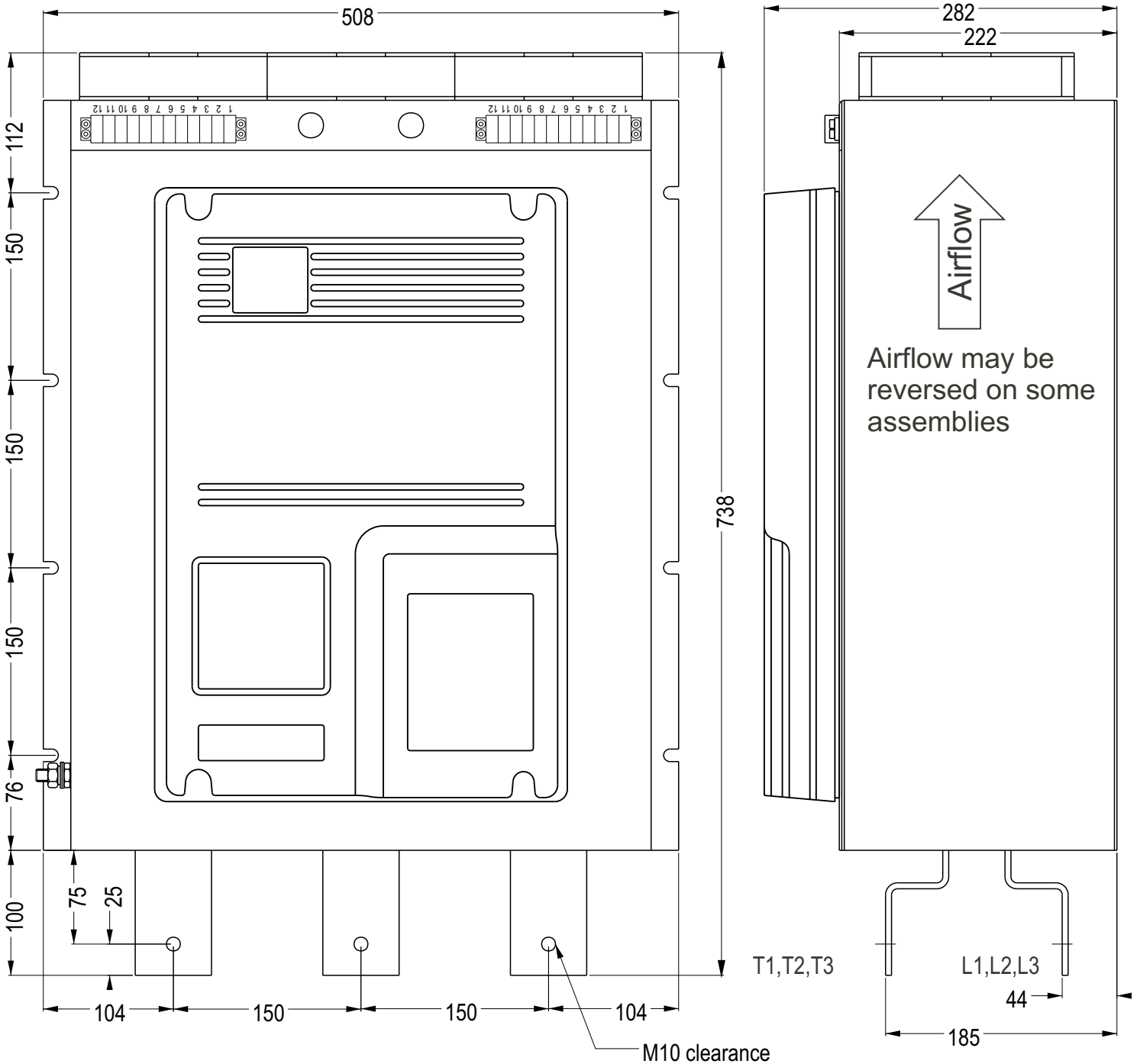

M10 Earth connection point

Please Note
 Fans are fixed voltage and must be specified as either 115V or 230V.
ALL DIMENSIONS IN mm.
 Minimum top/bottom clearance - 200mm
 Minimum side clearance - 25mm
 Minimum front clearance - 25mm

NOTE - LIVE HEATSINKS

Mechanical outline - 900 Amp and 1100 Amp "O" Range Soft Starters

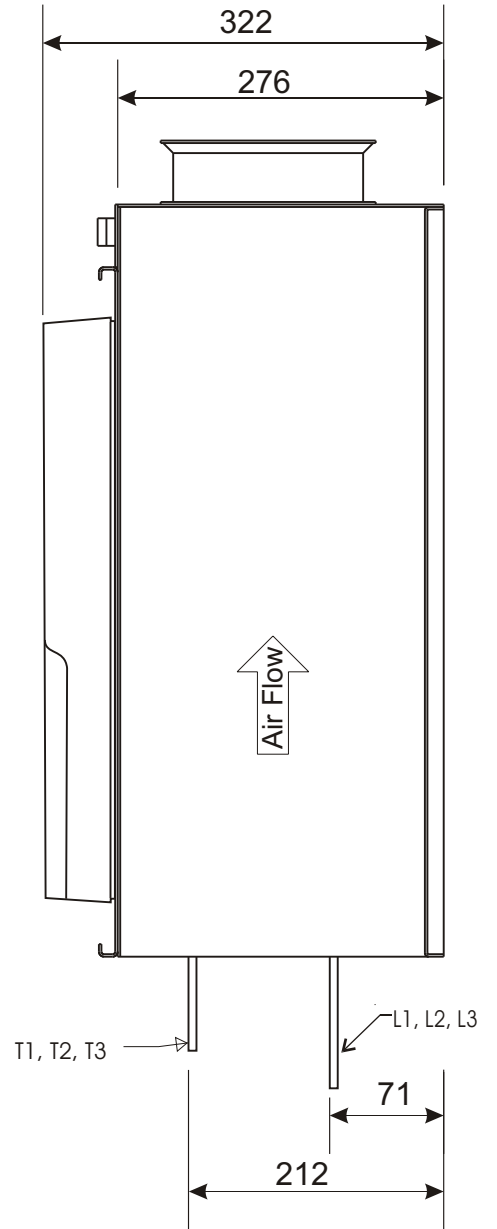
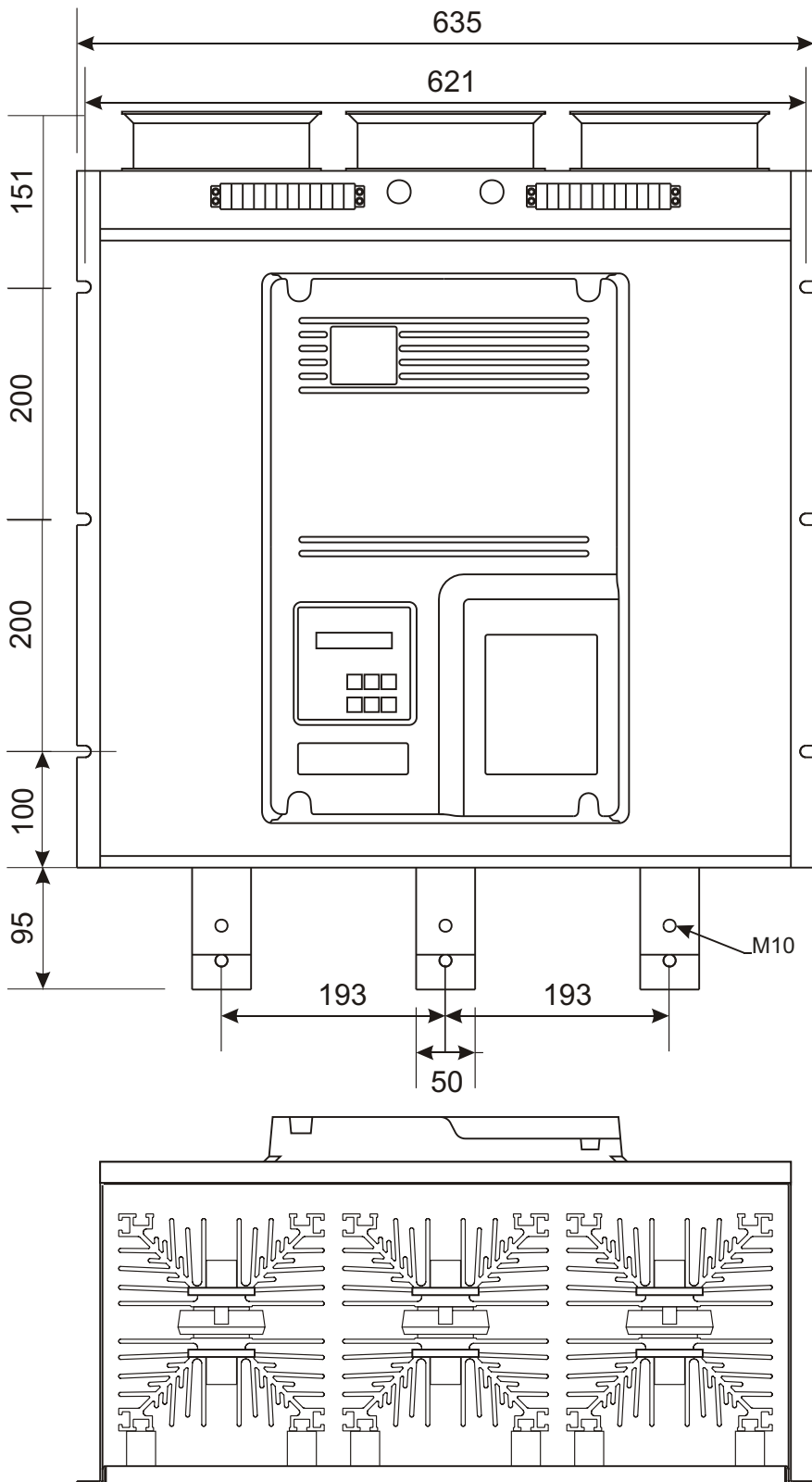

ALL DIMENSIONS IN mm.
 Minimum top/bottom clearance - 200mm
 Minimum side clearance - 25mm
 Minimum front clearance - 25mm

NOTE - LIVE HEATSINKS

Mechanical Outline

1400 Amp to 1800 Amp "O" Range Soft Starters

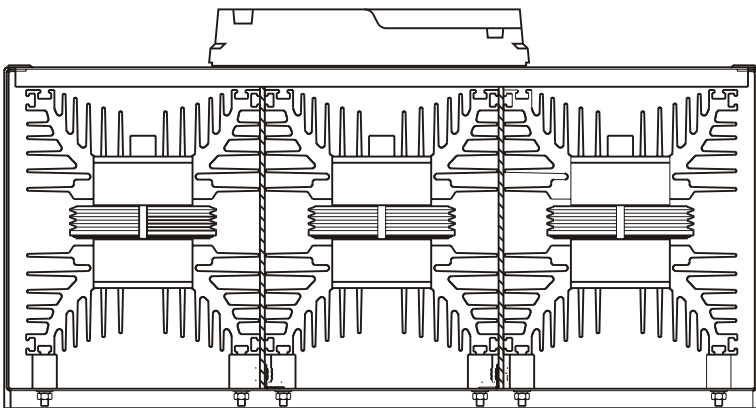
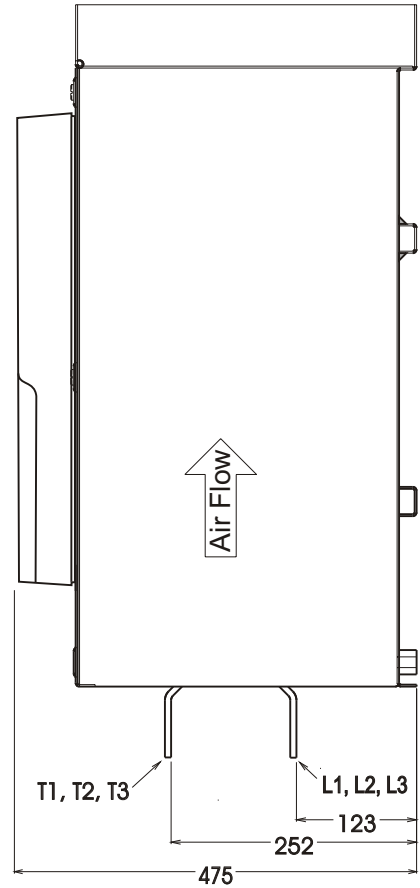
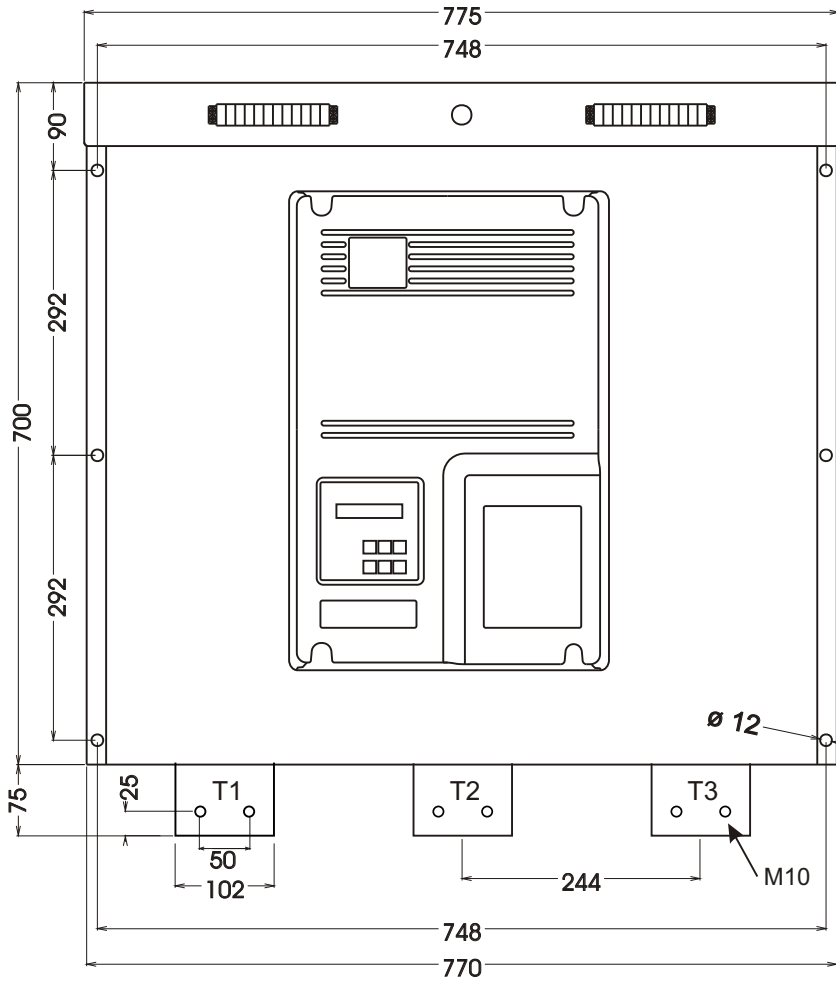

Minimum front clearance 25mm.
 Minimum side clearance 25mm
 Minimum top/bottom clearance 200mm.
 All dimensions in mm.
NOTE - LIVE HEATSINKS

Mechanical Outline 1200 Amp "O" Range Soft Starter

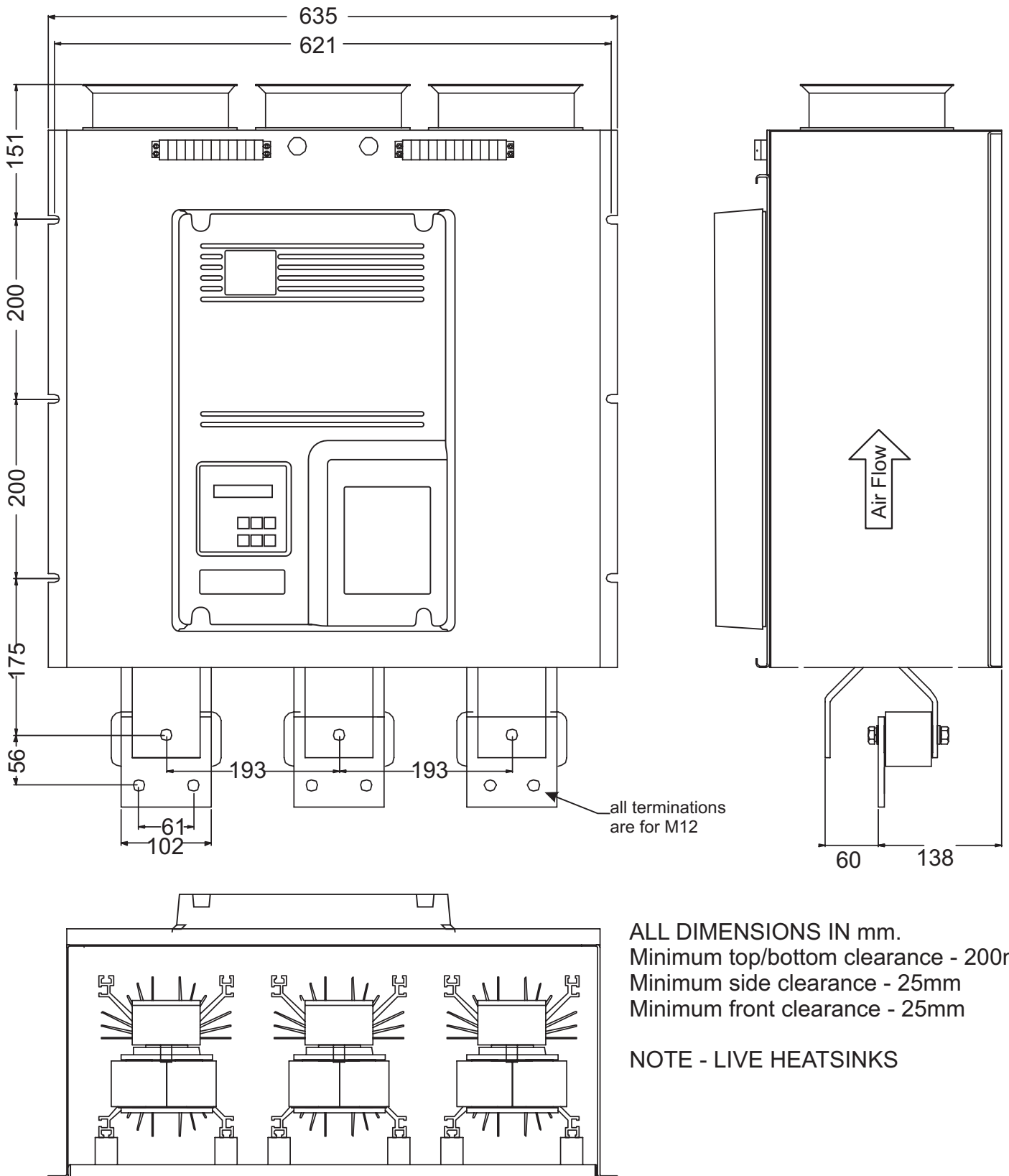

SFE3

Soft Start Motor Controller

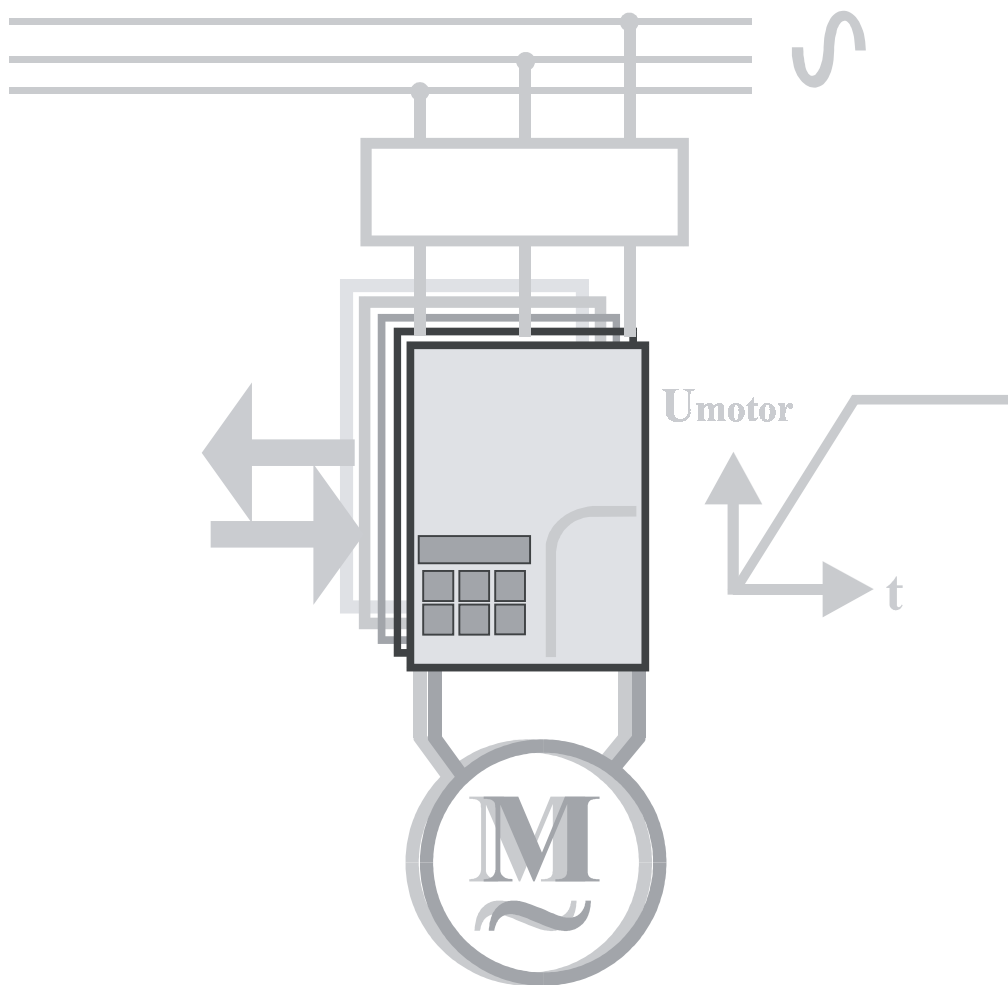

Technical Data for the SFE3 and SFE3plus
Mechanical Installation

FD8412 issue03_C

1	Mechanical Installation	1-4
1.1	Mounting	1-4
1.2	Requirements for an Enclosure	1-4
1.3	Ventilation	1-4
1.4	Storage and De-rating	1-4
1.5	Altitude	1-4
1.6	Assisted Flow	1-5
1.7	Heat Output of units	1-5
1.8	Clearance	1-6
1.9	Mechanical Outline - Chassis Size 1	1-7
1.10	Mechanical Outline - Chassis Size 2	1-8
1.11	Mechanical Outline - Chassis Size 3	1-9
1.12	Extended Gland Plates Option for Chassis size 2	1-10

1 Mechanical Installation

1.1 Mounting

Fix the unit to a flat, vertical surface using the mounting holes (*or slots*) on its base-plate. The mechanical outline diagrams, shown in section 1.5, give the dimensions and mounting hole positions for each model. Ensure that:

- The orientation of the unit has the 'TOP' uppermost .
- The location allows adequate front access.
- You can view the alphanumeric display.

1.2 Requirements for an Enclosure

For a typical industrial environment, an enclosure would provide the following:

- A single location for the unit and its protection/isolation switch-gear.
- The safe termination of cabling and/or bus-bars.
- Means to effect proper air flow through the enclosure.

1.3 Ventilation

The installer must ensure that the enclosure can maintain the operating temperature below 40 °C or with de-rating 60 °C . To ensure that the unit operates within a suitable temperature range, periodically measure the internal temperature of the enclosure. If you situate the unit above equipment that generates a significant amount of heat, reduce the unit full load rating.

1.4 Storage and De-rating

Above 40 °C, de-rate linearly by 2% of Unit FLC/ °C to maximum of 40% at 60 °C.

	Temperature (°C) min.	Temperature (°C) max.
Storage, continuous	- 25	+55
Storage, not exceeding 24 hours	- 25	+70
Operating (without de-rating)	0	+40
Operating (with maximum de-rating)	0	+60

1.5 Altitude

Condition	Maximum height above sea level (m)
Operating(without derating)	1000
Operating(with maximum derating)	2000
De-rating	Above 1000m, derate linearly by 1% Unit FLC per 100m to a maximum of 2000m. For altitudes greater than 2000m, consult your supplier.

1.6 Assisted Flow

An enclosure may need additional fans to maintain the required air temperature immediately surrounding the unit. This is referred to as the Ambient temperature. Use the following formula to determine the fan(s) required. An allowance has been incorporated into the formula so that the figure for “Q” should be the air delivery quoted in the fan suppliers data. Refer to table 1.7 below for the heat produced by the SFE3, and note that the heat figure (Wt) is the total heat produced by everything within the enclosure.

$$Q = \frac{4 \times Wt}{(t_{max} - t_{amb})}$$

Q = required volume of air (cubic metres per hour)

Wt = heat produced by the unit and other heat sources in the enclosure (Watts)

t_{max} = maximum permissible temperature within the enclosure (°C)

t_{amb} = temperature of the air entering the enclosure (°C)

If you prefer to work in CFM, substitute °F for °C.

1.7 Heat Output of units

(At rated operational current, I_e, Unit Full load current (FLC).)

Chassis Size 1		Chassis Size 2		Chassis Size 3	
Model Number	Heat Output (W)	Model Number	Heat Output (W)	Model Number	Heat Output (W)
9	30	174	520	500	1600
16	45	202	610	600	2000
23	60	242	650	750	2500
30	90	300	850	900	3000
44	120	370	970		
59	155				
72	210				
85	220				
105	275				
146	440				

Table 1.7 Approx. heat Output

1.8 Clearance

To maintain adequate ventilation, each model of SFE3 and SFE3plus requires a minimum clearance to adjacent equipment and partitions. These clearances are specified in the table below.

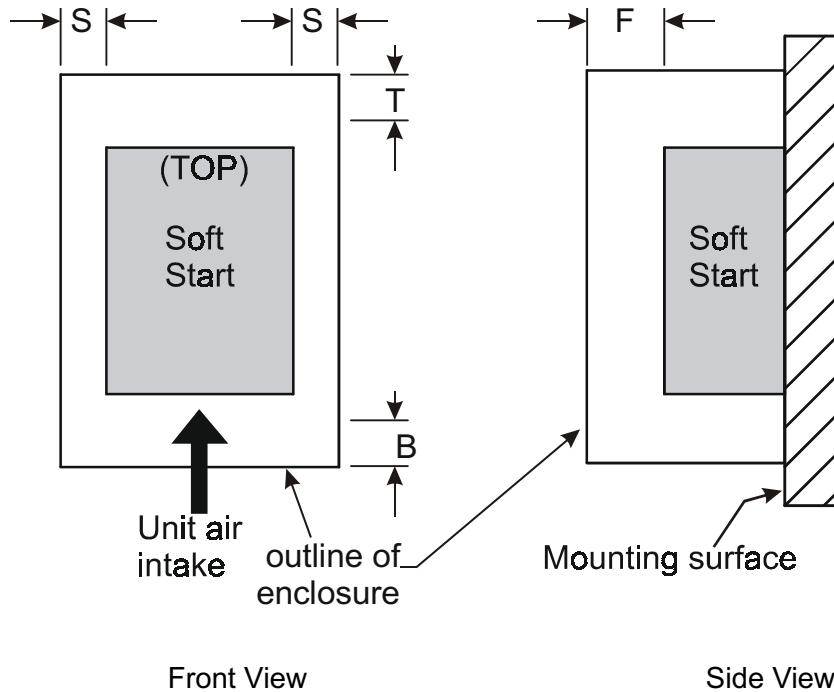

Chassis	Unit cooling Method	Minimum Clearance (mm)			
		Top (T)	Bottom (B)	Side (S)	Front (F)
Size 1 up to & including 23Amp	Natural convection	75	75	15	25
Size 1	Forced-air with built-in fan	75	75	15	25
Size 2		75	75	15	25
Size 3		200	200	25	25

When installing Size 3 units in an enclosure, be sure to allow sufficient space to open the hinged doors. Refer to detailed instructions in section 1.11

1.9 Mechanical Outline - Chassis Size 1

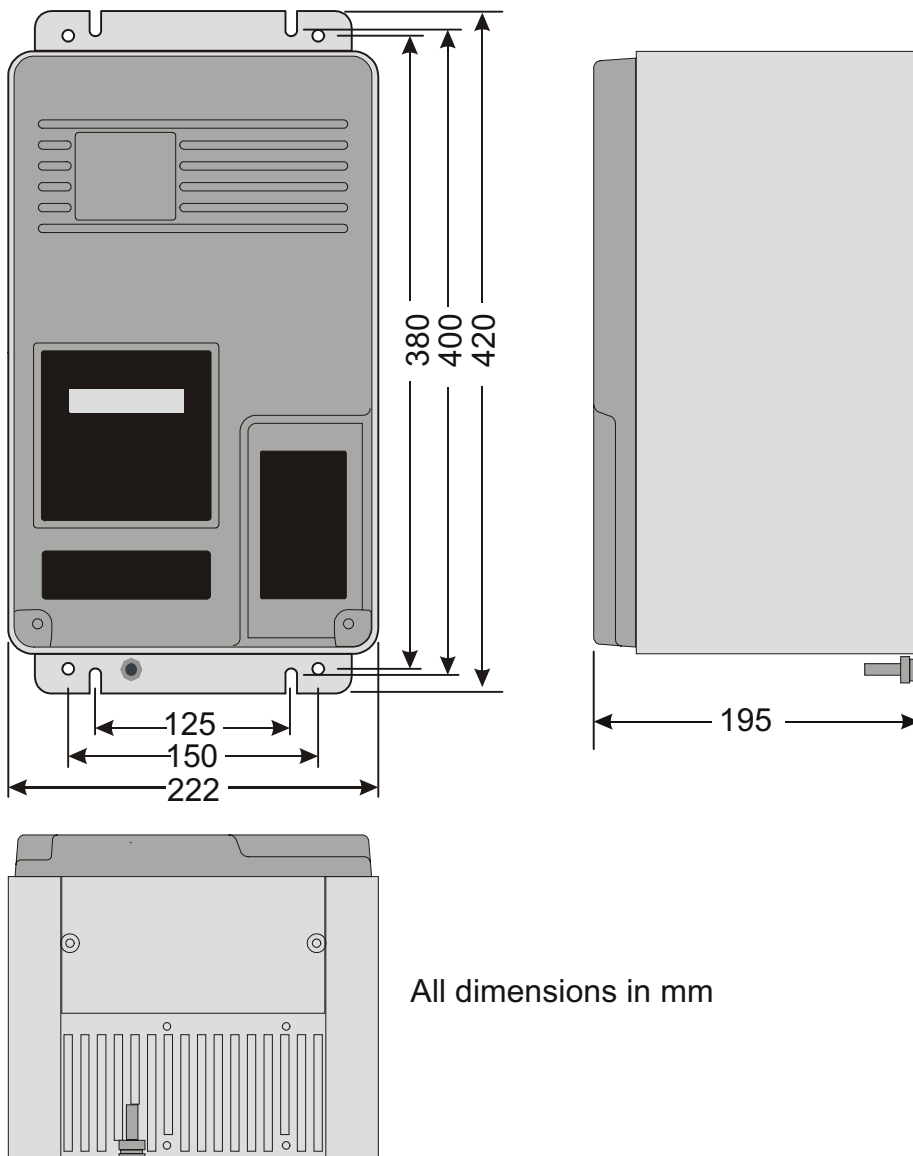

Model Number	Weight (Kg)	Unit Mounting Holes	
		Top	Bottom
SFE3-9	7.3	2 holes; diameter of each hole is suitable for M6 fixings	2 holes; diameter of each hole is suitable for M6 fixings
SFE3-16	7.3		
SFE3-23	7.3		
SFE3-30	7.3		
SFE3-44	7.3		
SFE3-59	8.3		
SFE3-72	8.3		
SFE3-85	8.3		
SFE3-105	8.3		
SFE3-146	8.3		

1.10 Mechanical Outline - Chassis Size 2

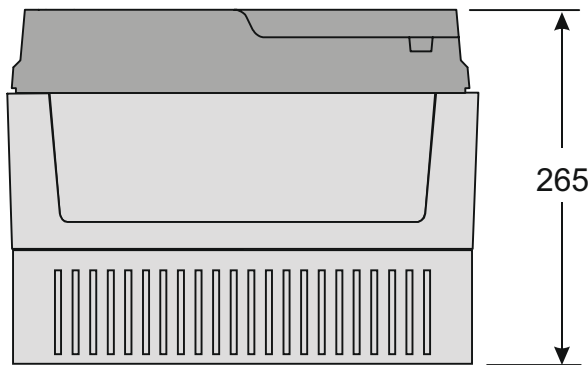
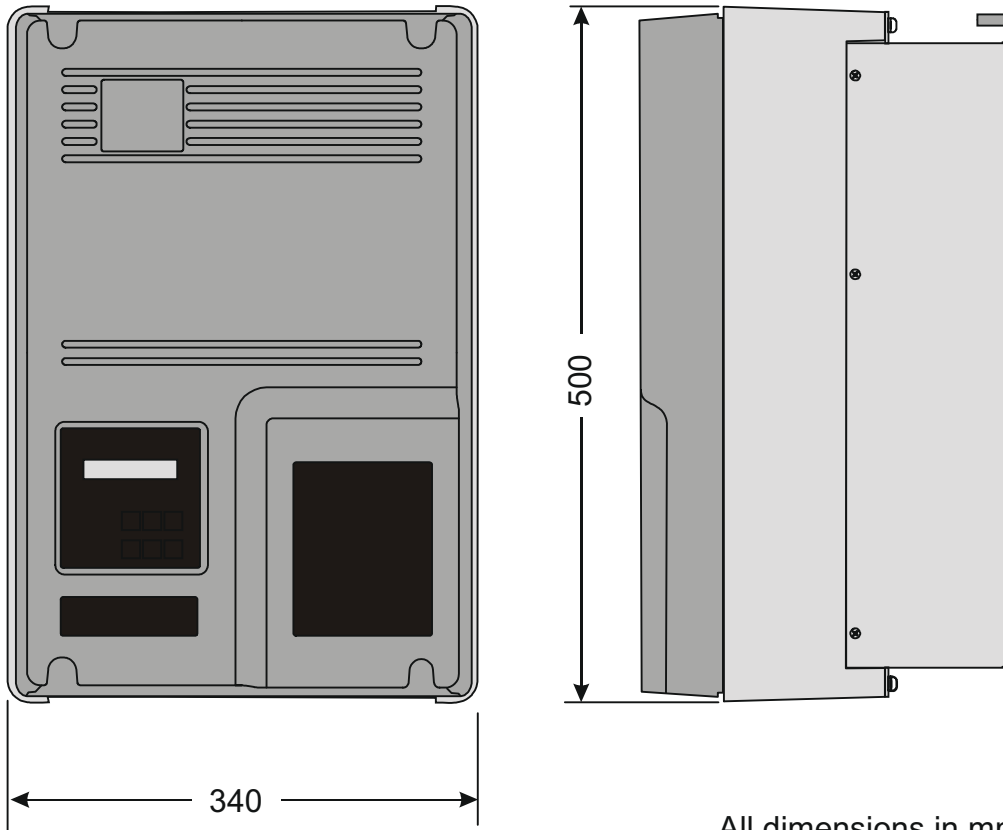

All dimensions in mm
 Mounting Centres
 250 x 500 suitable for
 M6 fixings
 2 "keyholes" at top
 2 open slots at
 the bottom.

Model Number	Weight (Kg)	Unit Mounting Holes	
		Top	Bottom
SFE3-174	15.7	2 keyholes; size of each keyhole is suitable for M6 fixings	2 open slots, each slot is suitable for M6 fixings
SFE3-202	15.7		
SFE3-242	22		
SFE3-300	22		
SFE3-370	22		

1.11 Mechanical Outline - Chassis Size 3

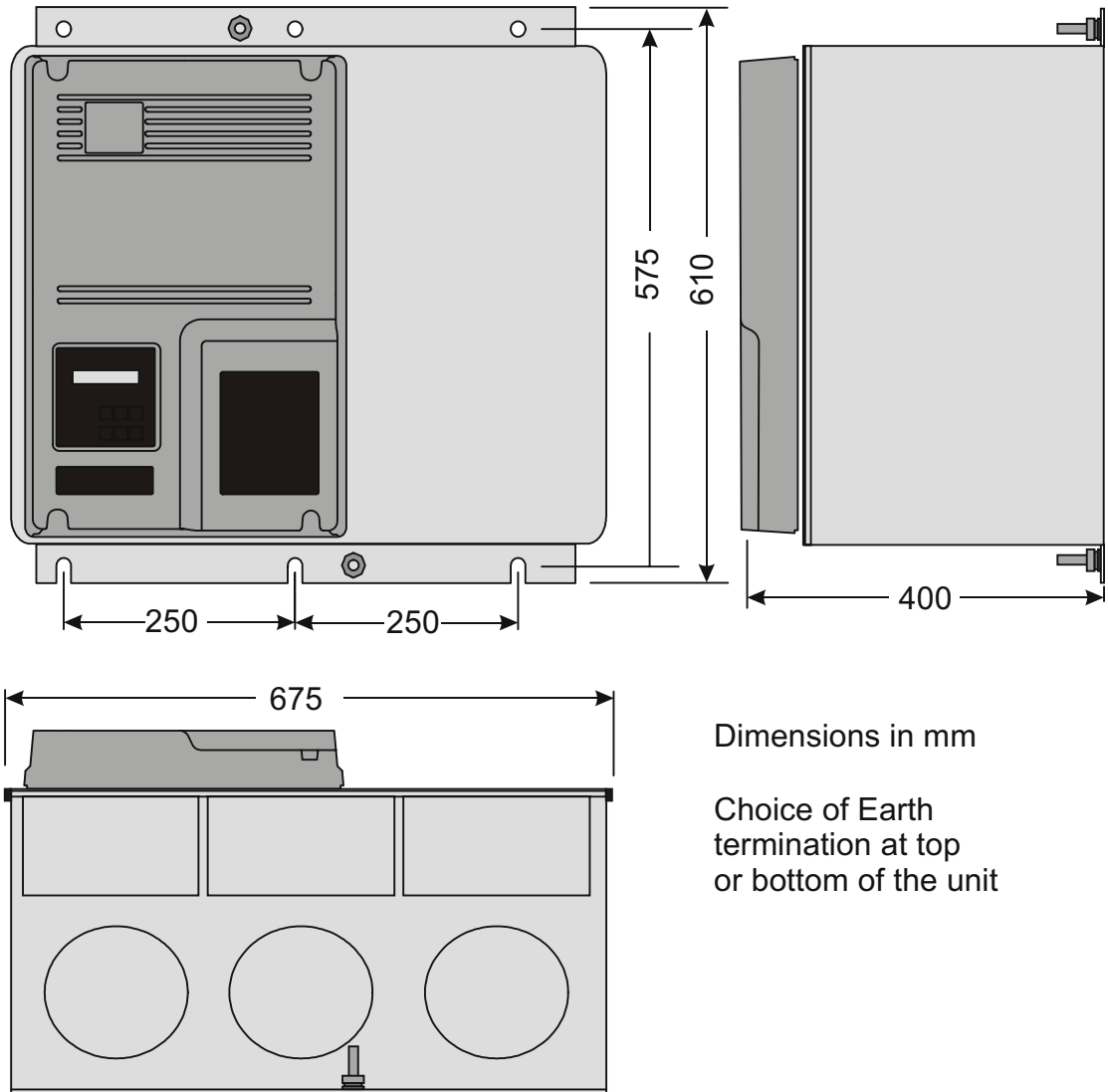

Dimensions in mm

Choice of Earth termination at top or bottom of the unit

Model Number	Weight (Kg)	Baseplate Mounting Holes	
		Top	Bottom
SFE3-500	65	3 holes, diameter of each hole is suitable for M10 fixings	3 open slots, each slot is suitable for M10 fixings
SFE3-600	65		
SFE3-750	72		
SFE3-900	72		

SFE3 and SFE3plus in Chassis Size 3 comply with IP20 specification.

When fitting the unit into a cabinet, allowance must be made for 90° opening of the hinged unit doors. Add 90mm for the left-hand door which has the plastic moulding and the control card, and 30mm for the right hand door i.e. $90 + 675 + 30 = 795\text{mm}$ as an overall cabinet opening.

1.12 Extended Gland Plates Option for Chassis size 2

Extended gland plates are available to give more distance from the cable gland to the terminals when using insulated cables on models of SFE3 in chassis size 2. These are available for the customer to fit in place of the flat gland plates supplied as standard.

One of these assemblies is needed for each end of the unit.

The diagram below illustrates the three main parts of the extended gland plate.

The gland frame (A), side panels (B) (2 for each assembly) and brackets (C) (a mirror image pair for each assembly).

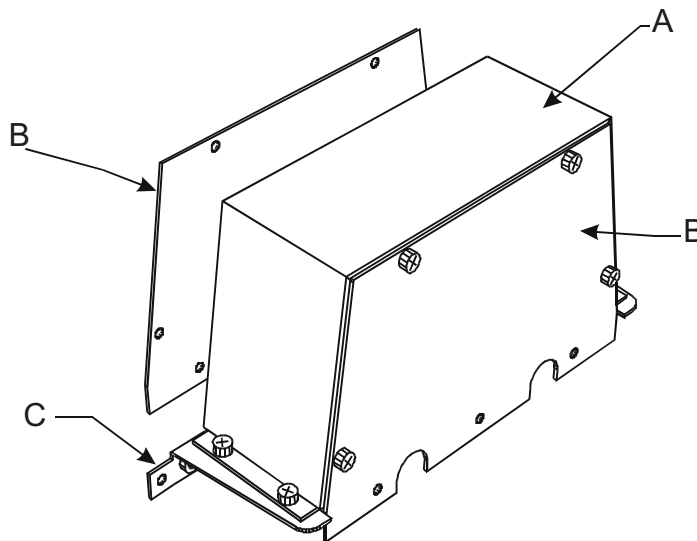

Figure 1.12 Extended Gland Plate

Follow Steps 1 to 9 below for each extended gland plate to be used.

- STEP 1 Determine the cable entry positions for the power and control wiring.
- STEP 2 Fit the cable glands to the extended gland plate.
- STEP 3 Fit one side panel (B) to the gland frame (A) (four M5 x 12mm screws).
- STEP 4 Fit the brackets (C) to the gland frame (A) (four M5 x 12mm screws).
- STEP 5 Remove the existing flat gland plate from the unit, taking note of the positions of washers and earth connections.
- STEP 6 Slide the new assembly into the gland locating slots in the chassis moulding and secure (five M5 x 12mm screws).
- STEP 7 Reconnect the internal earth wires (Green/Yellow insulation) to the captive stud internal to the extended gland plate.
- STEP 8 Remove the two nylon pillars from the standard gland plate and refit on to the extended gland plate. NOTE; bottom right pillar is shorter.
- STEP 9 Fit the remaining side panel (B) to the extended gland plate when the wiring of the unit is complete.

SFE3

Soft Start Motor Controller

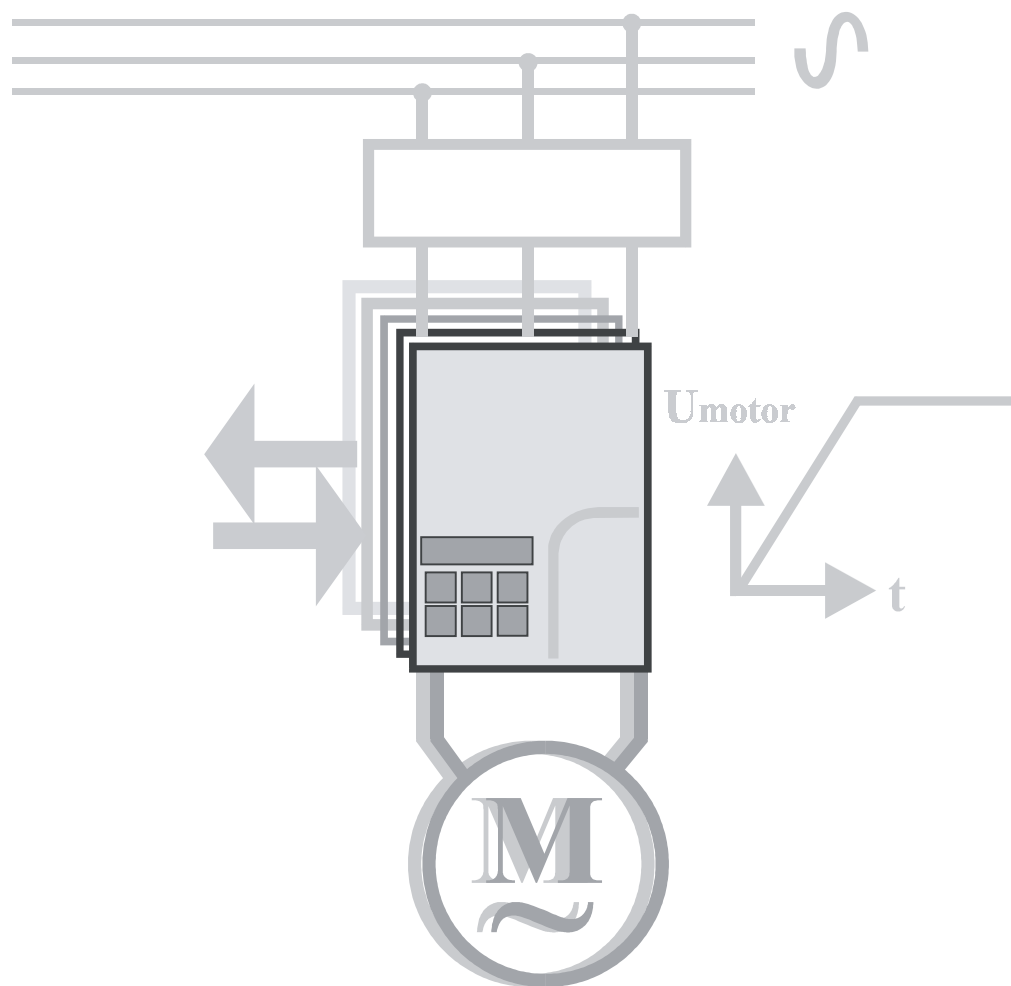

Technical Data for the SFE3 and SFE3plus
Electrical Installation

FD8413 issue03_C

2	Electrical Installation	2-5
2.1	Warnings	2-5
2.1.1	Isolation	2-5
2.1.2	Electrical Control Supply Requirements	2-5
2.1.3	Access	2-5
2.1.4	Fuse Protection	2-5
2.2	Electrical Connections	2-6
2.2.1	Electrical Supplies	2-6
2.2.2	Control, Power and Earth Terminations	2-6
2.3	Standard Wiring Configurations	2-7
2.3.1	Wiring Diagram for In-line Connection of Motors	2-7
2.3.2	Wiring Diagram for In-Delta Connection of Motors	2-8
2.4	Motor Control Circuits	2-9
2.4.1	Bypass Control	2-9
2.4.2	Multiple Motor Starting & Stopping	2-10
2.4.3	External Motor Protection Relay	2-10
2.4.4	Motor Reversing	2-10
2.4.5	Connection of an External Current Transformer	2-10
2.4.6	Wiring diagram for Motor Reversing	2-11
2.5	Electrical Connections	2-12
2.5.1	Chassis Size1 and 2	2-12
2.5.2	Chassis Size 3	2-13
2.5.3	Electronic Control Card	2-14
2.5.4	Auxiliary Function Card	2-15
2.6	Supply Connections	2-16
2.6.1	Electrical Supply	2-16
2.6.2	Motor Connections	2-16
2.6.3	Control Supply	2-16
2.7	Control Card Connections	2-17
2.7.1	Control Inputs	2-17
2.7.2	Auxiliary function Card Inputs - plus models only	2-17
2.7.3	Control Outputs - All models	2-18
2.7.4	Auxiliary function card Outputs - plus models only	2-18
2.9	Typical Motor Powers at rated voltages	2-20
2.9.1	Chassis size1 motor powers	2-20
2.9.2	Chassis size2 motor powers	2-20
2.9.3	Chassis size3 motor powers	2-21
2.9.4	Chassis size4 motor powers	2-21
2.10	Fuse and Current Ratings	2-22
2.10.1	Full-Load, Current Limit and Short-Circuit Protection	2-22
2.10.2	External Fuse Requirements	2-22
2.10.3	Overload Current Profile and Duty Cycle AC-53a	2-23
2.10.4	Overload Current Profile AC-53B	2-24
2.10.5	Overcurrent Trip Graph	2-25

2 Electrical Installation

2.1 Warnings

2.1.1 Isolation

Caution: The SFE3 uses semiconductor devices in the main circuit and is not designed to provide isolation. For this reason isolation means must be installed in the supply circuit in accordance with the appropriate wiring and safety regulations.

2.1.2 Electrical Control Supply Requirements

All Models All electrical connections are made to power input and output terminals, control terminals and an earth stud . Before you apply the control voltage to the control supply terminals, ensure that the selector switch is set to the voltage being used. The diagrams in sections 2.5 show the location of this selector switch. Only make electrical connections to those terminals specified. If you connect to other terminals, then you may cause damage to the internal control circuitry.

2.1.3 Access

Caution: Always replace the cover on the unit after gaining access to the electrical connections.

2.1.4 Fuse Protection

The Mains Supply and the Control Supply each require protection. Although all units have electronic overload protection for the Soft Start, the installer should always fit fuses, for motor protection, **between** the unit and the Mains Supply, **not between** the unit and the motor.

Semiconductor fuses can be supplied as an option for short-circuit protection of the semiconductors. These fuses must be fitted externally to the SFE3 chassis to comply with certain standards. On chassis sizes 2 and 3 there is the facility to fit fuses internally by replacing the fuse links in the power circuit. It is the responsibility of the installer and system designer/specifier to ensure that the required standards or regulations are not affected by so doing.

2.2 Electrical Connections

2.2.1 Electrical Supplies

The unit requires two AC supplies:-

A 3-phase balanced Mains Supply to provide the power for the controlled motor.

A single-phase supply: 115V/230V, 50Hz/60Hz, for the internal control circuitry.

The unit will not operate unless the control supply voltage is within the specified limits.

It is recommended that the control supply is maintained between starts to ensure overload integrity, as the overload will reset on control supply removal.

2.2.2 Control, Power and Earth Terminations

Control terminations

All models - Terminals	Terminal type	Wire type	Cable cross section				Terminal tightening torque
			AWG		mm ²		
			Min.	Max.	Min.	Max.	
X1,X2, S0,S1 11,12,14 21,22,24	Screw clamp terminals	Solid or stranded.	22	14	0.3	2.5	4.4 lb.in. (0.5 Nm.)

Power and Earth Terminations

Size 1: SFE3-9 to SFE3-146 terminals		Terminal type	Conductor type	Cable cross section		Terminal tightening torque
				AWG	mm ²	
Power	L1, L2, L3, T1, T2, T3.	M8 metric threaded studs	Use 75°C copper (CU) conductor only and the wire shall be fitted with close eyelet lug.	1/0	50	106 lb.in. (12 Nm.)
Ground	PE 	M8 metric threaded stud				

Size 2: SFE3-174 to SFE3-370 terminals		Terminal type	Conductor type	Cable cross section		Busbar size (mm)	Terminal tightening torque
				AWG	mm ²		
Power	L1, L2, L3, T1, T2, T3.	M8 metric threaded studs	Use 75°C copper (CU) conductor only and the wire shall be fitted with close eyelet lug or use busbar.	2 x 250MCM	2 x 120	20 x 6	106 lb.in. (12 Nm.)
Ground	PE 	M8 metric threaded stud					

Size 3: SFE3-500 to SFE3-900 terminals		Terminal type	Conductor type	Busbar size (mm)		Terminal tightening torque
Power	L1, L2, L3, T1, T2, T3.	Two off M10 nuts and bolts	Use Busbar	45 x 20	212 lb.in. (24 Nm.)	
Ground	PE 	M10 metric threaded stud		60 x 10 80 x 10		

* The conductor sizes indicated in the above table are the maximum allowed by UL for each chassis size. The actual conductor used must comply with local wiring regulations.

To maintain approvals for cable connections, the Wire Terminals should be UL Listed or Recognised Wire Connectors and Soldering Lugs, fitted to the wire with specified Crimping Tools as indicated by the manufacturer.

2.3 Standard Wiring Configurations

There are two standard wiring configurations for the connection of a motor, a motor controller (Soft Start) and the mains supply:

Configuration 1: In-Line connection for Delta and Star (Wye) Connected Motors

This is the recommended connection and is suitable for most motors.

Configuration 2: In-Delta connection for Delta Connected Motors

If required the SFE3 can be installed within the delta windings.

2.3.1 Wiring Diagram for In-line Connection of Motors

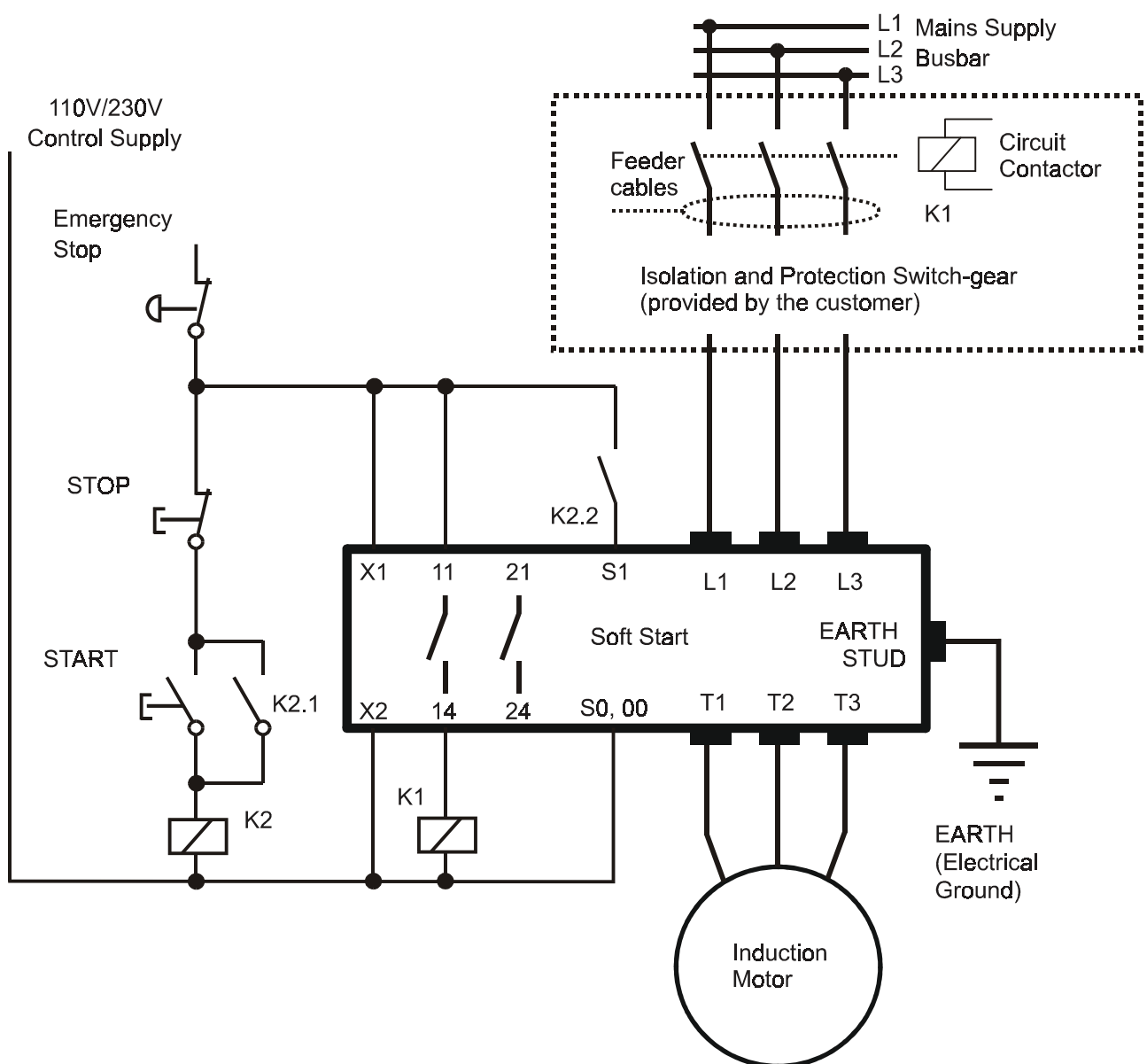

Figure 2.3.1 In-line Connection for Motors

2.3.2 Wiring Diagram for In-Delta Connection of Motors

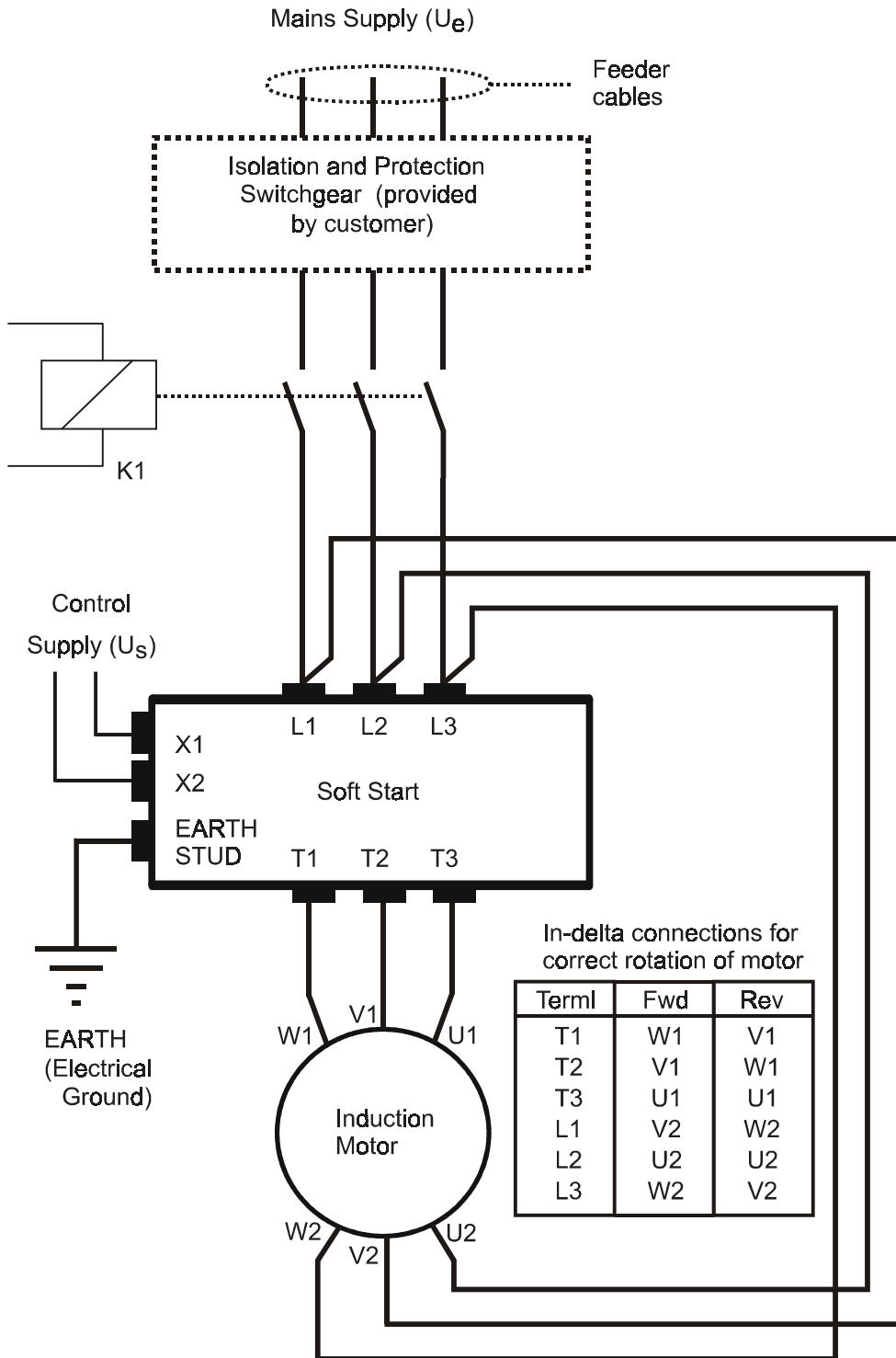

Figure 2.3.2 In-Delta connection for Delta connected induction motors

2.4 Motor Control Circuits

2.4.1 Bypass Control

A separate bypass contactor may be connected in parallel with the SFE3 or SFE3plus. This allows a solid connection of the motor to the mains supply which will eliminate the heating effect associated with thyristor losses. Soft-Starting and Soft-Stopping remain active as normal when the wiring is configured as in Figure 2.4.1.

At the completion of the starting ramp a bypass contactor is closed around the main connections of the Soft Start to remove the thyristors from circuit. The contactor is controlled by a programmable relay set as 'Top of Ramp', which is the default for relay K2. This configuration ensures that bypassing only occurs after the Soft Start has completed the start and the motor terminal voltage is at supply voltage.

The diagrams show typical power and contactor control circuits for bypassing.

The default software configuration will detect the use of a bypass contactor when using this circuit arrangement as "Auto bypass" is set as standard. You can also pre-set the protection mode to either "START+BYPASS" or "PHASE LOSS ONLY" for motor bypassing configurations.

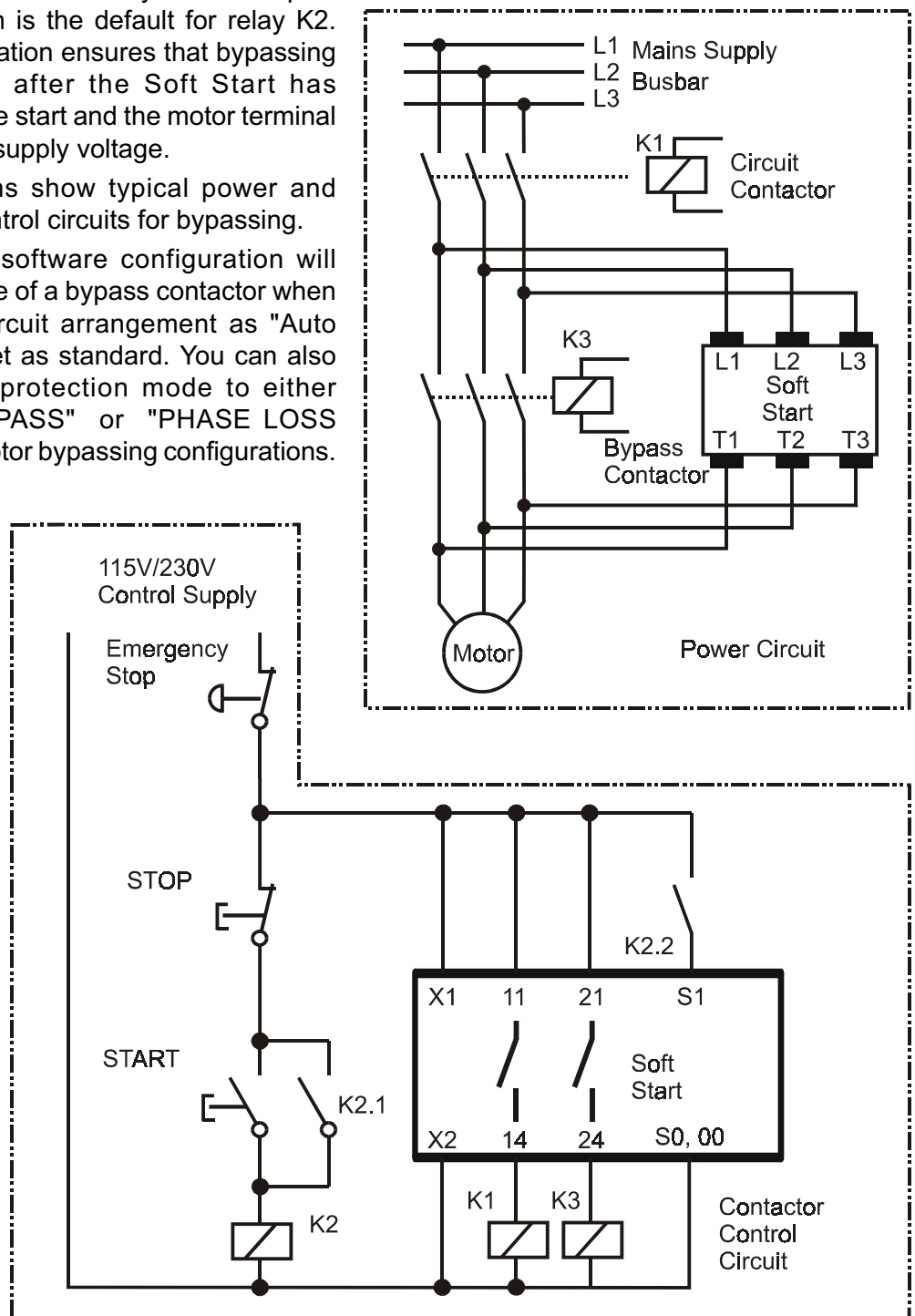

Figure 2.4.1: Power and Contactor Control Circuits for Motor Bypassing

2.4.2 Multiple Motor Starting & Stopping

The SFE3 is capable of starting parallel-connected motors simultaneously provided each motor has similar characteristics and load. For such configurations the unit rating should be at least the sum of the current ratings of all the motors.

Alternatively, the SFE3 can start and stop motors sequentially using bypass contactors under the control of the programmable relay set as a 'Top of Ramp' relay. The dual setting feature allows for the control of motors with different start-up requirements. Details on multiple motor applications can be obtained via your supplier.

2.4.3 External Motor Protection Relay

The rating for a motor protection relay should be as for Direct-on-Line (DOL) starting, and if it is an electronic relay, then the user should confirm its suitability for use with a soft-starter. If the motor load is high-inertia (extended start time) then a longer trip time may be required.

2.4.4 Motor Reversing

The diagram in figure 2.4.6 shows a typical motor reversing circuit using two contactors, K1 and K2, to interchange two phases of the 3-phase supply connections.

For this application the soft stop must be set to zero.

It is also recommended that: -

A period of 150 - 350 ms elapses between the FORWARD and REVERSE commands

If the reversing rate is high, the SFE3 current rating may need to be increased compared to the operational current of the motor. Refer to sections 2.10.3 & 2.10.4 and also the Overcurrent trip curves shown in section 2.10.5.

The current limit and the overload must be set with more consideration to the "reverse" function rather than the "start" as the motor will initially be "plug braked" then be stationary for a moment and finally undergo a normal soft start.

2.4.5 Connection of an External Current Transformer

When using a bypass contactor with the SFE3, it is possible to connect an external current transformer (CT) to the internally mounted electronic control card. This allows more of the control functions of the unit to be used than would normally be available when the unit is bypassed. The current display is also still active. The CT used must be of the same specification as the original item fitted to the unit and the internal CT must be shorted out (preferred option) or removed. For further details, consult your supplier.

2.4.6 Wiring diagram for Motor Reversing

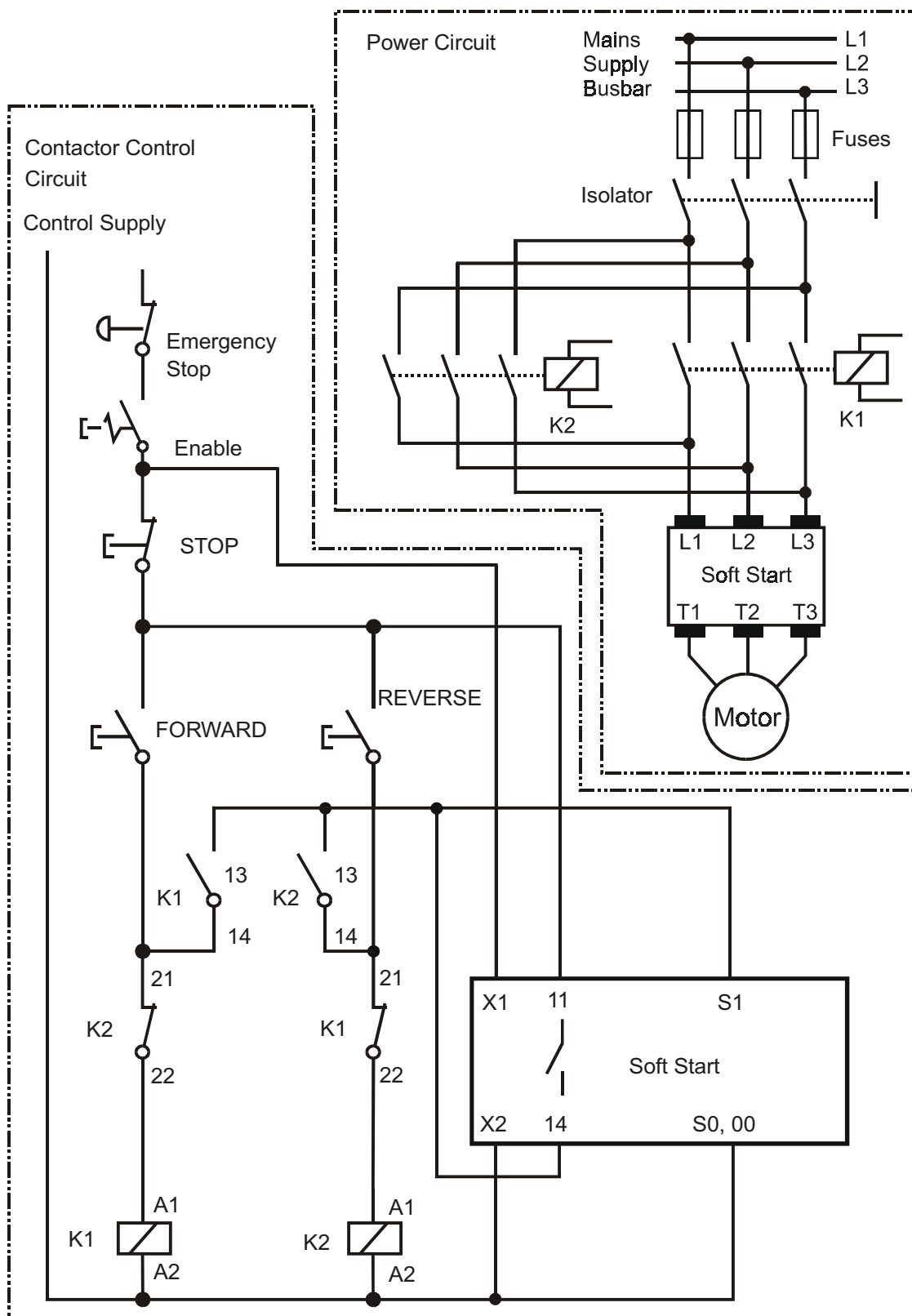

Figure 2.4.6: Typical Power and Contactor Control Circuit for Motor Reversing

2.5 Electrical Connections

SFE3 and SFE3plus

2.5.1 Chassis Size1 and 2

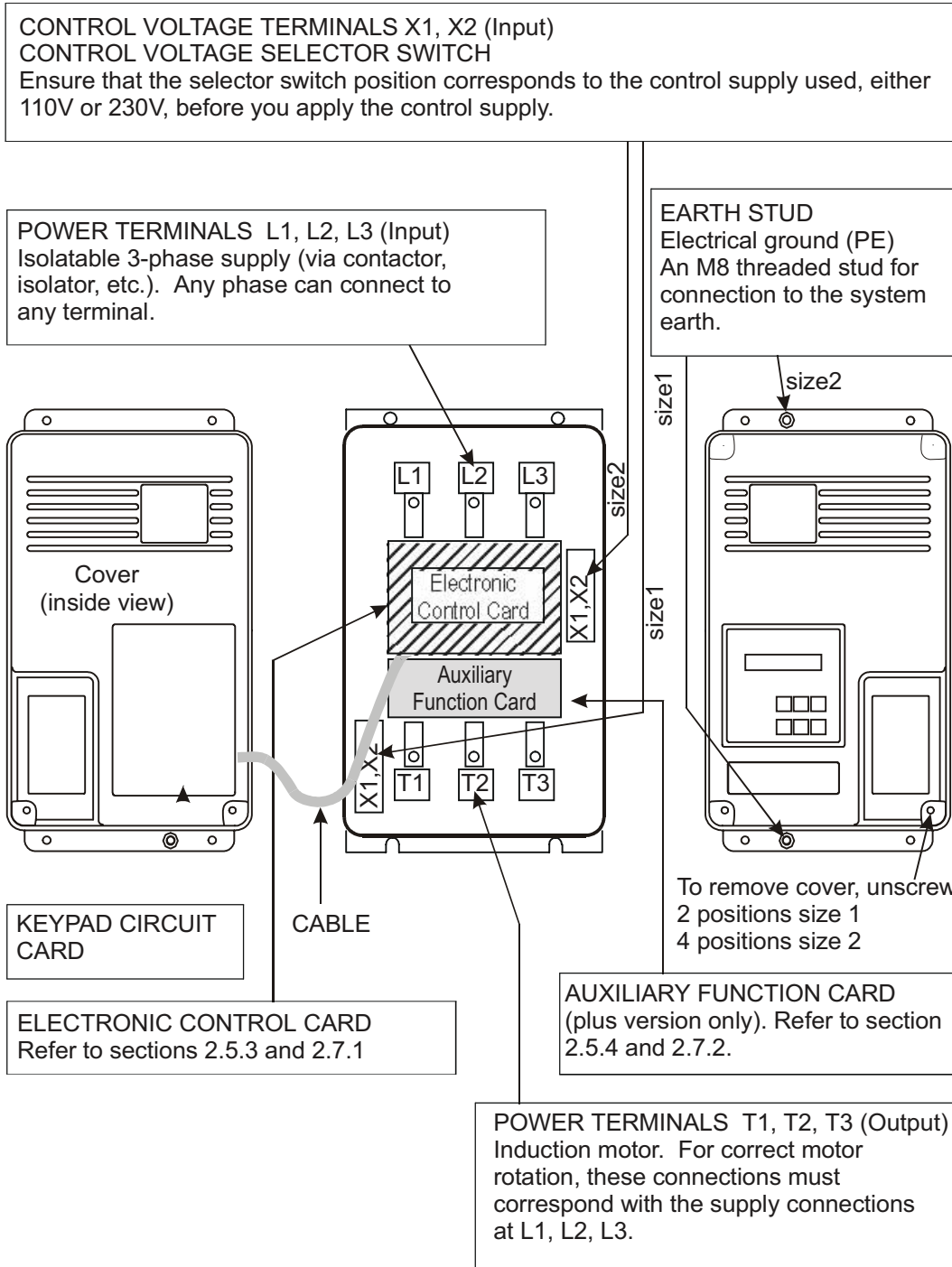

Figure 2.5.1 SFE3 and SFE3plus Chassis Size 1 and 2 Electrical Connections

Take care, when removing and replacing the front cover, not to damage the cable that connects the Keypad and the Electronic control card.

This cable must only be connected or disconnected when the control supply is isolated from the unit, otherwise the circuitry may be damaged.

2.5.2 Chassis Size 3

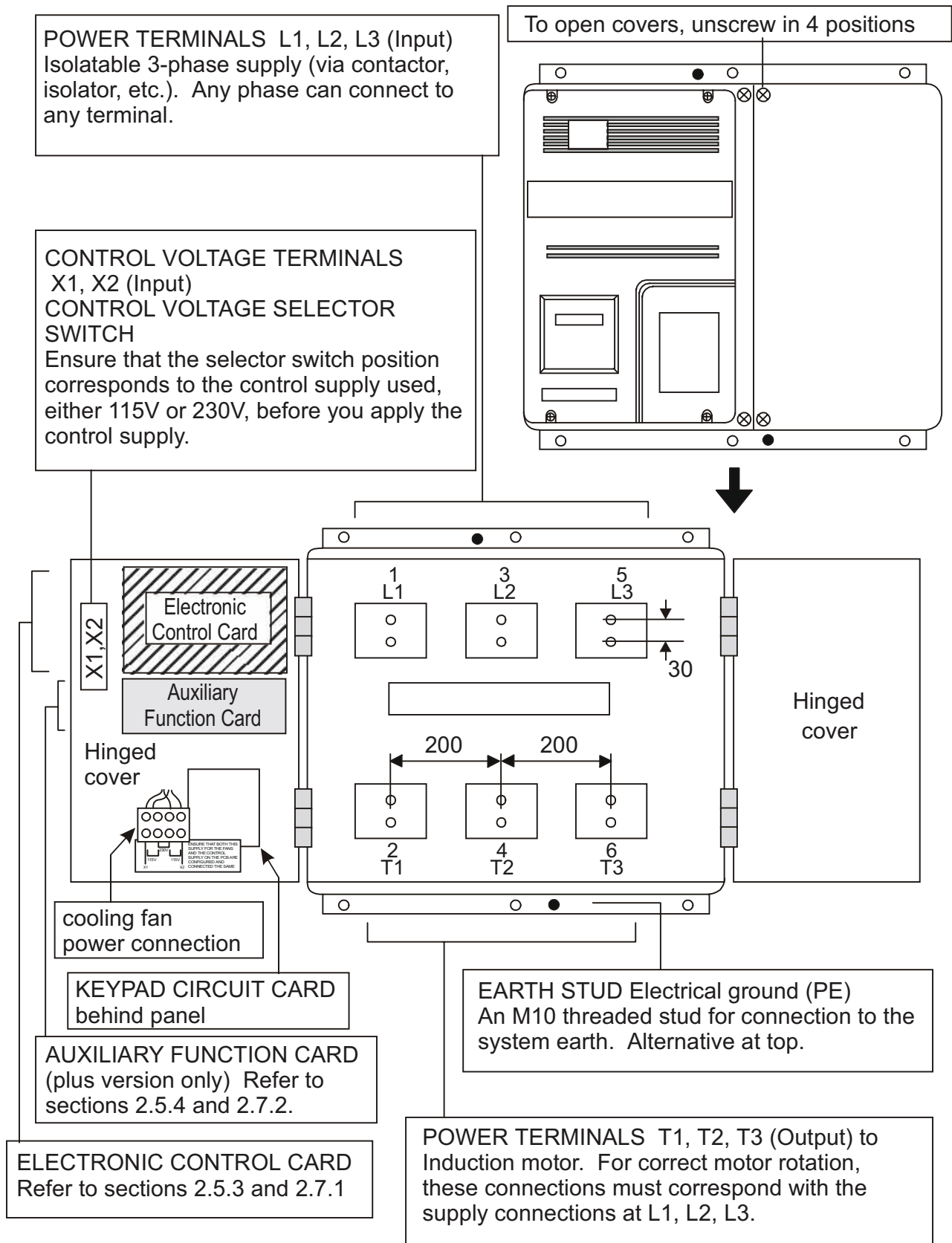

Figure 2.5.2: SFE3 and SFE3plus Chassis Size 3 Electrical Connections

2.5.3 Electronic Control Card

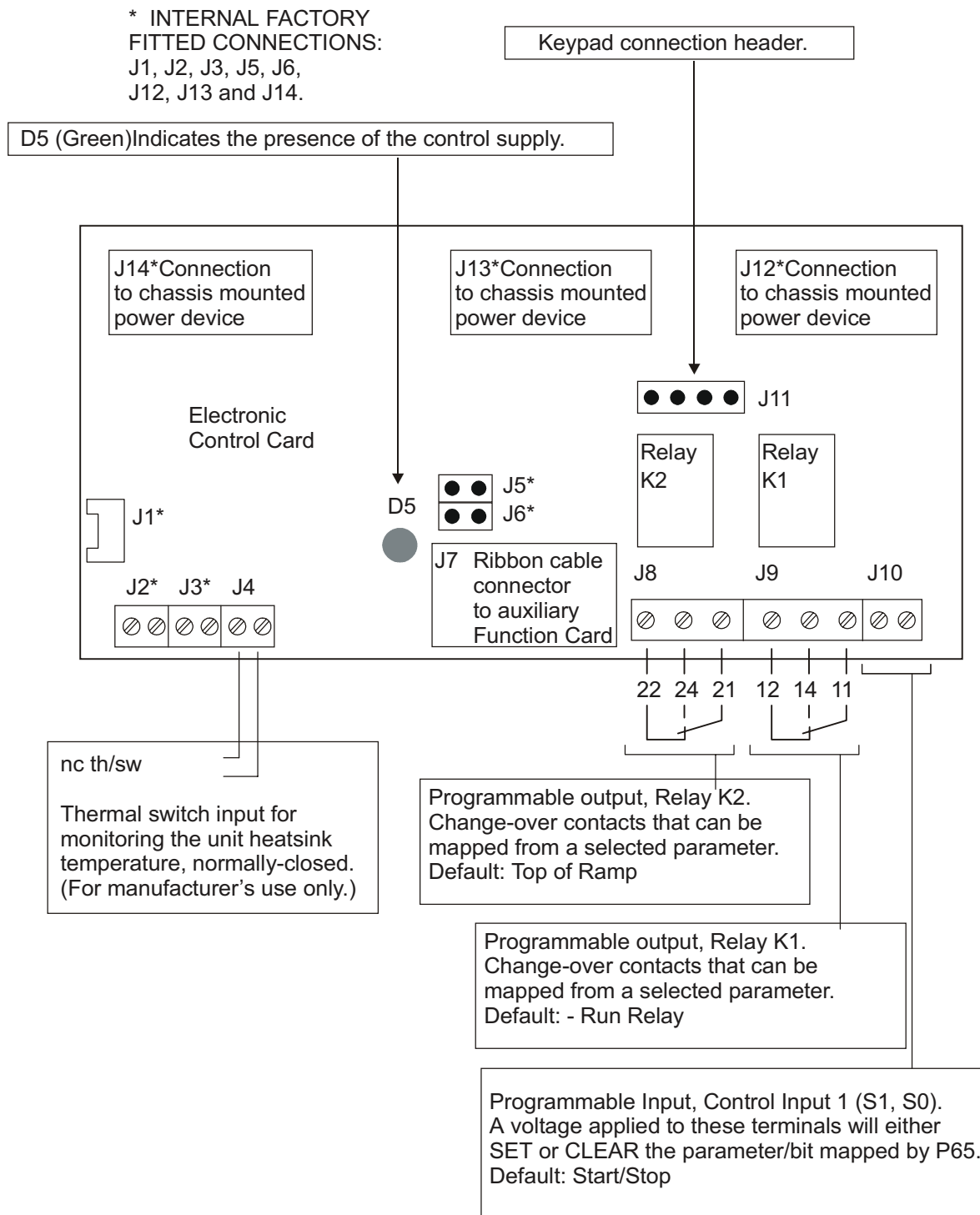
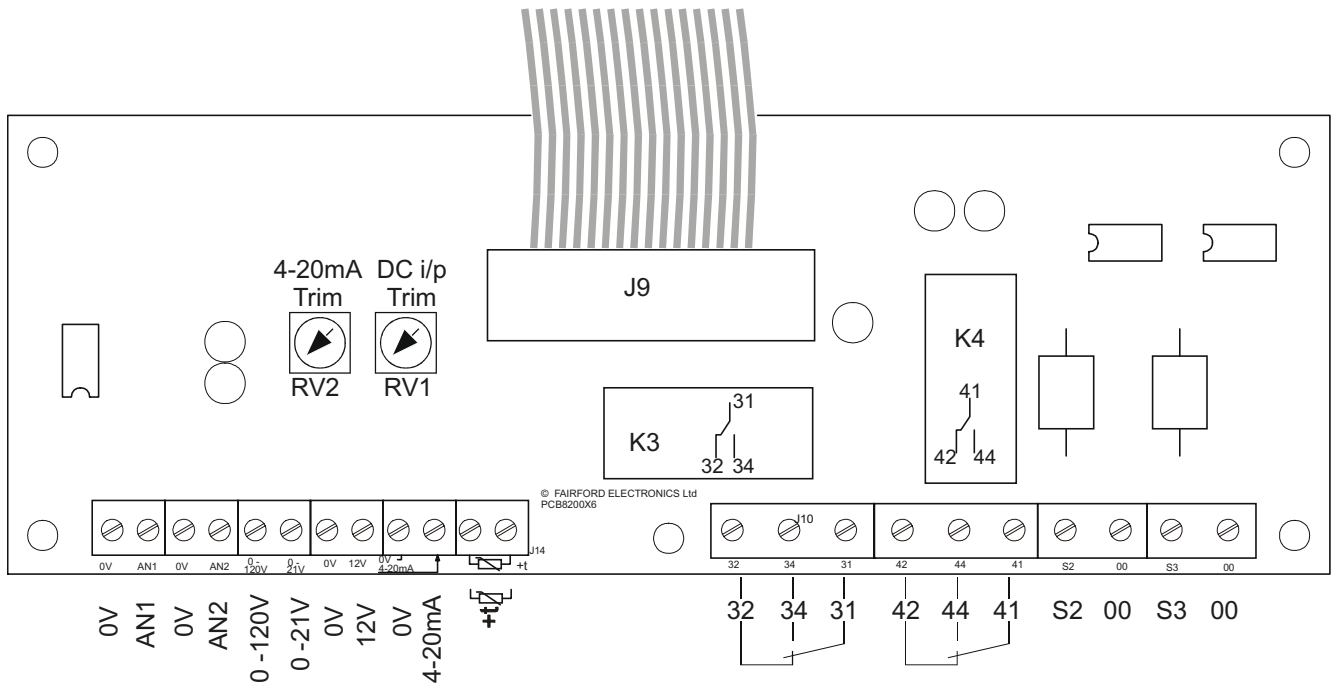

Figure 2.5.3: Electronic Control Card Electrical Connections

2.5.4 Auxiliary Function Card
SFE3plus only



Terminal Markings	Function	Description
0V AN1	Analogue Output 1	A voltage (range 0-10V) represents the analogue value of a selected parameter. <i>(Advanced user facility)</i>
0V AN2	Analogue Output 2	A voltage (range 0-10V) represents the analogue value of a selected parameter. <i>(Advanced user facility)</i>
0-120V	No function	This is an unused terminal
0-21V	DC Input	A 0-21V that is factory pre-set for a 0-10V input range but can be trimmed up by the user to the full 0-21V range. Can be mapped to a selected parameter. <i>(Advanced user facility)</i>
0V	Zero volts	Common 0V terminal for DC input and Voltage Output.
0V 12V	Voltage Output	A voltage source (12V, 100mA max.) for use with either the 4-20mA input or the DC input. <i>(Advanced user facility)</i>
0V 4-20mA	4-20mA Input	Input for an external electronic device with analogue trimming pot. Can be mapped to a selected parameter. <i>(Advanced user facility)</i>
T1 +t T2	Thermistor Input	Two-wire input for a PTC motor thermistor. P42 indicates the relative value.
32 34 31	Programmable Output Relay K3	Relay K3 Default function - Alarm Changeover contacts that can be mapped from a selected parameter. <i>(Advanced user facility)</i>
42 44 41	Programmable Output Relay K4	Default function - Overload Integrator Changeover contacts that can be mapped from a selected parameter. <i>(Advanced user facility)</i>
S2 00	Programmable Input 2	Control Input 2 Can be mapped to a selected parameter. <i>(Advanced user facility)</i>
S3 00	Programmable Input 3	Control Input 3 Can be mapped to a selected parameter. <i>(Advanced user facility)</i>

2.6 Supply Connections

2.6.1 Electrical Supply

Power terminals 1 L1, 3 L2, 5 L3 on all units may be connected to a balanced 3-phase, 3-wire AC supply that is within the limits specified below.

	Nominal Supply Voltage Range	
Rated Operational Voltage (U_e) 230V/460V	230 -15%	460 + 10%
Rated Frequency (Hz)	50/60 +/- 2Hz	

	Nominal Supply Voltage Range	
Rated Operational Voltage (U_e) 400V/575V	400 -15%	575 + 10%
Rated Frequency (Hz)	50/60 +/- 2Hz	

	Nominal Supply Voltage Range	
Rated Operational Voltage (U_e) 500V/690V	500 -15%	690 + 10%
Rated Frequency (Hz)	50/60 +/- 2Hz	

Phase sequence:

The SFE3 will operate with any 3-phase rotation sequence. It is important however, to ensure that the correct connections are made when used with a rotation sensitive load

2.6.2 Motor Connections

The motor connects to terminals **2 T1, 4 T2, 6 T3**. All **SFE3** units will control any standard 3-phase squirrel-cage induction motor capable of operating satisfactorily when connected to the main supply with its normal load coupled.

2.6.3 Control Supply

All units require a separate 2-wire, single-phase supply connected to terminals **X1 and X2**. At the Control Voltage Selector Switch, the user can select either 115V or 230V. The diagrams in section 2.5 show the location of the terminals X1 and X2 for each model of SFE3.

Supply voltage must be in the range 115V (-15%, +10%) or 230V (-15%, +10%).

- Note: 1. *The control supply requires external fuse protection.*
 2. *Ensure that the control Voltage selector switch is set correctly before applying power.*

Chassis size	Current rating	Nominal Power Consumption	115V fuse	230V fuse
Size 1	up to 23A	8VA	125mA	63mA
	30A & 44A	10VA	200mA	100mA
	59A to 146A	12VA	200mA	100mA
Size 2	174A to 370A	18VA	200mA	100mA
Size 3	500A to 900A	control card 8VA separate fan supply 140VA	125mA 2A	63mA 1A

2.7 Control Card Connections

All the control inputs and outputs are on the Electronic Control Card (ELC), mounted within the unit. Diagrams in section 2.5 show the location of the electronic control card.

2.7.1 Control Inputs

Identification	Description
nc th/sw	Thermal switch input (2 terminals). The internal thermal switch connections to monitor the unit heatsink temperature. <i>(For use by the manufacturer only.)</i>
Start/Stop 12/24V DC or 115/230V AC	Programmable Input, Control Input 1. (S1, S0) Application of a voltage between S1 and S0 will either SET (normal logic sense) or CLEAR (inverted logic sense) the parameter mapped to by parameter P65. Removal of this voltage will either CLEAR (normal logic sense) or SET (inverted logic sense) the parameter mapped to by parameter P65 The default setting is P52, Bit 4: Start/Stop, which is active only when the operator selects and enters <code>REMOTE STARTING</code> at the keypad. The application of a voltage, as specified, between these terminals, will initiate a START. The removal of this voltage will initiate a STOP.

2.7.2 Auxiliary function Card Inputs - plus models only

Additional inputs available on the Auxiliary Function Card fitted within the unit.

The Auxiliary Function Card mounts within the unit on the SFE3plus.

The diagrams in section 2.5 show the location of the auxiliary function card.

Identification	Description
0-21V with 0V	Programmable Input, DC Input. The voltage applied between 0-21V and the adjacent 0V return connection (common with 0-12V output), maps to the parameter selected by P47. Can be used for monitoring and selecting set points. Input can also be used for the control of static loads. Default setting, 0: no parameter selected.
S2, 00	Programmable Input, Control Input 2. Operation is the same as Control input 1 (S0, S1 on the main control card) Sets or clears the parameter mapped to by parameter P67 Default setting, None
S3, 00	Programmable Input, Control Input 3. Operation is the same as Control input 1 (S0, S1 on the main control card) Sets or clears the parameter mapped to by parameter P69 Default setting, None
+t	Thermistor Input (2 terminals). For the connection of a standard PTC motor thermistor to BS4999 or IEC 34-11.
4-20mA, 0V	Programmable Input, 4-20mA Input. The signal maps to the parameter selected by P45. Can be used for monitoring and selecting set points. Input can also be used for the control of static loads. Default setting, 0: no parameter selected.

2.7.3 Control Outputs - All models

Identification	Description
12, 14, 11	<p>Programmable Output, Relay K1.</p> <p>A Bit = 1 on the parameter/bit selected by P57 makes Relay K1 ACTIVE (normal logic sense) or INACTIVE (inverted logic sense).</p> <p>Default setting, P52, Bit 5: Main Contactor</p> <p>Relay change-over contacts: Contact rating:- 230VAC, 3A AC11</p> <p>11 - Common. 12 - Normally-closed. 14 - Normally-open</p>
22, 24, 21	<p>Programmable Output, Relay K2.</p> <p>A Bit = 1 on the parameter/bit selected by P59 makes Relay K2 ACTIVE (normal logic sense) or INACTIVE (inverted logic sense).</p> <p>Default setting, P8, Bit 3: Top of Ramp or Full Volts</p> <p>Relay change-over contacts: Contact rating:- 230VAC, 3A AC11</p> <p>21 - Common. 22 - Normally-closed. 24 - Normally-open</p>

2.7.4 Auxiliary function card Outputs - plus models only

Additional outputs available on the Auxiliary Function Card fitted within the unit.

The Auxiliary Function Card is fitted within the unit on the SFE3plus.

The diagrams in section 2.5 show the location of the auxiliary function card.

Identification	Description
0V, AN1	<p>Programmable Output, DAC OUTPUT 1.</p> <p>Analogue output. A signal that represents the analogue value of the parameter mapped from P49.</p> <p>Default setting, P26:- Running Current</p> <p>Voltage range: 0V to 10V. Maximum current: 10mA</p>
0V, AN2	<p>Programmable Output, DAC OUTPUT 2.</p> <p>Analogue output. A signal that represents the analogue value of the parameter mapped from P50.</p> <p>Default setting, P22:- Delay Angle</p> <p>Voltage range: 0 - 10V. Maximum current: 10mA</p>
0V, 12V	<p>A voltage source for use with either the 4-20mA or the 0-21V input.</p> <p>Maximum current output: 100mA</p>
32, 34, 31	<p>Programmable Output, Relay K3.</p> <p>A Bit = 1 on the parameter/bit selected by P61 makes Relay K3 ACTIVE (normal logic sense) or INACTIVE (inverted logic sense).</p> <p>Default setting, P9, Bit 0: Alarm</p> <p>Relay change-over contacts: Contact rating:- 230VAC, 3A AC11</p> <p>31 - Common. 32 - Normally-closed. 34 - Normally-open</p>
42, 44, 41	<p>Programmable Output, Relay K4.</p> <p>A Bit = 1 on the parameter/bit selected by P63 makes Relay K4 ACTIVE (normal logic sense) or INACTIVE (inverted logic sense).</p> <p>Default setting, P9, Bit 1: Overload Integrating</p> <p>Relay change-over contacts: Contact rating:- 230VAC, 3A AC11</p> <p>41 - Common. 42 - Normally-closed. 44 - Normally-open.</p>

2.9 Typical Motor Powers at rated voltages

The Amps values for the soft starter are the maximum continuous current for the model.

2.9.1 Chassis size1 motor powers

Model	Amps	208 Volts		230 Volts		400 Volts		460 Volts		575 Volts G and E models only		690 Volts E models only	
		kW	HP	kW	HP	kW	HP	kW	HP	kW	HP	kW	HP
9	9	1.5	2	2.2	3	4	5.5	4	5.5	5.5	7.5	7.5	10
16	16	2.2	3	3.7	5	7.5	10	7.5	10	9	12	15	20
23	23	3.75	5	6.3	8.5	11	15	11	15	15	20	22	30
30	30	5.5	7.5	7.5	10	15	20	15	20	18.5	25	30	40
44	44	7.5	10	11	15	22	30	22	30	30	40	37	50
59	59	11	15	16	22	30	40	32	42	37	50	55	75
72	72	15	21	20	27	37	50	40	54	45	60	60	80
85	85	18.5	25	22	30	45	60	45	60	55	75	75	100
105	105	22	30	30	40	55	75	55	75	75	100	90	120
146	146	37	50	45	60	75	100	80	106	110	150	132	175

2.9.2 Chassis size2 motor powers

Model	Amps	208 Volts		230 Volts		400 Volts		460 Volts		575 Volts G and E models only		690 Volts E models only	
		kW	HP	kW	HP	kW	HP	kW	HP	kW	HP	kW	HP
174	174	45	60	55	75	90	120	110	150	132	175	160	220
202	202	45	60	63	85	110	150	132	175	150	200	200	270
242	242	55	75	75	100	132	175	150	200	185	250	220	300
300	300	75	100	90	120	160	220	185	250	220	300	250	350
370	370	90	125	110	150	200	270	220	300	250	350	355	470

2.9.3 Chassis size3 motor powers

Model	Amps	208 Volts		230 Volts		400 Volts		460 Volts		575 Volts G and E models only		690 Volts E models only	
		kW	HP	kW	HP	kW	HP	kW	HP	kW	HP	kW	HP
500	500	110	150	160	220	250	350	300	400	375	500	500	670
600	600	150	200	185	250	320	400	375	500	450	600	560	750
750	750	210	280	250	350	400	540	450	600	560	750	710	940
900	900	255	340	300	400	500	670	560	750	670	900	900	1200

2.9.4 Chassis size4 motor powers

Model	Amps	208 Volts		230 Volts		400 Volts		460 Volts		575 Volts G and E models only		690 Volts E models only	
		kW	HP	kW	HP	kW	HP	kW	HP	kW	HP	kW	HP
1100	1100	312	415	340	455	615	820	685	915	855	1140	1100	1465
1200	1200	340	455	375	500	670	895	750	1000	935	1250	1200	1600
1400	1400	395	530	435	580	780	1045	875	1165	1090	1455	1400	1865
1600	1600	450	605	500	665	895	1190	1000	1330	1250	1665	1600	2130

This chassis size is always built to order and can therefore be made for a specific duty other than the standard ratings. Please contact your supplier for details regarding this Chassis size.

The motor ratings are the nearest values for the output powers of standard squirrel-cage motors below the unit current rating of the SFE3.

The currents quoted are for 3-phase, 4-pole motors operating on 50/60Hz supplies. Actual currents of motors may vary by $\pm 10\%$ depending on size and manufacturer. Motors of lower speeds generally draw higher currents for the same rated output. Typically +10% for 6-pole or +20% for 8-pole compared to 4 pole motors.

Motor ratings are in kiloWatts (kW) as defined by the IEC or Horsepower (HP) as defined by the American "National Electrical Code" and are, where possible, normal motor sizes.

2.10 Fuse and Current Ratings

2.10.1 Full-Load, Current Limit and Short-Circuit Protection

Model Name	I _e (Arms)	Short Circuit Amp RMS (kA)	UL Recognized JFHR2 Fuses		
			Bussman International Inc. Mod. No.	Ferraz Mod. No. 6.6 URD followed by	Amps
SFE3-9	9A	5	170M3110	30 D08A 0063	63
SFE3-16	16A	5	170M3110	30 D08A 0063	63
SFE3-23	23A	5	170M3112	30 D08A 0100	100
SFE3-30	30A	5	170M3112	30 D08A 0100	100
SFE3-44	44A	5	170M3114	30 D08A 0160	160
SFE3-59	59A	5	170M3115	30 D08A 0200	200
SFE3-72	72A	10	170M3116	30 D08A 0250	250
SFE3-85	85A	10	170M3116	30 D08A 0250	250
SFE3-105	105A	10	170M3119	30 D08A 0400	400
SFE3-146	146A	10	170M3119	30 D08A 0400	400
SFE3-174	174A	10	170M3121	30 D08A 0500	500
SFE3-202	202A	10	170M3121	30 D08A 0500	500
SFE3-242	242A	10	170M4114	31 D08A 0500	500
SFE3-300	300A	18	170M4114	31 D08A 0500	500
SFE3-370	370A	18	170M4116	31 D08A 0630	630
SFE3-500	500A	18	170M6113	33 D08A 0900	900
SFE3-600	600A	30	170M6113	33 D08A 0900	900
SFE3-750	750A	30	170M6116	33 D08A 1250	1250
SFE3-900	900A	42	170M6116	33 D08A 1250	1250

These fuses are for short circuit protection of the semiconductors and must be mounted externally by the user between the unit and the mains supply.

UL requires Recognized special purpose fuses (JFHR2), for the protection of semi-conductor devices, rated 700 Vac, as indicated in Table 2.10.1, be used to obtain the short circuit ratings required by UL.

Suitable for use on a circuit capable of delivering not more than the RMS Symmetrical Amperes indicated in Table 2.10.1 at maximum rated operational voltage, when protected by Semiconductor Fuse type, Manufactured by Company and Mod. No. indicated in Table 2.10.1 Fuse rated 700 Vac, Amps as indicated in Table 2.10.1.

It is the responsibility of the installer and system designer/specifier to ensure that the required standards or regulations are not affected by so doing.

2.10.2 External Fuse Requirements

The rating of HRC fuses for motor protection needs to be carefully analysed when using a Soft Starter due to the longer start times which are involved. When high inertia loads (e.g. fans) are being started, special consideration should be given to fuse ratings due to the extended ramping times. Most fuse manufacturers have an “extended start” or “dual element” range of fuses intended for this type of application.

For semiconductor protection fusing, refer to the table in section 2.10.1 above.

2.10.3 Overload Current Profile and Duty Cycle AC-53a

IEC 60947-4-2 Motor Utilisation Category: AC-53a (not operating in bypass mode)

Model Numbers	AC-53a overload current profiles applicable to specified models.			
	Overload Current (X, multiple of I _e)	Duration of Overload (T _x , seconds)	Ratio of On-load period to total load (F, %)	Number of operating cycles per hour (S)
9 16 23 30 44 59 72 85	—	—	—	—
	3	35	99	10
	—	—	—	—
	5	4	99	10
105 146 174 202	—	—	—	—
	3	35	99	10
	4	6	99	10
	—	—	—	—
242 300 370 500 600 750 900	—	—	—	—
	3	35	60	3
	4	6	60	3
	—	—	—	—

To calculate times for a lower value of current, divide the square of the next highest given current multiplied by its given time by the square of the required current.

For example, to find the time, T_x, for X=2.5 x I_e, then T_x = (32 x 35)/(2.5²) = 50 seconds.

EXAMPLE IEC RATING INDEX

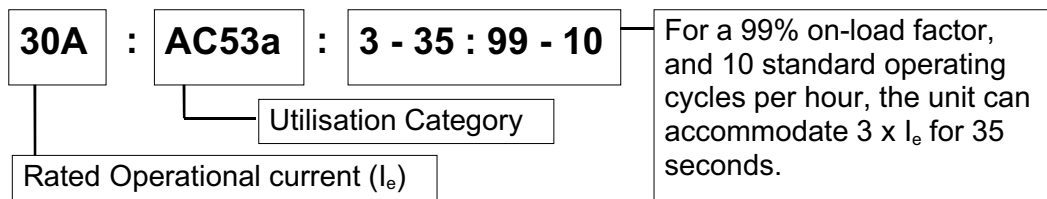

2.10.4 Overload Current Profile AC-53B

IEC 947-4-2 Motor Utilisation Category: AC-53b (operating in bypass mode)

Model Numbers	AC-53b overload current profiles applicable to specified models.		
	Overload Current (X, multiple of I_e)	Duration of Overload (T_x , seconds)	Unit Off Time (OFF-time, seconds)
9	—	—	—
16	—	—	—
23	—	—	—
30	3	35	120
44	—	—	—
59	—	—	—
72	5	4	120
85	—	—	—
105	—	—	—
146	3	35	120
174	4	6	120
202	—	—	—
242	—	—	—
300	—	—	—
370	3	35	360
500	4	6	360
600	—	—	—
750	—	—	—
900	—	—	—

EXAMPLE IEC RATING INDEX

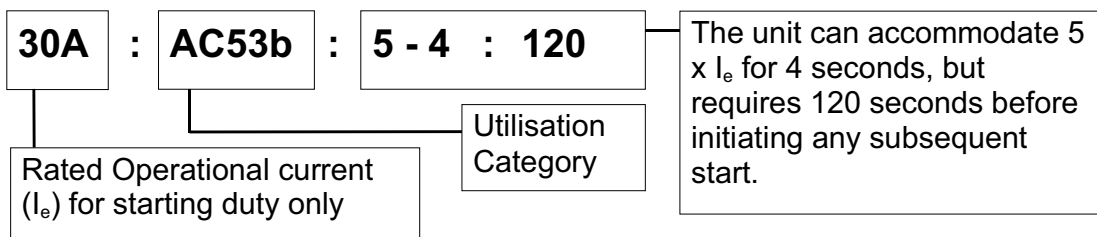

2.10.5 Overcurrent Trip Graph

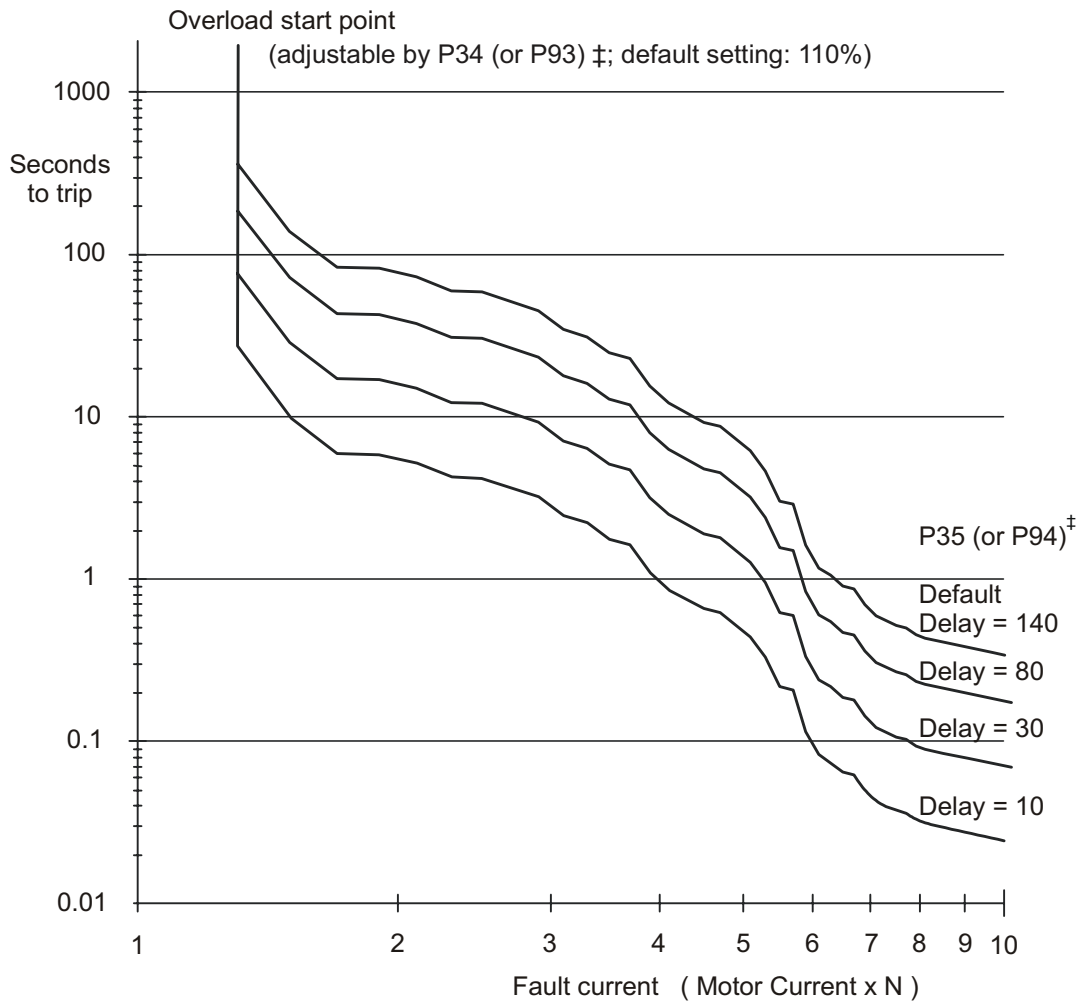

‡ Parameter selected through either the primary or secondary group of value parameters

'Current limit', 'Overload level' and 'Overload delay' settings may be adjusted to limit overload currents in accordance with the trip curves shown here.

For motors with FLC's **lower** than the rated current of the SFE3 the 'Overload level' may be adjusted using the following formula:

$$\text{Overload level} = \text{Motor FLC} \times 1.1 \text{ (A)}$$

Notes:

- 1 The overload monitors one of the phases only and the 'Current Limit' level is only active during motor starting.
- 2 It is recommended that the control supply is maintained between starts to ensure the integrity of the overload, which will reset on it's removal

SFE3

Soft Start Motor Controller

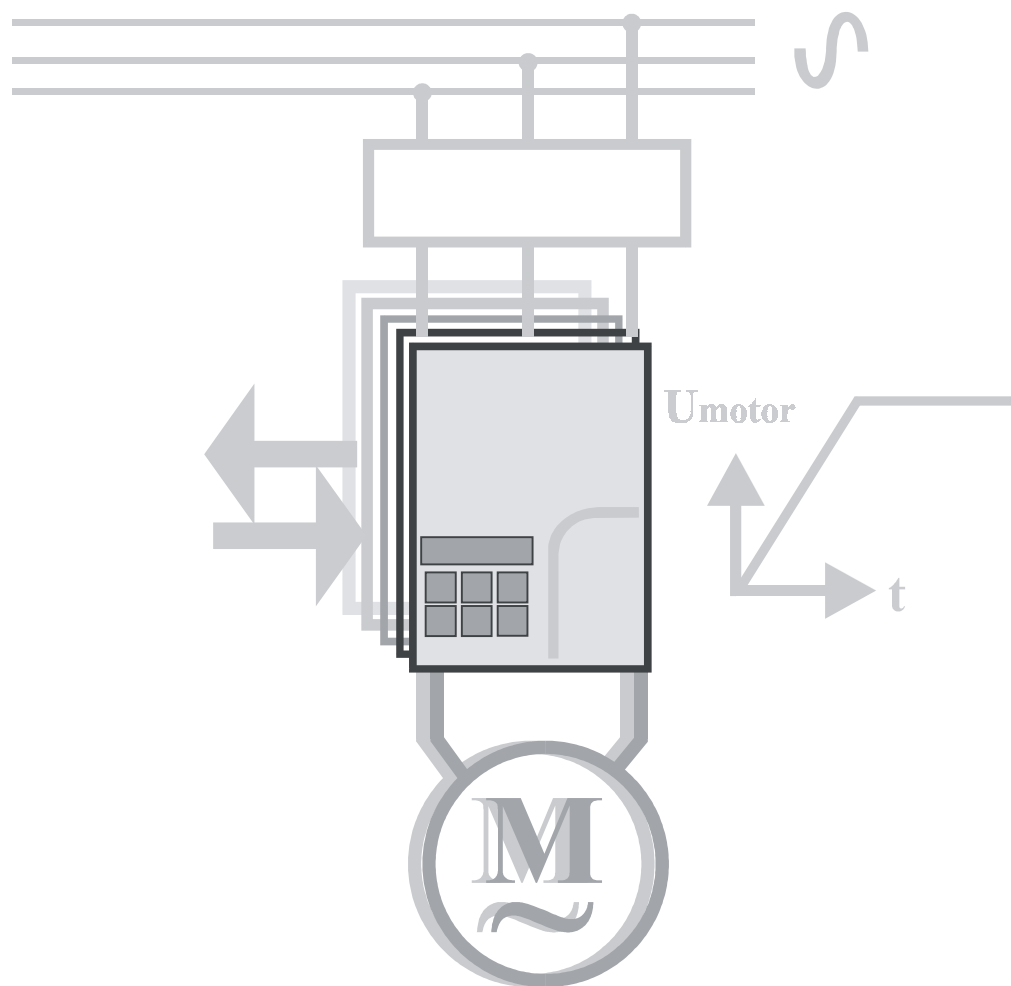

Technical Data for the SFE3 and SFE3plus
Applications

FD8414 issue03_C

3	Applications	3-5
3.1	Motor Suitability and Associated Considerations	3-5
3.1.1	Suitability	3-5
3.1.2	Induction Motor Characteristics	3-5
3.1.3	Rating	3-5
3.1.4	Maximum Motor Cable Length	3-6
3.1.5	Power Factor Correction Capacitors	3-6
3.1.6	Lightly Loaded, Small Motors	3-6
3.1.7	Motors Fitted with Integral Brakes	3-6
3.1.8	Older Motors	3-6
3.1.9	Wound-rotor or Slip-ring Motors	3-6
3.1.10	Enclosures	3-6
3.1.11	Efficiency	3-6
3.1.12	High-Efficiency Motors	3-7
3.1.13	EU Compliance with the EMC Directive	3-7
3.1.14	Fuses	3-7
3.2	Rules for Specific Applications	3-8
3.2.1	In-Delta Operation	3-8
3.2.2	High Inertia Loads	3-8
3.2.3	Phase Control Operation	3-8
3.2.4	Resistive Loads	3-8
3.2.5	Frequent Starting	3-8
3.2.6	Optimising	3-8
3.2.7	Soft-Stopping	3-9
3.2.8	Reversing Drives and Plug-braking	3-9
3.2.9	Replacement of Fluid Couplings	3-9
3.2.10	Two-speed Motor Applications	3-9
3.2.11	Multiple Motor Starting	3-9
3.2.12	Overhauling Loads	3-9
3.2.13	Application Table	3-9
3.3	Concepts and Principles of Fixed-Speed Induction Motor Starting and Control	3-11
3.3.1	Introduction	3-11
3.3.2	The Induction Motor	3-11
3.3.3	Starting Induction Motors	3-13
3.3.4	Electro-Mechanical Methods Of Starting	3-14
3.3.5	The Semiconductor Motor Controller	3-15
3.3.6	Running Induction Motors	3-16
3.3.7	Reliability Considerations	3-17
3.4	Principles of the Optimising Mode	3-18
3.4.1	Principles	3-18
3.4.2	Advantages of Energy Optimising	3-19
3.4.3	Additional Benefits in Practice	3-19
3.4.4	Optimising with the Fairford System	3-20
3.4.5	How Much Energy?	3-21
3.4.6	Estimating Energy Savings	3-22
Appendix A: Glossary of Terms		3-23
Appendix B: Power Factor Conversion Chart		3-24

3 Applications

3.1 Motor Suitability and Associated Considerations

The SFE3 soft-starter is based on the "Fairford System" of microprocessor-based optimising soft-starters which have been used world-wide in more than 100,000 critical and non-critical systems. Since 1983, Fairford System soft-starters have successfully operated with almost every type of load and environment from the Antarctic to the Jungle. The design has proven to be both reliable and adaptable, and provides a powerful mechanism with which to control fixed-speed induction motors. However, due to the intrinsic differences between electronic and electro-mechanical starting systems, there are a number of simple rules and observations to follow when using the SFE3 soft-starter. This section introduces guidelines for the user and those incorporating the unit as part of their system design.

3.1.1 Suitability

In principle, any induction motor can be started by a soft-starter. Normally, the breakaway torque of the load should be less than the full-load torque of the motor, unless a motor with a high locked rotor torque characteristic is employed. As a quick assessment, any load which has a low or no-load start with a moderate starting time, or which can be started with a star-delta starter, auto transformer or other forms of reduced-voltage starting, can be considered to be a potential application for a soft-starter.

3.1.2 Induction Motor Characteristics

Induction motors are required to provide sufficient torque to accelerate the motor and its load from standstill to full speed and to maintain full speed efficiently at all torque levels up to the design full load torque. Most modern induction motors have characteristics that are wholly suitable for use with soft starters, however, the characteristics vary considerably between different manufacturers and design types. It is important that the motor is capable of providing sufficient torque to drive the load at all speeds between standstill and rated speed, to enable the SFE3 to function properly. It is particularly important that the motor to be soft started does not have a low pull-up or saddle torque otherwise the load may not be accelerated correctly.

The primary function of the soft-starter is to act as a torque-regulating device. It cannot apply a torque greater than that which the motor generates. For this reason, problematic applications for which many different starting methods have been tried but failed, may need analysis of the motor or load performance before a soft-start can be successfully applied.

3.1.3 Rating

For most applications, except high inertia loads, the starting demands and the inertia of the rotating masses are small enough to be insignificant. This means that no special consideration needs to be given to the rating of the soft-starter, other than to ensure that it is equal or marginally greater than the rated voltage and current of the controlled motor.

Alternatively, if the number of poles of the motor and the moments of inertia of the load (J_{load}) and motor rotor (J_{motor}) are known, a soft-starter will be suitable if the figures comply with the criteria given in the bottom row of following table.

Number of Poles	2	4	6	8
Synchronous speed (rpm)	3000	1500	1000	750
$(J_{load}) / (J_{motor})$ less than	5	15	20	25

Table 3.1.3

Section 3.2.13 contains a table showing the more common applications.

3.1.4 Maximum Motor Cable Length

The length of the cable between the output terminals of the starter and the motor should not normally be greater than 100 metres. For use with longer cable runs contact your supplier.

3.1.5 Power Factor Correction Capacitors

Power factor correction capacitors applied to a single motor **MUST** always be connected by a separate contactor placed on the SUPPLY side of the SFE3 soft-start. Capacitors should be switched in after top-of-ramp (full line voltage) is reached and switched out of circuit before a stop is initiated.

It is important that any total system PFC scheme that automatically corrects for a range of inductive loads is not operated in such a way as to leave it heavily over compensated since this might introduce oscillations leading to damaging over-voltages.

3.1.6 Lightly Loaded, Small Motors

Lightly loaded, small-sized (less than 2kW), star connected motors can produce high voltages at the motor terminals when shut down by simply opening the line contactor. As these voltages can damage the soft-starter, it is safer to control the opening of the line contactor with the soft start run relay contacts.

3.1.7 Motors Fitted with Integral Brakes

Motors that include an integral, electrically operated brake, internally connected to the motor input terminals, can only be soft-started when the brake is re-connected to the supply through its own contactor.

3.1.8 Older Motors

The action of the fully-controlled soft-starter introduces harmonic currents and voltages to the motor. It is therefore, important to ensure that the motor employs techniques such as rotor skewing in its construction to suppress the effects of harmonic fluxes and avoid rough starting. This is rarely a problem with modern motors because nearly all motors designed in the last 20 years employ these techniques.

3.1.9 Wound-rotor or Slip-ring Motors

Slip-ring induction motors **ALWAYS** need some resistance in the rotor circuit to ensure that sufficient rotational torque is generated to overcome any alignment torque, which is present at start-up. The resistance can be safely shorted out in the normal fashion with a contactor controlled by the programmable relay set as 'top-of-ramp' contacts.

3.1.10 Enclosures

Thyristors are not perfect conductors, and the passage of current through them causes heat dissipation in the body of the device, which in turn causes the heatsink temperature to increase. As a rough guide, the heat generated is 1 watt/amp/phase, which equates to a dissipation of 30 watts from the heatsink for a line current of 10 amps. Therefore, all cabinets or enclosures that house soft-starters should have adequate ventilation. (Refer to the Mechanical installation procedures, section 1.6 to 1.8 for more detailed information.)

3.1.11 Efficiency

Although the use of the soft-start introduces a power loss, the system still retains an overall efficiency of approx. 99.5%. If the optimising function is selected, then the gain in motor efficiency at part loads is far greater than the loss of efficiency arising from thyristor heat losses. If prolonged operation at full load is expected, the thyristor loss can be eliminated (as in some matched motor/pump drives) by closing a bypass contactor around the soft-starter. (This contactor is readily controlled by the programmable relay set as 'top-of-ramp' contacts as the circuit in section 2.4.1 shows.)

3.1.12 High-Efficiency Motors

Due to an inherently steep front to the speed/torque curve, high efficiency motors can exhibit instability when lightly loaded and the optimising rate parameter P19 may need adjusting to compensate.

3.1.13 EU Compliance with the EMC Directive

When considering the use or fitting of any Soft Starter, users and installers in European countries must comply with the EMC Directive 89/336/EEC. The manufacturer of the soft-starter has a statutory obligation to provide a guide for compliance with this directive.

For the SFE3, this guidance is given in the EMC guide which is section 4 of this manual. It is essential that users and installers understand and comply with the requirements described in these sections.

3.1.14 Fuses

Circuit protection fuses should be rated to allow for the extended start times associated with the use of a Soft Starter. Traditional HRC motor fuses may need to be rated higher than the motor rated current for normal low-inertia applications but modern “extended start” fuses will generally give full motor protection. See also section 3.2.2 relating to high inertia loads.

Semiconductor fuses are available for the short circuit protection of the thyristors in the SFE3. See section 2.10 of the Electrical Installation manual for Semiconductor fuse recommendations and details of the Overload incorporated into the SFE3.

3.2 Rules for Specific Applications

3.2.1 In-Delta Operation

The SFE3 control system allows the soft-start to be installed “in the delta” connections of the motor, which can permit the use of a lower current rated unit. However, in this mode of operation, it is important that the soft start is connected in accordance with the relevant wiring diagram. The connection diagram in figure 2.3.2 of the Electrical Installation manual gives detailed instruction for this configuration. If motor rotation is incorrect, the connections should be changed as detailed in fig 2.3.2. It should be noted that six connections are required between the motor and soft-start. Parameter P6 must be set to 1 for delta mode which also disables the optimising.

3.2.2 High Inertia Loads

High inertia loads such as centrifugal and axial fans, grinders, flywheel presses, etc., may require a larger size of soft-start than the motor. For example, a 75kW starter may be needed for a 55kW motor. This is necessary to allow for the extra heating effects of the prolonged over-current on the thyristors during the extended starting time. If very high inertia loads are involved, then an analysis of the starting characteristics should be made. This will require accurate data about the motor speed-torque and speed-current characteristics as well as the load characteristics. For further information, consult your supplier.

Consideration must also be given to thermal overload and fuse protection systems when extended start times are involved. This must be as for heavy duty starting, as a standard thermal overload will trip under these conditions. A heavy-duty start thermal overload or an electronic overload with dual settings for start and run is recommended. Modern HRC motor fuses will allow for some overload during the start, but the fuse curve, giving time/current data, will give an indication of suitability for the particular application.

3.2.3 Phase Control Operation

Certain applications such as voltage regulators, transformers, heaters, lighting banks require the load to be controlled manually or from the 4 to 20mA or 0-10V inputs. The SFE3 soft-starter is designed to work with these applications. (Please refer to your supplier for further information.)

3.2.4 Resistive Loads

Many resistive loads can be controlled using the “phase angle control” feature of the SFE3. Some resistive loads may require different forms of control such as burst-firing, for which the SFE3 soft starter is not designed. (Please refer to your supplier for further information.)

3.2.5 Frequent Starting

High starting frequencies require careful consideration of the soft-start thermal capabilities. In many cases a standard sized SFE3 may be suitable as start times are generally shorter for this type of application. If this is not the case then a larger soft-start may be required. (Please refer to your supplier for further information.)

3.2.6 Optimising

Drives which operate for long periods of time at less than their rated capacity can benefit from the energy saving function (optimising) of the SFE3 which will adjust the thyristor triggering to reduce the excitation losses of the motor. This will lower the running temperature of the machine and help to extend it's life. See Section 3.4 Principles of the Optimising Mode.

3.2.7 Soft-Stopping

Soft-stopping can reduce positive surge pressures in pipelines on shutdown. It is necessary to make sure that the ramp-down time is long enough to remove the energy from the fluid before the firing of the thyristors is stopped, otherwise the surge pressure may still be present. Soft-stopping can also be successfully applied to loads such as conveyer belt systems where sensitive items such as bottles are being transported.

3.2.8 Reversing Drives and Plug-braking

SFE3 soft-starters used in conjunction with contactor controlled reversing and plug-braked motors show considerable benefits to the user by reducing mechanical and electrical stresses, particularly when utilising the current limited start feature. It is required, with this type of application, to insert a 150 to 350 millisecond delay between the opening of one contactor and the closing of the other, to allow any residual flux in the rotor to die away. When plug-braking, there should be some form of zero-speed detection to stop the drive after braking has been completed, otherwise the drive may either accelerate the motor in the reverse direction or switch off before zero speed has been reached. The SFE3 has a dual parameter setting feature which is particularly useful in plug-braking where the braking settings need to be different from the normal starting ramp time and current limit level. See section 2.4.4 and figure 2.4.6 of the Electrical Installation manual for details.

3.2.9 Replacement of Fluid Couplings

Soft-starters can replace fluid couplings yielding benefits of higher efficiency running and lower costs to the user. If the coupling is used to magnify the available breakaway torque, it may be necessary to replace the fitted motor with another of a larger size or one with a high starting torque characteristic before a soft-start can be employed.

3.2.10 Two-speed Motor Applications

Two speed motors, whether Dahlander connected or with dual windings, can be soft started at each speed, provided that the start is initiated when the actual motor speed is less than the synchronous speed for the winding selected. This is particularly important when changing from high to low speeds. Of particular benefit in the SFE3 is the dual setting feature, which allows different operating settings for the high and low speeds and the ability to switch rapidly between them.

3.2.11 Multiple Motor Starting

See section 2.4.2 of the Electrical Installation manual for details.

3.2.12 Overhauling Loads

Certain applications can over-speed the motor as part of normal operation. Power flow is then from the motor to the supply. It is important that the optimising is disabled during the over-speed condition and reinserted during normal conditions.

3.2.13 Application Table

The table on the following page shows many common motor applications that suit the SFE3 soft-starter. It lists typical breakaway torque requirements as a percentage of motor full-load torque (FLT). For the most satisfactory soft-start in a given application, the motor should have a full-voltage locked-rotor-torque (LRT) that is at least twice the breakaway torque. (E.g. For a reciprocating compressor the FLT is normally in the region of 50% motor LRT.) As a general rule, the higher the motor LRT is above the load breakaway torque, the greater the control over the starting process.

Application	Breakaway Torque (%FLT)	Remarks
Agitator	35	
Air compressor- rotary, unloaded start	25 - 35	
Air compressor- reciprocating, unloaded start	50 - 100	
Air compressor- screw type, unloaded start	30	Usually two-pole motor
Ball mill	30 - 50	Eccentric load, needs high starting torque motor
Carding machine	100	Often high inertia
Centrifuge	50 - 90	Usually high inertia
Centrifugal fan- dampers closed	10 - 25	Usually high inertia
Centrifugal fan- dampers open	10 - 25	Usually high inertia, very long ramp times
Centrifugal blower- valve closed	25 - 35	
Centrifugal blower- valve open	30 - 40	Can have long ramp time
Chillers	10 - 25	Usually started unloaded, two-pole motor
Conveyor- horizontal, unloaded	10 - 50	
Conveyor- horizontal, loaded	100- 150	
Conveyor- vertical lifting, unloaded	50 - 85	
Conveyor- vertical lifting, loaded	100- 175	
Conveyor- vertical lowering, unloaded	10 - 40	
Conveyor- vertical lowering, loaded	10 - 25	
Crusher (not rock)- unloaded	25 - 75	Can be high inertia
Drilling machine- unloaded	10	
Escalator- unloaded	25 - 50	Optimising feature can be effective
Fan, axial-flow propeller	20 - 40	
Feeder- screw	100- 175	Needs high starting torque motor
Feeder- vibrating, motor driven	100- 150	Needs high starting torque motor
Grinder- unloaded	10 - 25	Usually high inertia
Hammer mill	20 - 125	Eccentric load, needs high starting torque motor
Mills- flour etc.	30 - 50	
Mixer- dry contents	35 - 75	
Mixer- fluid contents	10 - 40	
Mixer- plastic contents	75 - 125	High torque motor offers advantage
Mixer- powder contents	75 - 125	High torque motor offers advantage
Pelletisers	50 - 100	
Press, flywheel	50 - 150	Needs high starting torque motor
Pump- centrifugal	10 - 25	Soft stopping useful
Pump- positive displacement, piston type	100- 175	Needs high starting torque motor
Pump- vane type, positive displacement	100- 150	Needs high starting torque motor
Rolling mill	30 - 50	
Saw, band	10 - 35	
Saw, circular	25 - 50	May be high inertia. Plug brake may be useful
Screen, vibrating	30 - 60	
Travelators, walkways	25	Unloaded starting
Transformers, voltage regulators	Nil	Change firing mode
Tumblers	30 - 100	Can be eccentric load, may need high torque motor

Table 3.2.13 Applications

3.3 Concepts and Principles of Fixed-Speed Induction Motor Starting and Control

Since its invention one hundred years ago, the standard 3-phase induction motor has become one of the most familiar items of industrial equipment ever known. Due to its simplicity of construction, low cost, reliability and relatively high efficiency, it is likely to remain the prime source of mechanical energy for the foreseeable future.

3.3.1 Introduction

Energy conversion, from the electrical supply to rotating mechanical energy, is a characteristic of all motors. To regulate energy flow, most motor circuits require a mechanism to connect and disconnect them from their electrical power source; electro-mechanical switches, known as 'Contactors', are the standard means of achieving this control. Even today, more than one hundred years after their introduction, contactor-based systems remain the most widely used method of motor control.

Nevertheless, there is a definite trend towards more sophisticated electronic systems of control being applied to fixed-speed motor drives. This section will discuss these newest forms of control - namely, electronic, microprocessor-controlled, optimising soft-starters such as the SFE3.

Note: Since there is a wealth of detailed literature available in the technical press, it is not proposed to dwell too heavily on the specifics of realising the electronic control system, but rather, to offer an outline of its various capabilities.

3.3.2 The Induction Motor

In order to appreciate the benefits of using an electronic controller, it is important to have some understanding of the characteristics and limitations of the induction motor and the electro-mechanical systems currently used to control them.

The standard, fixed-speed induction motor fulfils two basic requirements:

To accelerate itself and its load to full speed (or speeds with multi-speed motors)

To maintain the load at full speed efficiently and effectively over the full range of loadings.

Due to the constraints of materials and design, it can be difficult to achieve both objectives effectively and economically in one machine.

So, how does a motor start in the first place? As mentioned earlier, motors convert electrical energy drawn from the power supply into a mechanical form, usually as a shaft rotating at a speed fixed by the frequency of the supply. The power available from the shaft is equal to the torque (moment) multiplied by the shaft speed (rpm). From an initial value at standstill, the torque alters, up or down, as the machine accelerates, reaching a peak at about two-thirds full speed, finally to become zero at synchronous speed. This characteristic means that induction motors always run at slightly less than synchronous speed in order to develop power - the 'slip speed' and, hence the term asynchronous. The following graph is of an induction motor torque/speed curve and illustrates this most important characteristic.

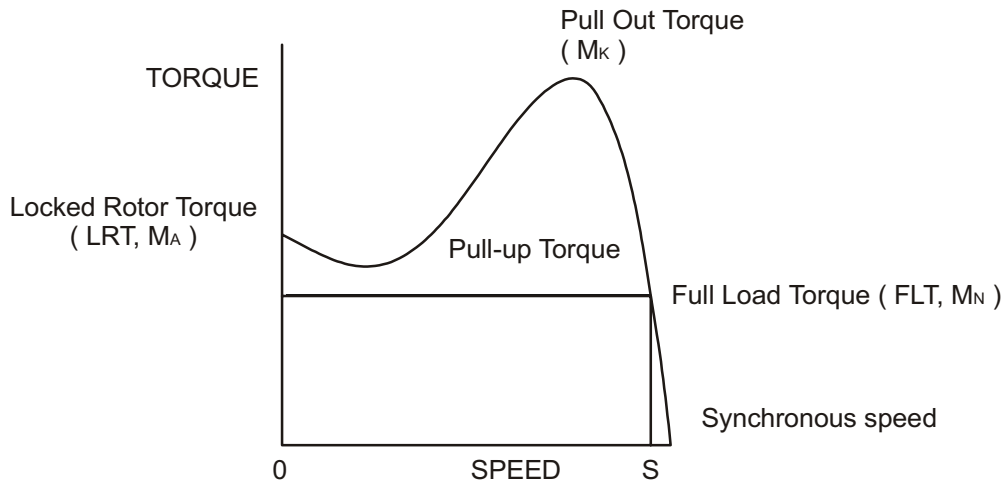

Figure 3.3.2.1 Torque/Speed Curve - Induction Motor

As for each type of motor, so each load coupled to an induction motor has its own speed/torque curve:

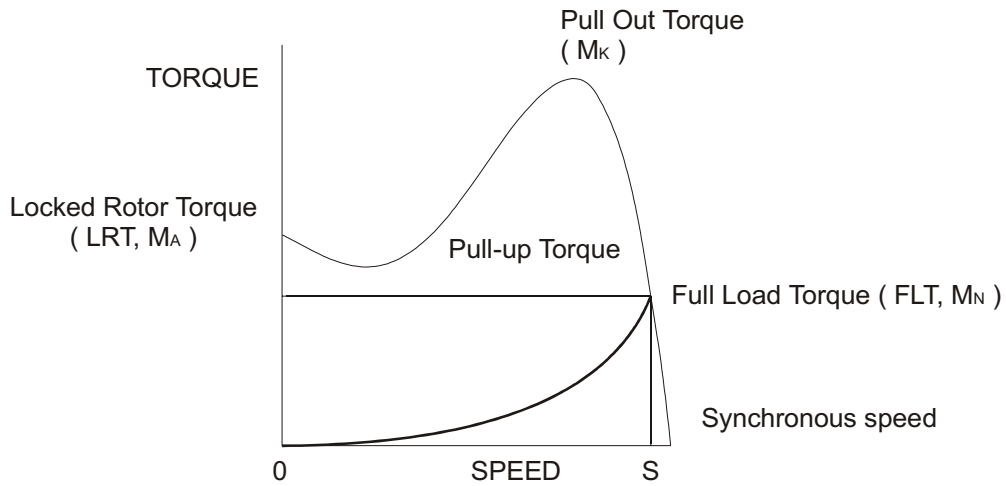

Figure 3.3.2.2 Torque/Speed Curve - Coupled Load

The acceleration of a motor-load system is caused by the difference between the developed torque (motor) and the absorbed torque (load) and is shown by the shaded area in the next figure:

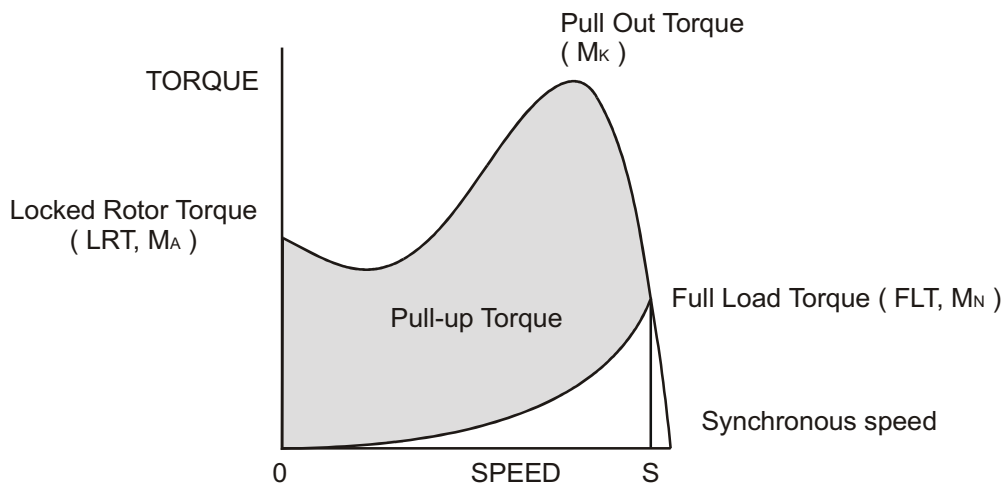

Figure 3.3.2.3 Torque/Speed Curve - Accelerating Torque

Obviously, the larger the difference, the faster the acceleration and the quicker full speed is reached - and, coincidentally, the greater the stresses experienced by the supply and drive systems during the acceleration process. An “ideal” start would accelerate the load with just sufficient force to reach full speed smoothly in a reasonable time, and with minimum stress to the supply and drive mechanisms.

Broadly speaking, the motor speed/torque characteristic is controlled by the rotor resistance - a motor with high rotor resistance can generate its peak torque (pull-out torque) at standstill giving the high break-away torque characteristic, which reduces steadily as the speed increases and becoming zero at synchronous speed. At the other end of the scale, a motor with a very low rotor resistance will produce a low starting torque but will generate its peak torque closer to the synchronous speed. Consequently this type of motor runs at full power with higher operating efficiency and low slip speed. It is possible to combine the twin requirements of high starting torque and efficient full-speed operation within a single motor by techniques such as double-cage or deep bar design, and this, usually, is the motor characteristic chosen for lifting and hoisting applications:

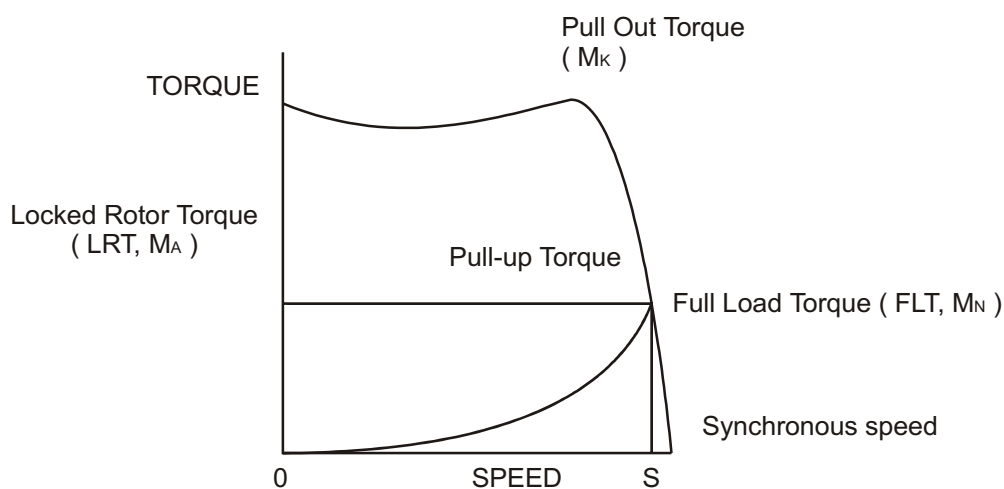

Figure 3.3.2.4 Torque/Speed Curve - High Starting Torque

However, most induction motors are designed to have a “standard” characteristic that provides a compromise between starting torque and operating efficiency. To summarise, an induction motor will only start and accelerate when it produces more torque than the connected load absorbs. This is true for all speeds - including standstill and full speed.

3.3.3 Starting Induction Motors

Starting a de-magnetised induction motor from standstill is a demanding and complex process. At the instant of switching all the energy necessary to magnetise the motor, to provide the acceleration force, and to supply the kinetic energy of the rotor and load, must be present together with the energy to overcome the mechanical and electrical losses. To do so at full supply voltage places considerable stresses on the supply, the motor windings, and the iron cores of the stator and rotor. Excessive acceleration of a rotor when the mechanical load is small can produce torque oscillations in the shaft causing severe wear to transmissions, gears and drives. Excessive acceleration when the load inertia is high such as in centrifugal fans, causes belts to slip in the pulleys, producing rapid wear and early failure.

3.3.4 Electro-Mechanical Methods Of Starting

Method A: Direct-on-Line

The most simple means of controlling energy flow to an induction motor is to interrupt the power supply by a single, solenoid operated, 3-phase switch, known as a contactor. Very widely applied, the method is known variously as “direct-on-line”, “across-the-line”, “direct” etc., and is the usual form of control where low cost is the first, and most important consideration. As a result, it is most often used on small motor sizes (up to approx. - 22kW), or where the supply is strong enough to withstand the inrush and starting current surges without causing unacceptable voltage drops.

The harsh, damaging effects described earlier are all imposed by direct-on-line starting and, as a control method, it is the most destructive of equipment. Its simplicity and apparent low cost, although attractive at first sight, hide large cost penalties in the shape of increased maintenance, reduced transmission equipment life and higher risk of motor failure, particularly when frequent starting and stopping is needed. In larger sized motors special strengthening is necessary, at higher cost, before they can be safely used with direct-on-line starting.

However, the shortcomings of the direct-on-line starter have been recognised ever since motors have been used and alternative systems have been developed over the years to reduce the damaging effects of this form of control.

Method B: Star-Delta and other Reduced Voltage Starting Systems

Reduced voltage starting makes use of the fact that motor torque is proportional to the square of the terminal voltage; the most familiar type of reduced-voltage starter is the star-delta starter.

Consisting of three contactors and a time switch (which can be mechanical, pneumatic, electrical or electronic), the star-delta starter changes the motor winding configuration from an initial star connection to a delta as the motor accelerates. The change-over or transition point is controlled by the time switch and is usually arranged to be approximately at 80% of full speed. The effect of starting in star is to alter the voltage across each stator winding to 58% of normal. This reduces the starting torque to a third of locked rotor torque (LRT) with a consequent reduction in starting currents and acceleration forces.

Although an apparent improvement over the direct system, significant disadvantages still remain. The transfer from star to delta momentarily removes the motor from the supply. During this time the motor is under the mechanical influence of the rotating load and, at the instant of disconnection, current will still flow in the rotor bars due to the time delay necessary for the magnetic flux to die away. Therefore, there is a residual flux “frozen” on the surface of the rotating rotor, which cuts the stator windings, generating a voltage whose frequency depends on the rotor speed. If the load inertia is small, such as in a pump, or if the friction is high, there could be a significant loss of speed during the time the supply is disconnected.

In this case, when the reconnection to delta is made, a large phase differential can exist between the supply and the rotor fluxes. This can give rise to very large current surges (as much or more than full-voltage locked rotor current), together with massive transient torque oscillations, which can peak at levels in the region of fifteen-times full-load torque. Although the effects described are only present for a very short period of time (about one fifth of a second), they are sources of great stress and damage to the whole drive system, and where frequent starting is necessary, invoke high maintenance costs. The current surges, in the form of a very high level short duration “spikes”, are an increasing problem in these days of computer control systems and other “sensitive” electronic equipment. The voltage disturbance on the supply is very difficult to filter out and can cause severe problems, especially when larger motors are involved.

There are methods of control, for example, the Wauchope starter, which eliminate or reduce the reconnection transients. However, such starters are expensive and have reliability implications; for these reasons they are not widely applied.

The star-delta starter also has disadvantages due to the restricted starting torque available (if you need 40% LRT to break-away, you can only increase the motor size, or revert to direct-on-line). Combined with the severe effects of the re-switching surges, and the additional costs of bringing six conductors from the motor to the starter instead of only three, star-delta only offers an imperfect solution to the problem of starting the induction motor.

Method C: Primary Resistance Starter

It has long been recognised that the transition step in the star-delta system was a source of problems such as welded contactors, sheared drive shafts etc., and for many years a method of stepless control has been available in the form of the primary resistance starter.

This type of controller inserts a resistance in one, or more often in each, of the phase connections to the stator at start-up, after which it is progressively reduced and shorted out at the end of the acceleration process. Frequently, the resistances are movable blades that are gradually inserted into an electrolyte liquid. The mechanism is usually large and expensive, both to purchase and to maintain, and considerable heat is created by the passage of current through the electrolyte resistor. This limits the starting frequency (because the electrolyte has to condense back to liquid before a new start can proceed), and these restrictions prevent this starter from being a popular option when selecting a control system. However, it has the distinction of being the smoothest and least stressful method of accelerating an induction motor and its load.

Method D: Other Electro-Mechanical Systems

Other control methods such as auto-transformer starting (popular in North America), primary reactance starting etc., are employed to a greater or lesser extent, to compensate for some of the disadvantages of each type of starter discussed. Nevertheless, the fundamental problems of electro-mechanical starters remain, and it is only in the last decade or two that their dominance has been challenged by the introduction of power semiconductors controlled by electronics.

3.3.5 The Semiconductor Motor Controller

During the 1950's, much effort was put into the development of a four-layer transistor device which had the power to switch large currents at high voltages when triggered by a very small pulse of current. This device became known as the silicon controlled rectifier (SCR), or in Europe, the 'Thyristor'; it is the basis on which all soft starting systems are built. The characteristic of most interest is the ability of the thyristor to switch rapidly (in about 5 millionths of a second) from "OFF" to "ON" when pulsed, and to remain "ON" until the current through the device falls to zero, - which conveniently, happens at the end of each half-cycle in alternating current supplies.

By controlling the switch-on point of a thyristor relative to the voltage zero crossing in each half wave of an alternating current, it is possible to regulate the energy passing through the device. The closer the turn-on point is to the voltage zero crossing point, the longer the energy is allowed to flow during the half-cycle. Conversely, delaying the turn-on point reduces the time for the energy to flow. Putting two thyristors back-to-back (or anti-parallel) in each of the phase connections to a motor, and by precisely controlling their turn-on points, an electronic soft starter continuously adjusts the passage of energy from the supply so that it is just sufficient for the motor to perform satisfactorily.

So, for instance, by starting with a large delay to the turn on point in each half cycle, and progressively reducing it over a selected time period, the voltage applied to the motor starts from a relatively low value and increases to full voltage. Due to the motor torque being proportional to the square of the applied voltage, the starting torque follows the same pattern giving the characteristic smooth, stepless start of the soft-starter.

3.3.6 Running Induction Motors

Once a start has been completed the motor operating efficiency becomes of interest. When working at or near full load, the typical 3-phase induction motor is relatively efficient, readily achieving efficiencies of 85% to 95%. However, as shown below, motor efficiency falls dramatically when the load falls to less than 50% of rated output.

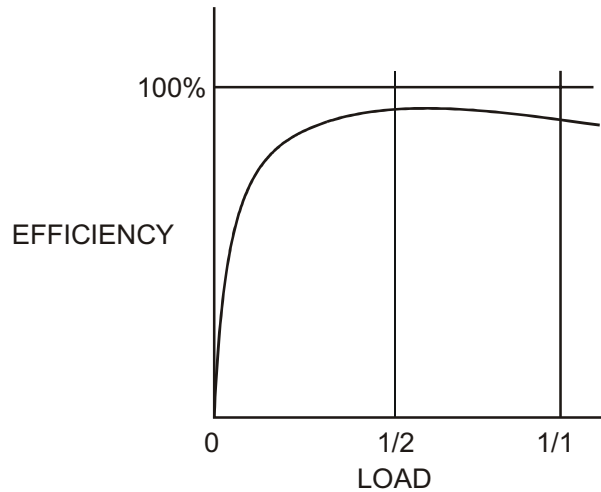

Figure 3.3.6.1 Motor Efficiency/Load Characteristic

In fact, very few motors actually experience consistent fully rated operation, the vast majority operate at much lower loads due to either over-sizing (a very frequent situation), or natural load variations. For Fan and Pumping applications, the affinity laws will allow the inverter drive to show very considerable energy savings over virtually all other methods of control through varying the speed of the motor in response to changes in load. Where motor speeds cannot be varied, an optimising version of semiconductor motor controller, such as the SFE3 will also produce energy savings in lightly loaded motors. Less sophisticated systems of soft-starter remain at full conduction and the motor then behaves as if it were connected directly to the mains supply. However, at light loads and mains voltages, induction motors always have excess magnetic flux, and efficiency loss and power factor degradation result. By detecting the load at any instant, and adjusting the motor terminal voltage accordingly, it is possible to save some of the excitation energy and load loss, and improve motor power factor when the motor is running inefficiently at light loads.

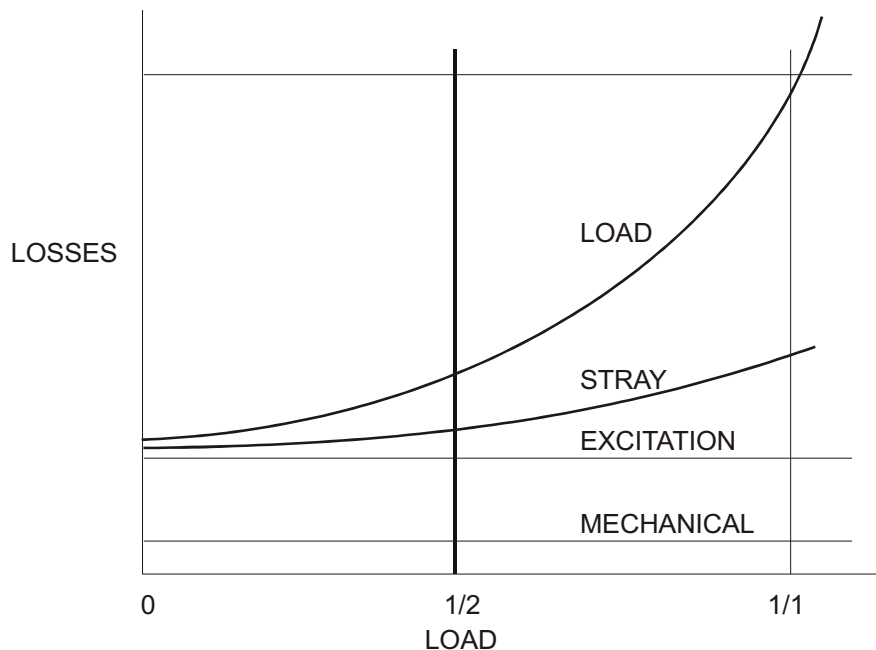

Figure 3.3.6.2 Motor Efficiency/Loss Characteristic

All SFE3 soft-starters are microprocessor controlled, and this gives them a number of advantages. Firstly, there are no adjustments to be made for the energy saving function: all calculations necessary to find the best degree of phase-back of the thyristors for any load condition is made by the microprocessor. Secondly, the start always synchronises with the supply voltage and a special structure of turn-on pulses virtually eliminates the inrush currents normally associated with motor start-up; this happens every time. Lastly, there is the absolutely stepless starting process, found only with the primary resistance or reactance electro-mechanical starters - but without the wasted energy, and with the opportunity to control the maximum current allowed to flow during the starting process. Other features such as soft stopping are included to give considerable control over all modes of induction motor operation.

3.3.7 Reliability Considerations

An aspect of electronic controllers for induction motors which is of increasing concern is that of reliability. There is little point in installing an expensive item of electronic equipment to save potentially considerable amounts of money if the device is unreliable to the point that vital processes are constantly interrupted.

There are electronic products in the market place which appear to offer soft starting cheaply. They almost always rely on less advantageous technologies such as analogue control, or half-control, where one of the two thyristors in each phase is replaced with a diode. There are systems which only control the energy flow in one phase while the other two are directly connected. Owing to the variable quality and performance of many so-called inverters and soft-starters available to the unsuspecting purchaser, international standards for these products have been developed.

So far, IEC 60947-4-2 - 'AC Semiconductor Motor Controllers and Starters' defines the soft-starter in every important respect, including thermal and overload performance as well as electromagnetic compatibility. By ensuring that any motor controller equipment purchased conforms to IEC 60947-4-2, a user should be reasonably safeguarded from shoddy or inadequate products when specifying equipment for future installations.

A particular advantage of the use of the optimising soft starter is its impact on the maintenance requirements of associated electro-mechanical equipment. Optimising lowers the surface temperature of the motor by reducing the losses within the motor. This prolongs the motor life - and reduces heating of the surrounding atmosphere in the process. If the atmosphere is subject to air conditioning, reducing the heat input will reduce the air conditioning costs. Reduced starting and running currents reduces cable losses and, contactor switching operations are carried out under the most advantageous conditions. No current flows on switch-on since all switching is carried out by the thyristors - virtually eliminating the need for contact replacement.

Indeed, there are a growing number of installations where contactors are no longer employed, being replaced by controllable circuit breakers or isolators instead.

In summary, electronic controllers for most fixed-speed applications are opening new ways of increasing the efficient operation of induction motors, as well as offering significant benefits in control. Intending users need to ensure themselves of the quality and performance of any products they expect to fit and this can be reasonably expected if compliance with the appropriate IEC standards is demanded.

3.4 Principles of the Optimising Mode

3.4.1 Principles

Every wound-field electric motor must consume some minimum amount of energy to provide a magnetic field which enables it to work at all. With DC motors the field is under separate control, so that the amount of magnetising energy can be adjusted to be sufficient to overcome losses and provide an armature reaction appropriate to the load. The squirrel cage AC induction motor has no such provision, with the result that at any load less than it's rated full load (at full speed), energy is wasted. When a squirrel-cage motor is supplied at a constant terminal voltage, as when it is connected directly to the supply without a controller of any kind, the strength of the field flux is fixed by the supply voltage. At normal running speed the field will take a fixed quantity of energy regardless of the torque demanded by the mechanical load. The energy required to support the load torque is determined by the torque demand. As load torque increases, the rotor slows down a little (ie 'slip' increases), causing the induced rotor currents to increase also, and so to increase the torque. These additional currents in the rotor are balanced by additional current in the stator coils. Conversely, if load torque demand falls, the slip decreases, the rotor currents decrease, and the current in the stator decreases accordingly. But at constant terminal voltage, the current, and therefore the energy, providing the stator field flux remains unchanged at any level of load torque demand. As a consequence, the efficiency of an induction motor falls as the load falls.

Fig. 3.4.1.1 shows a typical duty cycle for a machine load, where the torque demand varies.

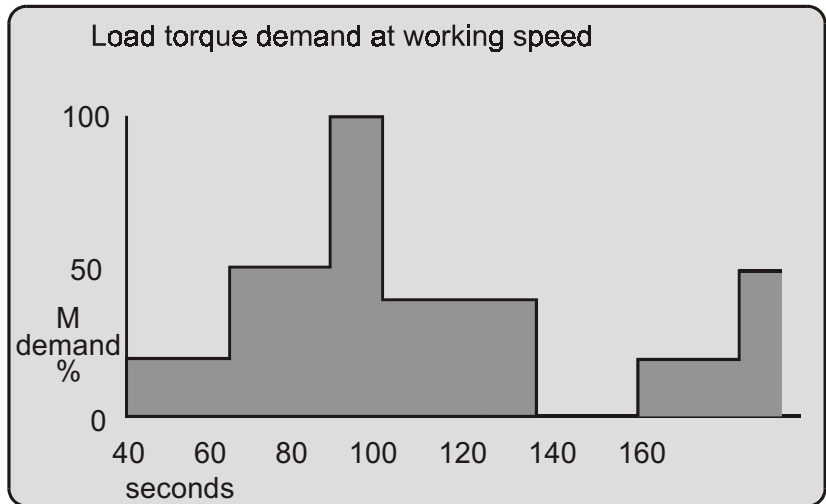
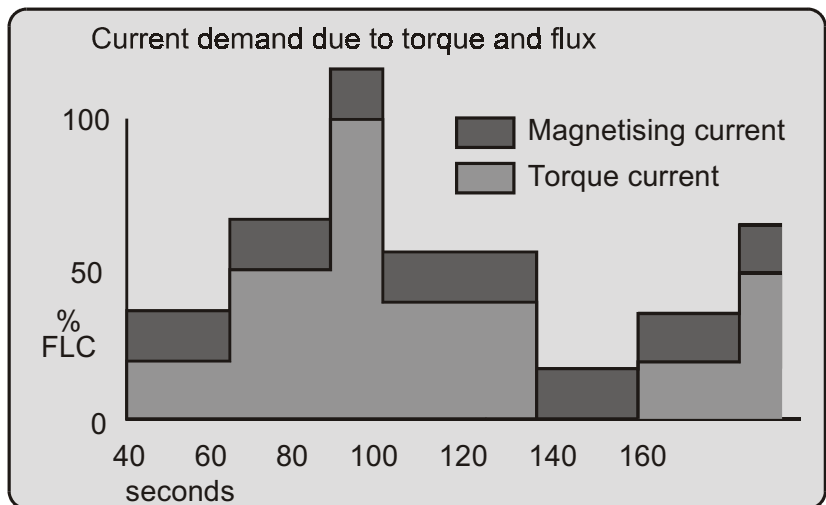

Fig 3.4.1.2 shows the torque demand converted to an equivalent current with the motor magnetising current added



3.4.2 Advantages of Energy Optimising

A soft starter with an energy-optimising feature alters the motor operation. The energy-optimising function reduces the terminal voltage applied to the motor so that the energy needed to supply the field is more-closely proportioned to the torque demand. The effect is shown in the Figure below.

The present considerations do not affect soft starting options or strategies. When the motor terminal voltage is at its 'nominal' or rated value and when the load is the maximum for which the motor is rated, the operating point of the motor on the current curve is at point A.

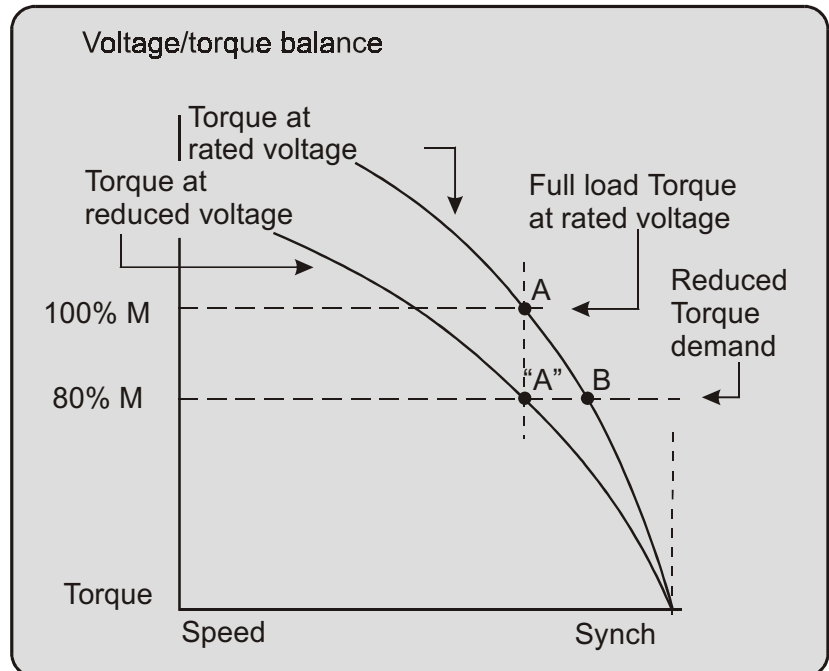

Fig. 3.4.2.1 'full speed' end of the conventional torque/current curves.

If the load falls, a motor supplied at a fixed voltage will speed up slightly, the current demand will reduce, and the operating point moves along the curve to point "B". Because the torque developed by a motor is proportional to the square of the applied voltage, lowering the terminal voltage reduces the torque. If the reduced voltage is correctly chosen, the working point at the reduced torque demand becomes the point "A". By reducing the terminal voltage, the motor has in effect been 'changed' for one which has a lower rated power output. A reduced terminal voltage also means a reduced field energy requirement and this simple relationship enables the optimising function to maintain the efficiency of the motor over nearly the whole of the load range from 'no load' upwards. In practical terms, 'no load' means no external load. There are the internal mechanical and electrical losses to be overcome - friction and windage of the rotor at speed, and the electrical heating and hysteresis losses. The ideal response to the 'no load' condition would be to supply precisely the amount of magnetising current needed to provide the armature reaction to balance the losses. This is what the energy-optimising feature of a soft starter seeks to do, continuously and automatically.

3.4.3 Additional Benefits in Practice

It is usual to select a standard motor with a rating somewhat higher than the maximum demand of the driven load. The motor selected for any given application will almost certainly be over-rated for this reason alone and therefore, when supplied at rated voltage, energy could be saved even at full load. Furthermore, there are those applications where the size of motor has to be chosen to provide for high loadings, which occur only intermittently or for an arduous start, although the load demand at other times is much less.

3.4.4 Optimising with the Fairford System

During start-up, the SFE3 software computes and stores, by a patented method, a reference value for the power factor. When the motor has reached full speed and is driving the load at the torque demanded, it enters the 'motor running' stage. At this stage, if required, the motor may also operate in 'Optimising Mode'. Entering this mode can be pre-set from the SFE3 keypad and stored for automatic operation, which will suit the majority of applications where it is required. This is the default operating mode for the SFE3. It can also be toggled on and off whilst running by using either the OPTIMISE button on the keypad or, with the SFE3plus version, through external circuitry connected to one of the programmable inputs and controlled by the driven process.

In this mode the reference power factor is continuously compared with the running power factor. From the comparison, the software continuously computes and adjusts the firing point of the thyristors so that the best power factor is maintained. This method of continuous control minimises the energy wastage caused by overfluxing the motor. It also maintains the power factor at the most appropriate value for every condition of load demand. This can effect a significant reduction in the kVA demand.

This is an operating condition that may, at light or partial load conditions, provide the benefit of energy saving and if selected, is continuous from the dwell period until a STOP command is initiated or the mode is disabled. It should be noted that this function is inhibited by the software if the current being drawn by the motor exceeds 80% of the set current of the SFE3. At full volts, when the motor enters it's running stage, with the optimising mode selected,

The method of power factor management described does not affect motor performance, neither does it detract from the motor's capability to respond to changes in load demand. This feature of the SFE3 soft-starter is a purely electrical function which has the effect of ensuring that, at all times, the motor delivers the torque demanded, but allows it to draw only the precise amount of magnetising current required to support that torque output. Without this feature, the motor would draw the maximum magnetising current regardless of load.

The optimising function cannot improve the power factor beyond what it would ordinarily be at full load, but it does make the optimum improvement possible at any part-load.

3.4.5 How Much Energy?

The amount of energy used by a squirrel cage induction motor operating with a soft starter in energy-optimising mode is shown in the following Figure, for the same duty cycle as Fig. 3.4.1.2. By reducing the voltage when torque demand is below maximum, the magnetising current is proportioned to the torque current.

Compare Fig. 3.4.5.1, energy-optimising, with Fig. 3.4.1.2, non-optimising. (These graphical representations are illustrative only and not to scale.) To arrive at any exact figure for the energy saved requires each individual case to be examined in detail, taking into account the motor rating, type, and any special characteristics, Load, load characteristics, duty cycle, supply voltage, supply authority tariffs and the user's particular terms.

Fig 3.4.5.1 Energy savings

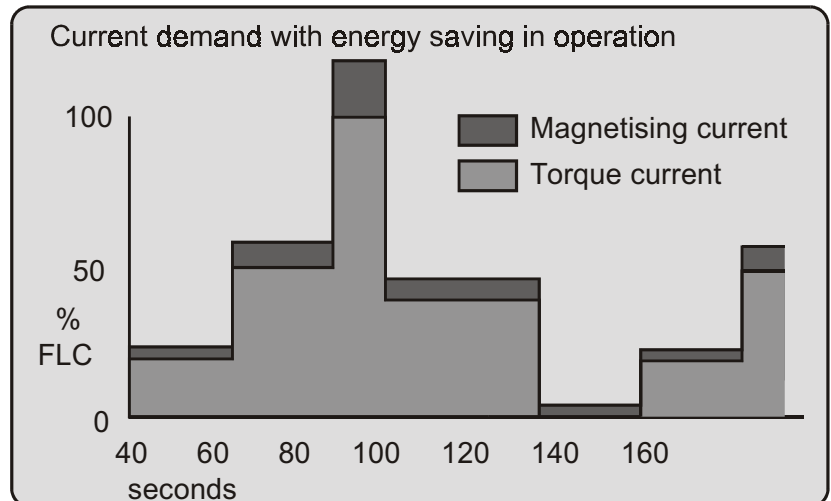

The calculations to cover all the likely or possible conditions would be laborious. An empirical method for arriving at a usefully realistic estimate has been devised by Fairford Electronics Ltd. Used with a proper sense of engineering circumspection, the following tables allow a user to gain a reasonably close estimate of the saving to be achieved within the motor by using The SFE3 optimising soft starter. The method does not include any additional savings and benefits conferred by other sources, such as -

- Reduction of *heating losses* in cabling because of the lower voltages;
- Potential reduction of *maximum demand* charges;
- Further energy saving and other benefits deriving from the soft starting process itself
- Reduced *total energy-demand*,
- reduced *wear and tear*,
- reduced *maintenance* and *replacement* costs.

3.4.6 Estimating Energy Savings

Basis for estimation

3-phase squirrel cage induction motor, standard type.

Supply: 380 to 440V, 50Hz.

Supply voltage >min. working voltage on motor rating plate.

Operation 30% rated nameplate full load.

Motor size	KW	HP	Estimated savings % rated kW
Less than	5	7.5	10
	22.5	30	6.5
	55	75	3.5
	110	150	2.5
More than	110	150	1.5

Table 3.4.6.1 Estimations

Motor poles		% slip	
Poles	Add - % kW	% slip	Add - % kW
2	-0.5	0.5	-0.5
4	0	2	0
6	0.5	3.3	0.5
8	1	5	1

Table 3.4.6.2 Modifying factors

Examples of estimated saving

1 A 37.5 kW 4-pole motor

From Table 1, use the estimated saving figure for the next higher rating, ie 55 kW.

The saving would be, approximately $3.5\% \times 37.5 \text{ kW} = 1.3125 \text{ kW}$

2 A 37.5 kW 2-pole motor

From Table 1, use the estimated saving figure for the next higher rating, ie 55 kW.

From Table 2, apply the pole-number factor of -0.5 %.

The saving would be, approximately $(3.5\% - 0.5\%) \times 37.5 \text{ kW} = 1.125 \text{ kW}$

3 A 37.5 kW 2-pole 'low slip' motor

From Table 1, use the estimated saving figure for the next higher rating, ie 55 kW.

From Table 2, apply the pole-number factor of -0.5 % and the %-slip factor of -0.5%.

The saving would be, approximately $(3.5\% - 0.5\% - 0.5\%) \times 37.5 \text{ kW} = 0.938 \text{ kW}$

Appendix A: Glossary of Terms

Breakaway Torque	The minimum torque required to achieve rotor movement for the motor with its load.
Current Limit	The current at which the ramp is held. For the SFE3, current limit is only active during start-up where it contributes to the motor control function. This feature is particularly useful when starting high-inertia loads that require an extended start-up period. (See also Overload Level.)
Direct-On-Line (DOL)	The direct connection and disconnection of a motor from the AC mains supply by means of a contactor or switch. Acceleration and operation is at full mains voltage only.
Inrush Current or Locked Rotor Current	The current that flows at the instant of connection of a motor to the power source. It is limited by the impedance presented by a de-energised motor and the applied voltage. Usually expressed as a multiple of motor full-load current.
Kick-start	Kick-start voltage is the percentage of supply voltage applied before commencing ramp-up when a load has a high breakaway torque and the standard settings of pedestal voltage may not allow sufficient torque to be developed by the motor to cause acceleration.
Overload Level	The level of current at which the controller overload begins to integrate. For the SFE3, the overload detector is always active and provides protection against prolonged over-current operation.
Pedestal Voltage	The voltage that the unit applies to the motor at start-up. It is expressed as a percentage of the rated supply voltage.
Power Factor	The ratio, expressed as a trigonometric cosine, of the real power consumption to the apparent power consumption.
Top of Ramp (TOR)	The unit achieves Top of Ramp (TOR) when it completes the start-up stage of motor control. This occurs when the voltage applied to the motor first equals the mains supply voltage.)
Soft-start	Soft-start is the regulation by electronic means, of the supply voltage from an initial low value to full voltage during the starting process. This over-comes the inherent drawbacks of a switched supply. The motor torque is modified in proportion to the square of the voltage applied.
Trip	A trip occurs when the unit removes power to the motor because its operation equals the limit imposed by one of its self-protection features.

Appendix B: Power Factor Conversion Chart

Parameter 20 is the reference power factor that the SFE3 computes during the start. Parameter 21 is the present power factor of the load. The keypad display shows each of these parameters in angular degrees.

The table below can be used to convert this value (θ , in degrees) to the power factor ($\cos \theta$).

Degrees	Power Factor	Degrees	Power Factor	Degrees	Power Factor
0	1.00	30	0.87	60	0.50
1	1.00	31	0.86	61	0.48
2	1.00	32	0.85	62	0.47
3	1.00	33	0.84	63	0.45
4	1.00	34	0.83	64	0.44
5	1.00	35	0.82	65	0.42
6	0.99	36	0.81	66	0.41
7	0.99	37	0.80	67	0.39
8	0.99	38	0.79	68	0.37
9	0.99	39	0.78	69	0.36
10	0.98	40	0.77	70	0.34
11	0.98	41	0.75	71	0.33
12	0.98	42	0.74	72	0.31
13	0.97	43	0.73	73	0.29
14	0.97	44	0.72	74	0.28
15	0.97	45	0.71	75	0.26
16	0.96	46	0.69	76	0.24
17	0.96	47	0.68	77	0.22
18	0.95	48	0.67	78	0.21
19	0.95	49	0.66	79	0.19
20	0.94	50	0.64	80	0.17
21	0.93	51	0.63	81	0.16
22	0.93	52	0.62	82	0.14
23	0.92	53	0.60	83	0.12
24	0.91	54	0.59	84	0.10
25	0.91	55	0.57	85	0.09
26	0.90	56	0.56	86	0.07
27	0.89	57	0.54	87	0.05
28	0.88	58	0.53	88	0.03
29	0.87	59	0.52	89	0.02

SFE3

Soft Start Motor Controller

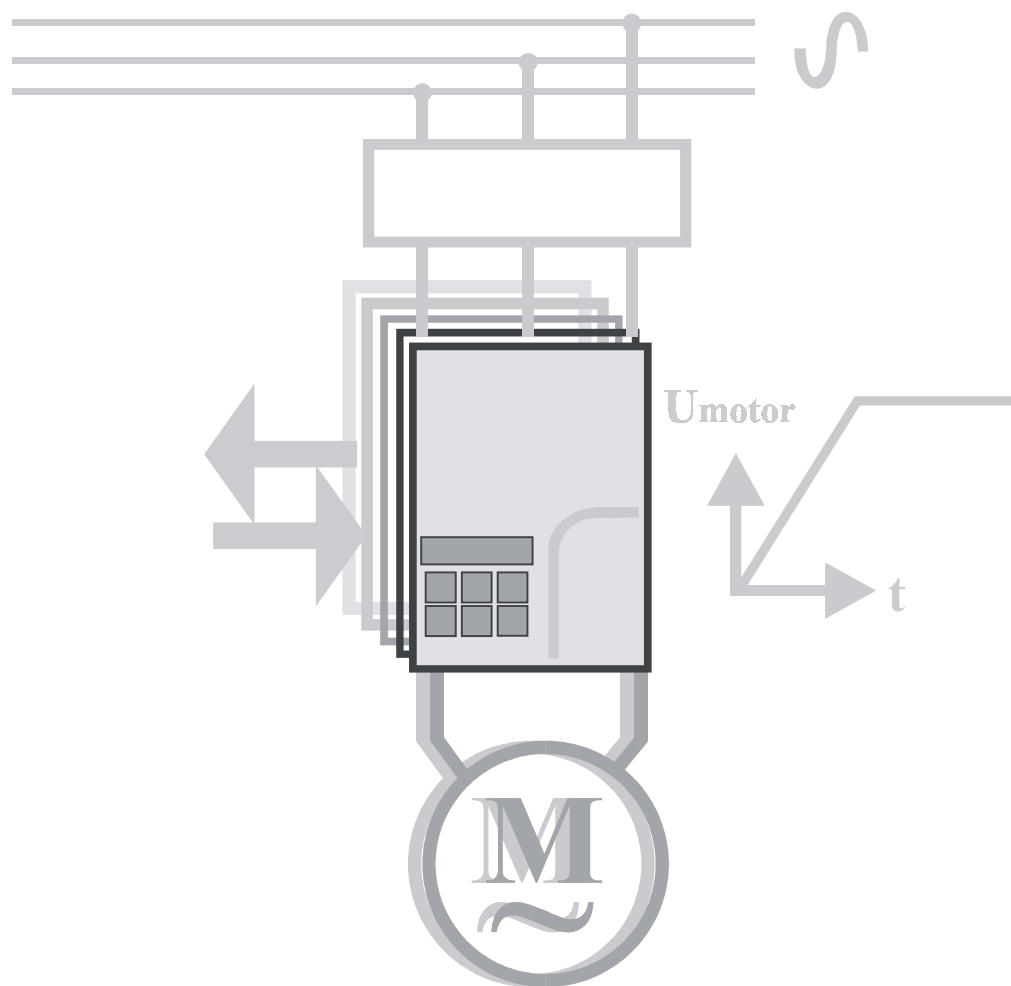

Technical Data for the SFE3 and SFE3plus
Electro-Magnetic Compatability

FD8415 issue03_C

4	Electro-Magnetic Compatibility (EMC)	4-5
4.1	Introduction	4-5
4.2	Applicable Standard within the EU	4-5
4.3	Mandatory Requirements within the EU	4-5
4.4	Guidance for Installation Personnel and System Designers	4-5
4.5	EMC - Basic Criteria	4-6
4.6	Purchasing Implications of Meeting an EMC Standard	4-6
4.7	Basic EMC Considerations	4-6
4.7.1	Immunity	4-6
4.7.2	Emissions	4-6
4.7.3	Emissions - Harmonics	4-6
4.7.4	Emissions - Radio Frequency (RF)	4-7
4.7.5	Emissions - Conducted	4-7
4.7.6	Important Systems Information:	4-7
4.7.7	Strategies in Attaining and Maintaining EMC Compliance	4-8

4 Electro-Magnetic Compatibility (EMC)

As supplied, all SFE3 and SFE3plus units meet the standards of emission and immunity levels defined in the IEC 60947-4-2 and EN 60947-4-2 product standards for AC Semiconductor Motor Controllers and Starters. However, the emc performance of the controller can be significantly affected by the manner in which it is incorporated into the system in which it is intended to operate. To prevent inadvertent degradation of emc performance, attention must be given to motor cable lengths, wiring configurations, the nature of the power supply, etc., at the design, construction and implementation stages of a project.

4.1 Introduction

It is widely accepted that electromagnetic compatibility between electronic and electrical products is a desirable objective. Technical standards are increasingly stipulating levels of EMC performance which compliant products are required to meet. The decision by the European Union (EU) to implement a community-wide directive covering EMC caused considerable activity amongst electrical and electronic equipment manufacturers and suppliers to identify, understand and mitigate the sources of electromagnetic interference within their products and systems.

4.2 Applicable Standard within the EU

The product standard which defines EMC performance for soft-starters is IEC 60947-4-2 'AC Semiconductor Motor Controllers and Starters'. (The Official Journal of the EC will list this standard as EN 60947-4-2.) The SFE3 has been type tested in accordance with the test procedures and levels laid down in the product standard.

4.3 Mandatory Requirements within the EU

(Applicable to any person involved in the installation and operation of the equipment.)

The EU Directive 89/336/EEC, describes the required EMC, performance of all electrical equipment which is to be connected to a low voltage supply network. It imposes an obligation on the manufacturer of the soft-starter to provide sufficient information for installers, system integrators, users and anyone else connected with the installation and operation of the equipment. This section provides the technical information to support the obligation of the manufacturer.

From the manufacturer the provision and maintenance of compatibility extends to the panel-builder, assembler, system integrator, and ultimately, to the installer and user. Anyone involved in the installation and operation of the equipment, through a lack of knowledge, misdirection or for other reasons, can completely negate the initial EMC performance of the equipment.

4.4 Guidance for Installation Personnel and System Designers

For safety reasons, all SFE3 products are intended to be installed and set to work by skilled personnel who are capable of interpreting and following EMC guidelines correctly. Any person not fully trained in the appropriate technology should not attempt the installation.

If you do not understand, or if you are unclear about any part of these guidelines, then please consult your supplier. Often, consultation with the supplier can avoid unnecessary problems in specifying and installing the correct combination of equipment.

4.5 EMC - Basic Criteria

The electromagnetic compatibility of a product is defined by two criteria:

- 1 Immunity to electromagnetic disturbances generated externally to the product
- 2 The type and amount of conducted and radiated electromagnetic emissions emanating from the product.

Ascertaining the nature of the power supply is of primary consideration when deciding on appropriate EMC requirements. The requirements for equipment installed in heavy industrial environments (fed from their own isolated low voltage power supply) differ from those installed in residential, commercial, light industry and health-care applications (directly connected to a public low-voltage network).

Generally, industrial installations require higher immunity levels and permit higher levels of conducted and radiated emissions than those for non-industrial installations. On the other hand, lower levels of emissions output, and lower immunity levels, are specified for installations connected directly to the public low-voltage network.

4.6 Purchasing Implications of Meeting an EMC Standard

Before purchasing components for the installation, the specifier must evaluate the expected source of power for the Soft Starter and understand exactly the implications for meeting EMC requirements. It is likely that failure to do so will result in the purchase and installation of inappropriate equipment. Close consultation with your supplier will avoid these unnecessary problems, particularly when you do not understand, or are unclear about any part of the guidelines given later in this section.

If you have any doubt, please ask.

IMPORTANT:

The information and guidance given in section 4.7 forms part of the statutory requirements of the European Union Directive 89/336/EEC on EMC.

4.7 Basic EMC Considerations

4.7.1 Immunity

The product standard for immunity requirements is EN 60947-4-2:1996. All SFE3 soft-starter products meet, or exceed the industrial level immunity requirements laid down in this standard.

4.7.2 Emissions

Emissions are classified as low frequency, (below 9kHz), known as harmonics, and high or radio frequency, (above 9kHz). Both radio-frequency emissions and low frequency harmonics are generated by the action of the SFE3 soft-starter.

4.7.3 Emissions - Harmonics

Harmonics arise from the intentional delay relative to the voltage wave zero, in the turn-on of the semiconductor switches in order to vary the voltage at the motor terminals. This introduces supply discontinuities and so generates harmonics. However, the configuration of the SFE3 soft-starter power circuits as a fully-controlled regulator (W3C), and the mode of pulsing used results in minimised harmonic effects. This means that only non-triplen, (integer multiples of the third harmonic), odd harmonic frequencies are created, starting with, and diminishing rapidly from the fifth harmonic, and virtually disappearing by the nineteenth harmonic.

Note The generic limits for harmonics for soft-starters which operate with a power level greater than 1kW are under consideration. Until these have been defined, harmonic filters are not required for any SFE3 soft-starter.

4.7.4 Emissions - Radio Frequency (RF)

Radio frequency emissions are propagated in two ways:

Conduction along the leads supplying the soft-starter.

Radiation from the operating equipment.

They also have two sources:

Source 1: The high frequency currents associated with the control electronics (this includes the microprocessor)

Source 2: The action of the semiconductor devices forming the power switching elements located in the controller main circuits.

The radiation measurements made from operating versions of SFE3 soft-starters show levels lower than the allowed limits. Further, enclosures (or cubicles) of metallic construction provide additional shielding for SFE3 soft-starters mounted within them. The only radiated interference effect that might arise from a soft-starter would be if mobile telephones, walkie-talkies etc. were to be used in very close proximity to a unit which was operating with the enclosure door open. For this reason, any enclosure must display a label that brings the possibility of electromagnetic interference to the attention of the operator under these circumstances.

4.7.5 Emissions - Conducted

Conducted emissions are able to travel great distances and may cause interference to any neighbouring consumers connected to the common low-voltage supply network.

Allowable levels for conducted emissions generated by semiconductor motor controllers and starters are influenced by the nature of the low-voltage power distribution network. The determining factor is whether the source of power is,

either (a) A private supply with a single consumer whose Point of Common Coupling (PCC) is at a high or medium voltage transformer.

or, (b) A public low-voltage network with more than one consumer, where the individual PCC is made directly to the network itself.

The first type of supply is identified as "Industrial" and requires the use of soft-starters compliant with EN 60947-4-2 Table 14: 'Equipment Class A Emission Levels'.

The second type of supply is identified as "Residential" and requires the use of Equipment Class B Apparatus. SFE3 soft-starters are able to comply with either classification provided the appropriate action is taken. (Section 4.7.7 describes the strategies for attaining and maintaining compliance.)

4.7.6 Important Systems Information:

The specification limits for both equipment classes assume systems are earthed at the star-point of the supply transformer through low impedance connections.

Certain industries, particularly continuous process industries, employ distribution systems that operate either with an earth through a high impedance or without an earth at all. These systems may cause severe problems of operator safety when fitted with capacitive high frequency filters -such systems are not considered in this document.

In the case of an isolated or high impedance earthed system, seek advice from your supplier before fitting a capacitive high frequency filter to a SFE3 soft-starter. It is essential that the specifying authority, user or installer has a clear knowledge of the type of network to which the product is to be fitted before making decisions as to which EMC strategy to adopt.

As supplied, all SFE3 products comply with the conducted emissions requirements for Equipment class A soft starters as defined by EN 60947-4-2:1996 Table 14. However, the length and type of cable connecting the motor to the starter module materially affects the level of emissions generated, and can amplify them greatly. The standard also allows different levels of emissions depending on motor rated current, which also affects the need to fit filters. The EN 60947-4-2:1996 standard only requires consideration of steady-state conditions

for EMC purposes and expressly excludes varying conditions such as those during ramp-up and ramp-down. Therefore, closing a bypass contactor around the module during the run condition will remove the need for any high frequency filters. However, some of the features (protection, optimising etc.), which are active during the run state, are disabled when the bypass contactor is closed. Users need to assess the cost and merit of fitting a bypass contactor compared with the cost of a filter when it is required.

Finally, statistics show that the number of disturbances arising from soft-starters, operating in a very wide variety of applications and networks throughout the world, is insignificant. Where EMC disturbances occur, it is very unlikely that they can be genuinely attributed to a soft-starter.

4.7.7 Strategies in Attaining and Maintaining EMC Compliance

Where possible, minimise the effect of electrical interference by incorporating the strategies listed below.

- Locate the SFE3 soft-starter unit as close as reasonably possible to the motor terminal box in order to minimise cable length.
- Ensure that, within any enclosure, the control wiring does not run parallel to the power wiring. Where this is unavoidable, then maintain a 100 mm separation between control cables and power cables.
- Where possible, ensure that the control wiring crosses at right-angles to the power wiring; this reduces the cross-coupling between cables.
- Screen any cables carrying sensitive signals. The digital control inputs to a SFE3 are opto-isolated and do not normally require buffering (e.g. through a small relay) or screening. Compliance in residential environments (Equipment class B) can be achieved by one of two methods:

a) Bypassing the soft-starter with an AC1 rated contactor controlled by the programmable relay set to the 'top-of-ramp'. (The ramp-up and ramp-down features remain effective in this configuration)

b) By running the soft starter in phase loss only mode.

Where a special purpose system filter has been applied at the point of common coupling, additional filtering of individual drives is not necessary and may introduce undesirable effects due to resonance.

For the purposes of EMC, the connections between the SFE3 controller and motor are considered to be an extension of the enclosure and preferably should be contained within earthed metallic trucking or conduit. Armoured cable, providing it is correctly terminated, may be used although the EMC performance will be slightly inferior. Screened cable is not necessary.

An alternative method of achieving the residential environment EMC requirements is to insert a special purpose filter designed for use with variable-frequency drives. Care must be taken to ensure that the short-term current rating of the filter will allow for the starting currents experienced. If this method is adopted, it is essential that the motor/controller connections are kept within 10 metres.

All associated electrical and electronic equipment near to the controller complies with the emission and immunity requirements of the EMC Directive.

FD8416 ApplicationsData

Software 55 .11

Name

Start Pedestal % % Stop Pedestal %

Start Time S Soft Stop Time S

Current Limit Level * FLC Current Limit Time S

Optimise Rate Auto Pedestal Auto Jog

Auto End Start Auto 3MC Auto bypass Auto Stop

SoftStop Smoothing Low Volt SoftStop Auto ramp Auto End Stop

Notes

Name

Start Pedestal % % Stop Pedestal %

Start Time S Soft Stop Time S

Current Limit Level * FLC Current Limit Time S

Optimise Rate Auto Pedestal Auto Jog

Auto End Start Auto 3MC Auto bypass Auto Stop

SoftStop Smoothing Low Volt SoftStop Auto ramp Auto End Stop

Notes

Name

Start Pedestal % % Stop Pedestal %

Start Time S Soft Stop Time S

Current Limit Level * FLC Current Limit Time S

Optimise Rate Auto Pedestal Auto Jog

Auto End Start Auto 3MC Auto bypass Auto Stop

SoftStop Smoothing Low Volt SoftStop Auto ramp Auto End Stop

Notes

Name

Start Pedestal % % Stop Pedestal %

Start Time S Soft Stop Time S

Current Limit Level * FLC Current Limit Time S

Optimise Rate Auto Pedestal Auto Jog

Auto End Start Auto 3MC Auto bypass Auto Stop

SoftStop Smoothing Low Volt SoftStop Auto ramp Auto End Stop

Notes

Name

Start Pedestal % % Stop Pedestal %

Start Time S Soft Stop Time S

Current Limit Level * FLC Current Limit Time S

Optimise Rate Auto Pedestal Auto Jog

Auto End Start Auto 3MC Auto bypass Auto Stop

SoftStop Smoothing Low Volt SoftStop Auto ramp Auto End Stop

Notes

Name

Start Pedestal % % Stop Pedestal %

Start Time S Soft Stop Time S

Current Limit Level * FLC Current Limit Time S

Optimise Rate Auto Pedestal Auto Jog

Auto End Start Auto 3MC Auto bypass Auto Stop

SoftStop Smoothing Low Volt SoftStop Auto ramp Auto End Stop

Notes

Name

Start Pedestal % % Stop Pedestal %

Start Time S Soft Stop Time S

Current Limit Level * FLC Current Limit Time S

Optimise Rate Auto Pedestal Auto Jog

Auto End Start Auto 3MC Auto bypass Auto Stop

SoftStop Smoothing Low Volt SoftStop Auto ramp Auto End Stop

Notes

Name

Start Pedestal % % Stop Pedestal %

Start Time S Soft Stop Time S

Current Limit Level * FLC Current Limit Time S

Optimise Rate Auto Pedestal Auto Jog

Auto End Start Auto 3MC Auto bypass Auto Stop

SoftStop Smoothing Low Volt SoftStop Auto ramp Auto End Stop

Notes

Name

Start Pedestal % % Stop Pedestal %

Start Time S Soft Stop Time S

Current Limit Level * FLC Current Limit Time S

Optimise Rate Auto Pedestal Auto Jog

Auto End Start Auto 3MC Auto bypass Auto Stop

SoftStop Smoothing Low Volt SoftStop Auto ramp Auto End Stop

Notes

Name

Start Pedestal % % Stop Pedestal %

Start Time S Soft Stop Time S

Current Limit Level * FLC Current Limit Time S

Optimise Rate Auto Pedestal Auto Jog

Auto End Start Auto 3MC Auto bypass Auto Stop

SoftStop Smoothing Low Volt SoftStop Auto ramp Auto End Stop

Notes

Name

Start Pedestal % % Stop Pedestal %

Start Time S Soft Stop Time S

Current Limit Level * FLC Current Limit Time S

Optimise Rate Auto Pedestal Auto Jog

Auto End Start Auto 3MC Auto bypass Auto Stop

SoftStop Smoothing Low Volt SoftStop Auto ramp Auto End Stop

Notes

Name

Start Pedestal % % Stop Pedestal %

Start Time S Soft Stop Time S

Current Limit Level * FLC Current Limit Time S

Optimise Rate Auto Pedestal Auto Jog

Auto End Start Auto 3MC Auto bypass Auto Stop

SoftStop Smoothing Low Volt SoftStop Auto ramp Auto End Stop

Notes

Name

Start Pedestal % % **Stop Pedestal** %

Start Time S **Soft Stop Time** S

Current Limit Level * FLC **Current Limit Time** S

Optimise Rate Auto Pedestal Auto Jog

Auto End Start Auto 3MC Auto bypass Auto Stop

SoftStop Smoothing Low Volt SoftStop Auto ramp Auto End Stop

Notes

Name

Start Pedestal % % **Stop Pedestal** %

Start Time S **Soft Stop Time** S

Current Limit Level * FLC **Current Limit Time** S

Optimise Rate Auto Pedestal Auto Jog

Auto End Start Auto 3MC Auto bypass Auto Stop

SoftStop Smoothing Low Volt SoftStop Auto ramp Auto End Stop

Notes

FD8416 5MC Parameters

03 September 2003

Software 55 .11

Std	PN	Parameter Name	Default	Max	Min	Units	Type	Scaling
<input checked="" type="checkbox"/>	0	dummy parameter	0	255	0	none	Read Only	1
		Description	Hints					
		Dummy used for mapping unused bit parameters etc.						

Std	PN	Parameter Name	Default	Max	Min	Units	Type	Scaling
<input checked="" type="checkbox"/>	1	STATION NUMBER	1	32	1	none	Read/Write	1
		Description	Hints					
		This is the local Network ID of this card						

Std	PN	Parameter Name	Default	Max	Min	Units	Type	Scaling
<input checked="" type="checkbox"/>	2	COUNTRY	44	255	1	none	Read/Write	1
		Description	Hints					
		International telephone code for Country e.g. England = 44. This is used by keypads to decide on language to use.						

Std	PN	Parameter Name	Default	Max	Min	Units	Type	Scaling
<input checked="" type="checkbox"/>	3	SOFTWARE TYPE	55	5	5	none	Read Only	1
		Description	Hints					
		Generic Software type always 5 something.						

Std	PN	Parameter Name	Default	Max	Min	Units	Type	Scaling
<input checked="" type="checkbox"/>	4	SOFTWARE VERSION	11	255	0	none	Read Only	1
		Description	Hints					
		Basically an issue number for a particular software type.						

Std	PN	Parameter Name	Default	Max	Min	Units	Type	Scaling
<input checked="" type="checkbox"/>	5	PASSWORD	0	255	0	none	Read/Write	1
		Description	Hints					
		Used by keypad has no effect on the 5MC. Keypad see's 0 as no password set.						

Std	PN	Parameter Name	Default	Max	Min	Units	Type	Scaling
<input checked="" type="checkbox"/>	6	FIRING MODE	0	3	0	none	Read/Write	1
		Description	Hints					
		0 = normal Motor (outside delta or star) 1 = Delta (inside delta no optimising) 2 = Closed loop Phase control 3 = Open loop Phase control						

Std	PN	Parameter Name	Default	Max	Min	Units	Type	Scaling
<input checked="" type="checkbox"/>	7	PROTECTION MODE	192	192	0	none	Read/Write	1
		Description	Hints					
		Controls which trips are available. FULL (64) = Full protection with full volts after top of ramp FULL+OPTIMISE (192) = full protection + optimise START+BYPASS (128) = Protection during start then bypass PHASE LOSS ONLY (0) = I/p Phase loss detection only	Start and Optimise mode is forced to Full Protection for firing modes other than 0, in phase loss only after TOR bottom 12.5% current is ignored.					

FD8416 5MC Parameters

03 September 2003

Software 55 .11

Std	PN	Parameter Name	Default	Max	Min	Units	Type	Scaling
<input checked="" type="checkbox"/>	8	STATUS 1	1	255	0	flags	Read Only	1
Description		Hints						
no description								

Std	PN	Parameter Name	Default	Max	Min	Units	Type	Scaling
<input checked="" type="checkbox"/>	9	STATUS 2	0	99	1	flags	Read Only	1
Description		Hints						
no description								

Std	PN	Parameter Name	Default	Max	Min	Units	Type	Scaling
<input checked="" type="checkbox"/>	10	STATUS 3	0	255	0	flags	Read Only	1
Description		Hints						
no description								

Std	PN	Parameter Name	Default	Max	Min	Units	Type	Scaling
<input checked="" type="checkbox"/>	11	SOFT START PEDESTAL	20	60	10	%	Read/Write	1
Description		Hints						
Starting point of soft start as percentage of supply volts								

Std	PN	Parameter Name	Default	Max	Min	Units	Type	Scaling
<input checked="" type="checkbox"/>	12	SOFT START TIME	5	255	1	Secs	Read/Write	1
Description		Hints						
Soft start Period over which unit ramps voltage to motor		Normally start times are in the range 5-30 seconds, long ramptimes over 1minute are for special applications only. The start (without current limit) is purely a voltage ramp. For lightly loaded motors they will normally reach full speed before the end of a long ramp.						

Std	PN	Parameter Name	Default	Max	Min	Units	Type	Scaling
<input checked="" type="checkbox"/>	13	KICK PEDESTAL	75	90	60	%	Read/Write	1
Description		Hints						
short Kick of voltage at start of ramp to dislodge sticky load.								

Std	PN	Parameter Name	Default	Max	Min	Units	Type	Scaling
<input checked="" type="checkbox"/>	14	KICK TIME	25	40	10	cycles	Read/Write	1
Description		Hints						
Number of cycles for which kick is applied (if selected).								

Std	PN	Parameter Name	Default	Max	Min	Units	Type	Scaling
<input checked="" type="checkbox"/>	15	DWELL TIME	5	255	1	Secs	Read/Write	1
Description		Hints						
Period of time following soft start allowed for load to settle before optimising commences (if selected).								

FD8416 5MC Parameters

03 September 2003

Software 55 .11

Std	PN	Parameter Name	Default	Max	Min	Units	Type	Scaling
<input checked="" type="checkbox"/>	16	SOFT STOP PEDESTAL	10	60	10	%	Read/Write	1

Description

percentage of supply voltage at which the soft stop will cease. The actual value is affected by certain load variations.

Hints

Std	PN	Parameter Name	Default	Max	Min	Units	Type	Scaling
<input checked="" type="checkbox"/>	17	SOFT STOP TIME	0	255	0	Secs	Read/Write	1

Description

period over which the soft stop ramp is performed.

Hints

Std	PN	Parameter Name	Default	Max	Min	Units	Type	Scaling
<input checked="" type="checkbox"/>	18	Auto Config	6	255	0	flags	Read/Write	1

Description

no description

Hints

Std	PN	Parameter Name	Default	Max	Min	Units	Type	Scaling
<input checked="" type="checkbox"/>	19	OPTIMISE RATE	5	30	4	none	Read/Write	1

Description

speed at which the 5MC will drop back the voltage during optimising. Some unstable loads benefit from a slower optimising rate.

Hints

Std	PN	Parameter Name	Default	Max	Min	Units	Type	Scaling
<input checked="" type="checkbox"/>	20	REFERENCE PF	146.763	146.763	0	degrees	Read Only	0.57554

Description

Power factor which the 5MC has calculated as the target for the optimising control loop.

Hints

Std	PN	Parameter Name	Default	Max	Min	Units	Type	Scaling
<input checked="" type="checkbox"/>	21	PRESENT PF	146.763	146.763	0	degrees	Read Only	0.57554

Description

The power factor of the load now.

Hints

Std	PN	Parameter Name	Default	Max	Min	Units	Type	Scaling
<input checked="" type="checkbox"/>	22	FIRING DELAY ANGLE	146.763	146.763	0	degrees	Read Only	0.57554

Description

The firing delay angle (thyristor off time).

Hints

Std	PN	Parameter Name	Default	Max	Min	Units	Type	Scaling
<input checked="" type="checkbox"/>	23	MAXIMUM OPTIMISING DELAY AN	57.554	146.763	17.2662	degrees	Read Only	0.57554

Description

Max allowed firing delay angle during optimising.

Hints

FD8416 5MC Parameters

03 September 2003

Software 55 .11

Std	PN	Parameter Name	Default	Max	Min	Units	Type	Scaling
-----	----	----------------	---------	-----	-----	-------	------	---------

<input checked="" type="checkbox"/>	24	RATED CURRENT(HUNDREDS)	0	3000	0	Amps	Read/Write	100
-------------------------------------	----	--------------------------	---	------	---	------	------------	-----

Description

Units rated current is stored in two bytes parameter 24 & 25, Parameter 24 holds the number of hundreds. These parameters should not be changed since they go hand in hand with the burden resistors fitted to the board.

Hints

Std	PN	Parameter Name	Default	Max	Min	Units	Type	Scaling
-----	----	----------------	---------	-----	-----	-------	------	---------

<input checked="" type="checkbox"/>	25	RATED CURRENT AMPS	5	99	1	Amps	Read/Write	1
-------------------------------------	----	--------------------	---	----	---	------	------------	---

Description

Units rated current is stored in two bytes parameter 24 & 25, Parameter 25 holds the number of units. These parameters should not be changed since they go hand in hand with the burden resistors fitted to the board.

Hints

Std	PN	Parameter Name	Default	Max	Min	Units	Type	Scaling
-----	----	----------------	---------	-----	-----	-------	------	---------

<input checked="" type="checkbox"/>	26	RUNNING CURRENT	0	7.96875	0	Amps	Read Only	0.03125
-------------------------------------	----	-----------------	---	---------	---	------	-----------	---------

Description

This is the current that the motor is taking, as monitored in one phase. This is the source parameter for the overload, current limit, shearpin, under current trip etc. The divisor is 32 and the multiplier is the rated current of the unit.

Hints

Std	PN	Parameter Name	Default	Max	Min	Units	Type	Scaling
-----	----	----------------	---------	-----	-----	-------	------	---------

<input checked="" type="checkbox"/>	27	PEAK START CURRENT	0	255	0	Amps	Read Only	1
-------------------------------------	----	--------------------	---	-----	---	------	-----------	---

Description

This is the peak current seen by the unit during the last start. Scaling is as per the running current

Hints

Std	PN	Parameter Name	Default	Max	Min	Units	Type	Scaling
-----	----	----------------	---------	-----	-----	-------	------	---------

<input checked="" type="checkbox"/>	28	LOW CURRENT LEVEL	0.09375	0.78125	0.03125	x Ie	Read/Write	0.03125
-------------------------------------	----	-------------------	---------	---------	---------	------	------------	---------

Description

This parameter if enabled sets a level of current under which the unit will trip. The level is not active during the starting or stopping phases.

Hints

The low current level flag is continually updated even if tripping is disabled.

Std	PN	Parameter Name	Default	Max	Min	Units	Type	Scaling
-----	----	----------------	---------	-----	-----	-------	------	---------

<input checked="" type="checkbox"/>	29	LOW CURRENT TIME	50	255	5	cycles	Read/Write	1
-------------------------------------	----	------------------	----	-----	---	--------	------------	---

Description

The number of cycles for which an under current situation must exist before tripping.

Hints

Std	PN	Parameter Name	Default	Max	Min	Units	Type	Scaling
-----	----	----------------	---------	-----	-----	-------	------	---------

<input checked="" type="checkbox"/>	30	CURRENT LIMIT LEVEL	3.5	7.96875	1	x Ie	Read/Write	0.03125
-------------------------------------	----	---------------------	-----	---------	---	------	------------	---------

Description

Level at which the the softs start ramp will be held.

Hints

The current limit only holds the ramp if it's level is reached. The current naturally falls as motor speed increases allowing the ramp to continue.

FD8416 5MC Parameters

03 September 2003

Software 55 .11

Std	PN	Parameter Name	Default	Max	Min	Units	Type	Scaling
-----	----	----------------	---------	-----	-----	-------	------	---------

<input checked="" type="checkbox"/>	31	CURRENT LIMIT TIME	30	255	5	Secs	Read/Write	1
-------------------------------------	----	--------------------	----	-----	---	------	------------	---

Description

The maximum time allowed for the current limit before it trips or continues the ramp regardless of motor current level.

Hints

Std	PN	Parameter Name	Default	Max	Min	Units	Type	Scaling
-----	----	----------------	---------	-----	-----	-------	------	---------

<input checked="" type="checkbox"/>	32	SHEARPIN LEVEL	3.125	5	1	x Ie	Read/Write	0.03125
-------------------------------------	----	----------------	-------	---	---	------	------------	---------

Description

Level of current which will cause a quick trip. Not active during start or stop.

Hints

Std	PN	Parameter Name	Default	Max	Min	Units	Type	Scaling
-----	----	----------------	---------	-----	-----	-------	------	---------

<input checked="" type="checkbox"/>	33	SHEARPIN TIME	100	255	5	cycles	Read/Write	1
-------------------------------------	----	---------------	-----	-----	---	--------	------------	---

Description

Number of cycles a Shearpin current must be present before tripping.

Hints

The shearpin is only active during the running phase not start or stop. The shearpin flag is updated even if tripping is not enabled.

Std	PN	Parameter Name	Default	Max	Min	Units	Type	Scaling
-----	----	----------------	---------	-----	-----	-------	------	---------

<input checked="" type="checkbox"/>	34	START OF OVERLOAD LEVEL	1.09375	2	0.59375	x Ie	Read/Write	0.03125
-------------------------------------	----	-------------------------	---------	---	---------	------	------------	---------

Description

Level at which the on board single phase overload starts to integrate.

Hints

This Overload does NOT replace an overload for the motor. The overload is designed to detect Soft start overloads.

Std	PN	Parameter Name	Default	Max	Min	Units	Type	Scaling
-----	----	----------------	---------	-----	-----	-------	------	---------

<input checked="" type="checkbox"/>	35	OVERLOAD DELAY	140	140	10	none	Read/Write	1
-------------------------------------	----	----------------	-----	-----	----	------	------------	---

Description

Arbitrary delay to slow overload integration down.

Hints

The overload delay mapping is designed for primarily for protection of the thyrisors.

Std	PN	Parameter Name	Default	Max	Min	Units	Type	Scaling
-----	----	----------------	---------	-----	-----	-------	------	---------

<input checked="" type="checkbox"/>	36	% OVERLOAD	0	100	0	%	Read Only	0.39216
-------------------------------------	----	------------	---	-----	---	---	-----------	---------

Description

Status value showing how close the overload is to tripping. (100 = tripped)

Hints

Std	PN	Parameter Name	Default	Max	Min	Units	Type	Scaling
-----	----	----------------	---------	-----	-----	-------	------	---------

<input checked="" type="checkbox"/>	37	CHASSIS TEMPERATURE	0	255	0	none	Read Only	1
-------------------------------------	----	---------------------	---	-----	---	------	-----------	---

Description

This parameter indicates the heatsink temperature when used with a suitable sensor.

Hints

Presently (00/06/20) the 5MC uses a thermal switch so the values shown are 0 or 255.

Std	PN	Parameter Name	Default	Max	Min	Units	Type	Scaling
-----	----	----------------	---------	-----	-----	-------	------	---------

<input type="checkbox"/>	38	POT1	0	255	0	none	Read Only	1
--------------------------	----	------	---	-----	---	------	-----------	---

Description

This parameter is normally mapped to start time.

Hints

Now only used on special edition boards.

FD8416 5MC Parameters

03 September 2003

Software 55 .11

Std	PN	Parameter Name	Default	Max	Min	Units	Type	Scaling
<input type="checkbox"/>	39	POT2	0	255	0	none	Read Only	1
Description		Hints						
This parameter is normally mapped to stop time.		Now only used on special edition boards						

Std	PN	Parameter Name	Default	Max	Min	Units	Type	Scaling
<input type="checkbox"/>	40	POT3	0	1	0	none	Read Only	1
Description		Hints						
This parameter is normally mapped to current limit level..		Now only used on special edition boards						

Std	PN	Parameter Name	Default	Max	Min	Units	Type	Scaling
<input type="checkbox"/>	41	DC I/P	0	255	0	Volts	Read Only	1
Description		Hints						
0-10V input for load monitoring or phase angle setpoint etc. (can be adjusted to max scale 21V)								

Std	PN	Parameter Name	Default	Max	Min	Units	Type	Scaling
<input type="checkbox"/>	42	Thermistor	0	255	0	none	Read Only	1
Description		Hints						
Monitors the Thermistor I/p (for use with standard motor thermistors). The values are not all that useful as thermistors act much like a switch.								

Std	PN	Parameter Name	Default	Max	Min	Units	Type	Scaling
<input type="checkbox"/>	43	4-20mA i/p	0	255	0	mA	Read Only	1
Description		Hints						
Monitors the 4 to 20mA input. Note this input is referenced to the PCB 0V and so cannot be used to daisy chained sensors.								

Std	PN	Parameter Name	Default	Max	Min	Units	Type	Scaling
<input checked="" type="checkbox"/>	44	TEMP TRIP LEVEL	30	255	20	none	Read/Write	1
Description		Hints						
The value at which parameter 37 causes a trip								

Std	PN	Parameter Name	Default	Max	Min	Units	Type	Scaling
<input type="checkbox"/>	45	4-20MA MAP	0	125	0	prmr	Read/Write	1
Description		Hints						
Value is parameter to which the 4-20mA data will be sent.								

Std	PN	Parameter Name	Default	Max	Min	Units	Type	Scaling
<input type="checkbox"/>	46	4-20MA SET LEVEL	10.24	20.32	0.08	mA	Read/Write	0.08
Description		Hints						
value is level at which the 4-20mA level bit will be set.								

Std	PN	Parameter Name	Default	Max	Min	Units	Type	Scaling
<input type="checkbox"/>	47	DC INPUT MAP	0	125	0	prmr	Read/Write	1
Description		Hints						
Value is parameter to which the DC input data will be sent.								

FD8416 5MC Parameters

03 September 2003

Software 55 .11

Std	PN	Parameter Name	Default	Max	Min	Units	Type	Scaling
<input type="checkbox"/>	48	SET LEVEL DC I/P	5.01961	9.96078	0.03922	Volts	Read/Write	0.03922
Description		Hints						
value is level at which the DC-I/p level bit will be set.								

Std	PN	Parameter Name	Default	Max	Min	Units	Type	Scaling
<input type="checkbox"/>	49	MAP DAC O/P 1	26	125	0	pmtr	Read/Write	1
Description		Hints						
The value is the parameter number which will be the source for DAC 1.		Dac 1 normally displays running current as 0-10V						

Std	PN	Parameter Name	Default	Max	Min	Units	Type	Scaling
<input type="checkbox"/>	50	MAP DAC O/P 2	22	125	0	pmtr	Read/Write	1
Description		Hints						
The value is the parameter number which will be the source for DAC 2.		Dac 2 normally displays delay angle as 0-10V						

Std	PN	Parameter Name	Default	Max	Min	Units	Type	Scaling
<input checked="" type="checkbox"/>	51	USER FLAGS 1	142	255	0	flags	Read/Write	1
Description		Hints						
More system status flags								

Std	PN	Parameter Name	Default	Max	Min	Units	Type	Scaling
<input checked="" type="checkbox"/>	52	USER FLAGS 2	0	255	0	flags	Read/Write	1
Description		Hints						
Even more status flags , This flag must be 0 when parameters are saved.								

Std	PN	Parameter Name	Default	Max	Min	Units	Type	Scaling
<input checked="" type="checkbox"/>	53	USER FLAGS 3	51	255	0	flags	Read/Write	1
Description		Hints						
no description								

Std	PN	Parameter Name	Default	Max	Min	Units	Type	Scaling
<input checked="" type="checkbox"/>	54	I/O POLARITY	127	255	0	flags	Read/Write	1
Description		Hints						
sets the I/o polarity, for Led,K1-4 and I/p1-3 That is 1 to 1 or 1 to 0.								

Std	PN	Parameter Name	Default	Max	Min	Units	Type	Scaling
<input type="checkbox"/>	55	MAP LED	9	255	0	x le	Read/Write	1
Description		Hints						
Value is the source parameter of th LED bit (pots & Switchs board only)								

Std	PN	Parameter Name	Default	Max	Min	Units	Type	Scaling
<input type="checkbox"/>	56	LED MASK	1	255	0	x le	Read/Write	1
Description		Hints						
bit mask for Led source (pots & Switchs board only)								

FD8416 5MC Parameters

03 September 2003

Software 55 .11

Std	PN	Parameter Name	Default	Max	Min	Units	Type	Scaling
<input checked="" type="checkbox"/>	57	MAP K1 TO	52	125	0	pmtr	Read/Write	1

Description

Value is parameter number which is the Source for the K1 bit.
Parameter 58 holds the mask for mapping to

Hints

Std	PN	Parameter Name	Default	Max	Min	Units	Type	Scaling
<input checked="" type="checkbox"/>	58	K1 BIT MASK	32	255	0	mask	Read/Write	1

Description

Parameter 58 holds the mask for mapping K1 From.

Hints

Std	PN	Parameter Name	Default	Max	Min	Units	Type	Scaling
<input checked="" type="checkbox"/>	59	MAP k2 TO	8	125	0	pmtr	Read/Write	1

Description

Value is parameter number which is the Source for the K2 bit.
Parameter 60 holds the mask for mapping K2 to.

Hints

Std	PN	Parameter Name	Default	Max	Min	Units	Type	Scaling
<input checked="" type="checkbox"/>	60	K2 BIT MASK	8	128	0	mask	Read/Write	1

Description

Parameter 60 holds the mask for mapping K2 From.

Hints

Std	PN	Parameter Name	Default	Max	Min	Units	Type	Scaling
<input type="checkbox"/>	61	MAP K3 TO	9	125	0	pmtr	Read/Write	1

Description

Value is parameter number which is theSource for the K3 bit.
Parameter 61 holds th mask for mapping K3 to

Hints

Std	PN	Parameter Name	Default	Max	Min	Units	Type	Scaling
<input type="checkbox"/>	62	K3 BIT MASK	1	3	0	mask	Read/Write	1

Description

Parameter 63 holds the mask for mapping K3 From.

Hints

Std	PN	Parameter Name	Default	Max	Min	Units	Type	Scaling
<input type="checkbox"/>	63	MAP K4 TO	9	125	0	pmtr	Read/Write	1

Description

Value is parameter number which is theSource for the K4 bit.
Parameter 64 holds th mask for mapping K4 to.

Hints

Std	PN	Parameter Name	Default	Max	Min	Units	Type	Scaling
<input type="checkbox"/>	64	K4 BIT MASK	2	3	0	mask	Read/Write	1

Description

Parameter 64 holds the mask for mapping K4 From.

Hints

FD8416 5MC Parameters

03 September 2003

Software 55 .11

Std	PN	Parameter Name	Default	Max	Min	Units	Type	Scaling
<input checked="" type="checkbox"/>	65	I/P1 MAP TO	52	125	0	pmtr	Read/Write	1

Description

Value is parameter number which is the destination for the I/p1 bit.
Parameter 66 holds the mask for mapping I/p1 into.

Hints

This is normally the start/stop I/p (remote).
It would be unusual for it to be anything else.

Std	PN	Parameter Name	Default	Max	Min	Units	Type	Scaling
<input checked="" type="checkbox"/>	66	I/P1 BIT MASK	16	128	0	mask	Read/Write	1

Description

Parameter 66 holds the mask for mapping I/p1 into.

Hints

Std	PN	Parameter Name	Default	Max	Min	Units	Type	Scaling
<input checked="" type="checkbox"/>	67	I/P2 MAP TO	0	125	0	pmtr	Read/Write	1

Description

Value is parameter number which is the destination for the I/p2 bit.
Parameter 68 holds the mask for mapping I/p2 into.

Hints

Std	PN	Parameter Name	Default	Max	Min	Units	Type	Scaling
<input checked="" type="checkbox"/>	68	I/P2 BIT MASK	0	128	0	mask	Read/Write	1

Description

Parameter 68 holds the mask for mapping I/p2 into.

Hints

Std	PN	Parameter Name	Default	Max	Min	Units	Type	Scaling
<input type="checkbox"/>	69	I/P3 MAP TO	0	125	0	pmtr	Read/Write	1

Description

Value is parameter number which is the destination for the I/p3 bit.
Parameter 70 holds the mask for mapping I/p3 into.

Hints

Std	PN	Parameter Name	Default	Max	Min	Units	Type	Scaling
<input type="checkbox"/>	70	I/P3 BIT MAP	0	128	0	mask	Read/Write	1

Description

Parameter 70 holds the mask for mapping I/p2 into.

Hints

Std	PN	Parameter Name	Default	Max	Min	Units	Type	Scaling
<input checked="" type="checkbox"/>	71	CONTACTOR DELAY	160	800	20	mS	Read/Write	4

Description

Following a start command this is the delay allowed for the main incoming contactor to close. After this time a phase loss detection routine checks for the incoming supply.

Hints

Std	PN	Parameter Name	Default	Max	Min	Units	Type	Scaling
<input checked="" type="checkbox"/>	72	TRIP SENSITIVITY	1	15	1	none	Read/Write	1

Description

An arbitrary number to adjust the sensitivity of some of the fault trips. The larger the number the slower the trip.

Hints

FD8416 5MC Parameters

03 September 2003

Software 55 .11

Std	PN	Parameter Name	Default	Max	Min	Units	Type	Scaling
-----	----	----------------	---------	-----	-----	-------	------	---------

<input checked="" type="checkbox"/>	73	LAST TRIP	0	15	1	trips	Read Only	1
-------------------------------------	----	-----------	---	----	---	-------	-----------	---

Description

the number of the last trip

Hints

- E1 Phase Loss
- E2 Too Hot
- E3,5,6 SCR Signal
- E4 SCR Firing
- E7,8,9 Sensing Signal
- E10 SCR Shorted
- E11 Low Current
- E12 C/L Time Out
- E13 Overload
- E14 Shearpin
- E15 Thermistor
- E16 External trip

Std	PN	Parameter Name	Default	Max	Min	Units	Type	Scaling
-----	----	----------------	---------	-----	-----	-------	------	---------

<input checked="" type="checkbox"/>	74	2ND LAST TRIP	0	15	1	trips	Read Only	1
-------------------------------------	----	---------------	---	----	---	-------	-----------	---

Description

the number of the 2nd to last trip

Hints

- E1 Phase Loss
- E2 Too Hot
- E3,5,6 SCR Signal
- E4 SCR Firing
- E7,8,9 Sensing Signal
- E10 SCR Shorted
- E11 Low Current
- E12 C/L Time Out
- E13 Overload
- E14 Shearpin
- E15 Thermistor
- E16 External trip

Std	PN	Parameter Name	Default	Max	Min	Units	Type	Scaling
-----	----	----------------	---------	-----	-----	-------	------	---------

<input checked="" type="checkbox"/>	75	3RD LAST TRIP	0	15	1	trips	Read Only	1
-------------------------------------	----	---------------	---	----	---	-------	-----------	---

Description

the number of the 3rd to last trip

Hints

- E1 Phase Loss
- E2 Too Hot
- E3,5,6 SCR Signal
- E4 SCR Firing
- E7,8,9 Sensing Signal
- E10 SCR Shorted
- E11 Low Current
- E12 C/L Time Out
- E13 Overload
- E14 Shearpin
- E15 Thermistor
- E16 External trip

FD8416 5MC Parameters

03 September 2003

Software 55 .11

Std	PN	Parameter Name	Default	Max	Min	Units	Type	Scaling
<input checked="" type="checkbox"/>	76	4TH LAST TRIP	0	15	1	trips	Read Only	1
Description			Hints					
the number of the 4th to last trip			E1 Phase Loss E2 Too Hot E3,5,6 SCR Signal E4 SCR Firing E7,8,9 Sensing Signal E10 SCR Shorted E11 Low Current E12 C/L Time Out E13 Overload E14 Shearpin E15 Thermistor E16 External trip					

Std	PN	Parameter Name	Default	Max	Min	Units	Type	Scaling
<input checked="" type="checkbox"/>	77	5TH LAST TRIP	0	15	1	trips	Read Only	1
Description			Hints					
the number of the 5th to last trip			E1 Phase Loss E2 Too Hot E3,5,6 SCR Signal E4 SCR Firing E7,8,9 Sensing Signal E10 SCR Shorted E11 Low Current E12 C/L Time Out E13 Overload E14 Shearpin E15 Thermistor E16 External trip					

Std	PN	Parameter Name	Default	Max	Min	Units	Type	Scaling
<input checked="" type="checkbox"/>	78	PROTECTION MODE 2	192	192	0	none	Read/Write	1
Description			Hints					
Protection mode to use with second parameter set Controls which trips are available. FULL (64) = Full protection with full volts after top of ramp FULL+OPTIMISE (192) = full protection + optimise START+BYPASS (128) = Protection during start then bypass PHASE LOSS ONLY (0) = I/p Phase loss detection only			Edit in P Menu					

Std	PN	Parameter Name	Default	Max	Min	Units	Type	Scaling
<input checked="" type="checkbox"/>	79	START PED 2	50	60	10	%	Read/Write	1
Description			Hints					
start pedestal to use with 2nd parameter set			Edit in P Menu					

Std	PN	Parameter Name	Default	Max	Min	Units	Type	Scaling
<input checked="" type="checkbox"/>	80	START TIME 2	5	255	1	Secs	Read/Write	1
Description			Hints					
Start time to use with the second parameter set			Edit in P Menu					

FD8416 5MC Parameters

03 September 2003

Software 55 .11

Std	PN	Parameter Name	Default	Max	Min	Units	Type	Scaling
<input checked="" type="checkbox"/>	81	KICK PED 2	75	90	60	%	Read/Write	1
Description		Hints						
kickstart pedestal to use with the second parameter set		Edit in P Menu						

Std	PN	Parameter Name	Default	Max	Min	Units	Type	Scaling
<input checked="" type="checkbox"/>	82	KICK TIME 2	25	40	10	cycles	Read/Write	1
Description		Hints						
kickstart time to use with the second parameter set		Edit in P Menu						

Std	PN	Parameter Name	Default	Max	Min	Units	Type	Scaling
<input checked="" type="checkbox"/>	83	DWELL 2	5	255	1	Secs	Read/Write	1
Description		Hints						
Dwell time to use with the second parameter set.		Edit in P Menu						

Std	PN	Parameter Name	Default	Max	Min	Units	Type	Scaling
<input checked="" type="checkbox"/>	84	STOP PED 2	10	60	10	%	Read/Write	1
Description		Hints						
Stop pedestal to use with the second parameter set		Edit in P Menu						

Std	PN	Parameter Name	Default	Max	Min	Units	Type	Scaling
<input checked="" type="checkbox"/>	85	STOP TIME 2	0	255	0	Secs	Read/Write	1
Description		Hints						
Stop time to use with the second parameter set.		Edit in P Menu						

Std	PN	Parameter Name	Default	Max	Min	Units	Type	Scaling
<input checked="" type="checkbox"/>	86	Auto Config 2	6	255	0	flags	Read/Write	1
Description		Hints						
Auto configuration flags to use with the second parameter set.		Edit in P Menu						

Std	PN	Parameter Name	Default	Max	Min	Units	Type	Scaling
<input checked="" type="checkbox"/>	87	UNDER CURRENT 2	0.125	1	0	x Ie	Read/Write	0.03125
Description		Hints						
Under current level to use with the second parameter set.		Edit in P Menu						

Std	PN	Parameter Name	Default	Max	Min	Units	Type	Scaling
<input checked="" type="checkbox"/>	88	UNDER CURRENT TIME 2	50	255	5	cycles	Read/Write	1
Description		Hints						
Under Current time to use with the second parameter set		Edit in P Menu						

Std	PN	Parameter Name	Default	Max	Min	Units	Type	Scaling
<input checked="" type="checkbox"/>	89	CURRENT LIMIT 2	4	7.96875	1	x Ie	Read/Write	0.03125
Description		Hints						
Current limit value to be used with the second parameter set.		Edit in P Menu						

FD8416 5MC Parameters

03 September 2003

Software 55 .11

Std	PN	Parameter Name	Default	Max	Min	Units	Type	Scaling
-----	----	----------------	---------	-----	-----	-------	------	---------

<input checked="" type="checkbox"/>	90	CURRENT LIMIT TIME 2	15	255	5	Secs	Read/Write	1
-------------------------------------	----	----------------------	----	-----	---	------	------------	---

Description

Hints

Current limit timeout to use with the second parameter set Edit in P Menu

Std	PN	Parameter Name	Default	Max	Min	Units	Type	Scaling
-----	----	----------------	---------	-----	-----	-------	------	---------

<input checked="" type="checkbox"/>	91	SHEARPIN 2	3	5	1	x le	Read/Write	0.03125
-------------------------------------	----	------------	---	---	---	------	------------	---------

Description

Hints

Shearpin Level to use with the second parameter set Edit in P Menu

Std	PN	Parameter Name	Default	Max	Min	Units	Type	Scaling
-----	----	----------------	---------	-----	-----	-------	------	---------

<input checked="" type="checkbox"/>	92	SHEARPIN TIME 2	50	255	5	cycles	Read/Write	1
-------------------------------------	----	-----------------	----	-----	---	--------	------------	---

Description

Hints

Shearpin Time to use with the second parameter set. Edit in P Menu

Std	PN	Parameter Name	Default	Max	Min	Units	Type	Scaling
-----	----	----------------	---------	-----	-----	-------	------	---------

<input checked="" type="checkbox"/>	93	OVERLOAD LEVEL 2	1.09375	2	0.5	x le	Read/Write	0.03125
-------------------------------------	----	------------------	---------	---	-----	------	------------	---------

Description

Hints

Overload Level to use with the second parameter set Edit in P Menu

Std	PN	Parameter Name	Default	Max	Min	Units	Type	Scaling
-----	----	----------------	---------	-----	-----	-------	------	---------

<input checked="" type="checkbox"/>	94	OVERLOAD DELAY 2	140	140	10	none	Read/Write	1
-------------------------------------	----	------------------	-----	-----	----	------	------------	---

Description

Hints

Overload delay to use with the second parameter set Edit in P Menu

Std	PN	Parameter Name	Default	Max	Min	Units	Type	Scaling
-----	----	----------------	---------	-----	-----	-------	------	---------

<input checked="" type="checkbox"/>	95	USER FLAGS 1,2	134	255	0	flags	Read/Write	1
-------------------------------------	----	----------------	-----	-----	---	-------	------------	---

Description

Hints

User flags 1 to use with secondary parameter set. Edit in P Menu

Std	PN	Parameter Name	Default	Max	Min	Units	Type	Scaling
-----	----	----------------	---------	-----	-----	-------	------	---------

<input checked="" type="checkbox"/>	96	USER FLAGS 2,2	64	255	0	flags	Read/Write	1
-------------------------------------	----	----------------	----	-----	---	-------	------------	---

Description

Hints

user flags 2 to use with the secondary parameter set. Edit in P Menu

Std	PN	Parameter Name	Default	Max	Min	Units	Type	Scaling
-----	----	----------------	---------	-----	-----	-------	------	---------

<input checked="" type="checkbox"/>	97	ipf1_addr	0	125	0	prmr	Read/Write	1
-------------------------------------	----	-----------	---	-----	---	------	------------	---

Description

Hints

User flag mapping through parameters 97,98,99,100.
 97,98 give source flag address
 97=parameter 98 = bit mask
 99,100 give the destination flag address.
 99=parameter 100 = bit mask

Edit in P Menu

FD8416 5MC Parameters

03 September 2003

Software 55 .11

Std	PN	Parameter Name	Default	Max	Min	Units	Type	Scaling
<input checked="" type="checkbox"/>	98	ipf1_mask	0	128	0	mask	Read/Write	1

Description

User flag mapping through parameters 97,98,99,100.
 97,98 give source flag address
 97=parameter 98 = bit mask
 99,100 give the destination flag address.
 99=parameter 100 = bit mask

Hints

Std	PN	Parameter Name	Default	Max	Min	Units	Type	Scaling
<input checked="" type="checkbox"/>	99	opf1_addr	0	125	0	pmtr	Read/Write	1

Description

User flag mapping through parameters 97,98,99,100.
 97,98 give source flag address
 97=parameter 98 = bit mask
 99,100 give the destination flag address.
 99=parameter 100 = bit mask

Hints

Std	PN	Parameter Name	Default	Max	Min	Units	Type	Scaling
<input checked="" type="checkbox"/>	100	opf1_mask	0	255	0	mask	Read/Write	1

Description

User flag mapping through parameters 97,98,99,100.
 97,98 give source flag address
 97=parameter 98 = bit mask
 99,100 give the destination flag address.
 99=parameter 100 = bit mask

Hints

Std	PN	Parameter Name	Default	Max	Min	Units	Type	Scaling
<input checked="" type="checkbox"/>	101	ipf2_addr	0	125	0	pmtr	Read/Write	1

Description

User flag mapping through parameters 101,102,103,104.
 101,102 give source flag address
 101=parameter 102 = bit mask
 103,104 give the destination flag address.
 103=parameter 104 = bit mask

Hints

Std	PN	Parameter Name	Default	Max	Min	Units	Type	Scaling
<input checked="" type="checkbox"/>	102	ipf2_mask	0	20	0	mask	Read/Write	1

Description

User flag mapping through parameters 101,102,103,104.
 101,102 give source flag address
 101=parameter 102 = bit mask
 103,104 give the destination flag address.
 103=parameter 104 = bit mask

Hints

Std	PN	Parameter Name	Default	Max	Min	Units	Type	Scaling
<input checked="" type="checkbox"/>	103	opf2_addr	0	125	0	pmtr	Read/Write	1

Description

User flag mapping through parameters 101,102,103,104.
 101,102 give source flag address
 101=parameter 102 = bit mask
 103,104 give the destination flag address.
 103=parameter 104 = bit mask

Hints

FD8416 5MC Parameters

03 September 2003

Software 55 .11

Std	PN	Parameter Name	Default	Max	Min	Units	Type	Scaling
<input checked="" type="checkbox"/>	104	opf2_mask	0	11	0	mask	Read/Write	1

Description

User flag mapping through parameters 101,102,103,104.
101,102 give source flag address
101=parameter 102 = bit mask
103,104 give the destination flag address.
103=parameter 104 = bit mask

Hints

Std	PN	Parameter Name	Default	Max	Min	Units	Type	Scaling
<input checked="" type="checkbox"/>	105	loop_input	41	125	0	pmtr	Read/Write	1

Description

The value is the number of the parameter which will be the source for control loop setpoint.

Hints

Std	PN	Parameter Name	Default	Max	Min	Units	Type	Scaling
<input checked="" type="checkbox"/>	106	loop_feedback	26	125	0	pmtr	Read/Write	1

Description

The value is the number of the parameter which will be the source for control loop feedback.

Hints

Std	PN	Parameter Name	Default	Max	Min	Units	Type	Scaling
<input checked="" type="checkbox"/>	107	error_gain	37	255	1	none	Read/Write	1

Description

Multiplier for the loop error signal.

Hints

Std	PN	Parameter Name	Default	Max	Min	Units	Type	Scaling
<input checked="" type="checkbox"/>	108	error_div	7	255	1	none	Read/Write	1

Description

divisor for the loop error signal

Hints

Std	PN	Parameter Name	Default	Max	Min	Units	Type	Scaling
<input checked="" type="checkbox"/>	109	max_slope	10	50	0	none	Read/Write	1

Description

The maximum allowed single error in open loop.

Hints

Std	PN	Parameter Name	Default	Max	Min	Units	Type	Scaling
<input checked="" type="checkbox"/>	110	guard_gap	10	150	0	none	Read/Write	1

Description

The minimum allowed firing delay in both open loop and pahse control modes. This allows for jitter and power factor of the load.

Hints

Std	PN	Parameter Name	Default	Max	Min	Units	Type	Scaling
<input checked="" type="checkbox"/>	111	user parameter	0	255	0	none	Read/Write	1

Description

This parameter may be set by the user via the serial link.

Hints

FD8416 5MC Parameters

03 September 2003

Software 55 .11

Std	PN	Parameter Name	Default	Max	Min	Units	Type	Scaling
<input checked="" type="checkbox"/>	112	STATUS 4	0	255	0	flags	Read Only	1
Description		Hints						
More useful control flags								

Std	PN	Parameter Name	Default	Max	Min	Units	Type	Scaling
<input type="checkbox"/>	113	drive type	0	255	0	none	Read Only	1
Description		Hints						
Unused								

Std	PN	Parameter Name	Default	Max	Min	Units	Type	Scaling
<input checked="" type="checkbox"/>	114	Soft Switch Off	0	5	0	none	Read/Write	1
Description		Hints						
System Variable								

Std	PN	Parameter Name	Default	Max	Min	Units	Type	Scaling
<input checked="" type="checkbox"/>	115	selected app	0	9	0	none	Read/Write	1
Description		Hints						
Value selected from application table. Not implemented on some versions of software.								

Std	PN	Parameter Name	Default	Max	Min	Units	Type	Scaling
<input checked="" type="checkbox"/>	116	5mc inhibit time	0	63.75	0	Minutes	Read/Write	0.25
Description		Hints						
time for which the unit is not allowed to restart. Mainly for larger stacks to avoid destroying thyristors during commissioning. Value depends on Unit size.								

Std	PN	Parameter Name	Default	Max	Min	Units	Type	Scaling
<input type="checkbox"/>	117	command source	0	3	0	none	Read/Write	1
Description		Hints						
Unused								

Std	PN	Parameter Name	Default	Max	Min	Units	Type	Scaling
<input checked="" type="checkbox"/>	118	Motor Rated Current	0	32	16	Amps	Read/Write	1
Description		Hints						
Motor Rated Current used when motor current is lower than starter rated current		50-100% of softstart rating used in application setups						

Std	PN	Parameter Name	Default	Max	Min	Units	Type	Scaling
<input type="checkbox"/>	119	default pnu to display	26	125	0	none	Read/Write	1
Description		Hints						
Unused								

Std	PN	Parameter Name	Default	Max	Min	Units	Type	Scaling
<input checked="" type="checkbox"/>	120	STATUS 5	0	255	0	flags	Read Only	1
Description		Hints						
Yet more status flags								

FD8416 5MC Parameters

03 September 2003

Software 55 .11

Std	PN	Parameter Name	Default	Max	Min	Units	Type	Scaling
-----	----	----------------	---------	-----	-----	-------	------	---------

<input checked="" type="checkbox"/>	121	USER_FLAGS4	0	255	1	flags	Read/Write	1
-------------------------------------	-----	-------------	---	-----	---	-------	------------	---

Description

Hints

Yet more control flags

Std	PN	Parameter Name	Default	Max	Min	Units	Type	Scaling
-----	----	----------------	---------	-----	-----	-------	------	---------

<input checked="" type="checkbox"/>	122	ss_smoothing	5	15	1	none	Read/Write	1
-------------------------------------	-----	--------------	---	----	---	------	------------	---

Description

Hints

Arbitrary filter to smooth soft stop jitters caused by unstable load.

Std	PN	Parameter Name	Default	Max	Min	Units	Type	Scaling
-----	----	----------------	---------	-----	-----	-------	------	---------

<input checked="" type="checkbox"/>	123	Temp/Alt Derate	0	50	0	%	Read/Write	1
-------------------------------------	-----	-----------------	---	----	---	---	------------	---

Description

Hints

Reduce certain parameters (current limit etc.) by this % for high temperature or altitude, Set derate then load an application, this would then be derated.

The derate is only applied as an application is loaded.

Std	PN	Parameter Name	Default	Max	Min	Units	Type	Scaling
-----	----	----------------	---------	-----	-----	-------	------	---------

<input type="checkbox"/>	124	OffLineCommand	0	255	0	none	Read/Write W	1
--------------------------	-----	----------------	---	-----	---	------	--------------	---

Description

Hints

Certain system functions are carried out by writing to this register. See the command table

1=Disable 2=Enable 3=BusStarting
4=RemoteStarting 5=ResetStarter
6=ResetTrip 7= BusStart 8= BusStop
9=Load Eerom From Defaults 10= Load
Ram From Eerom 11= Save Ram to Eerom

Std	PN	Parameter Name	Default	Max	Min	Units	Type	Scaling
-----	----	----------------	---------	-----	-----	-------	------	---------

<input type="checkbox"/>	125	Bus BaudRate	0	255	0	none	Read/Write	1
--------------------------	-----	--------------	---	-----	---	------	------------	---

Description

Hints

0 = 9600 baud non zero = 15625 baud

Only Active With certain Comms Options

Std	PN	Parameter Name	Default	Max	Min	Units	Type	Scaling
-----	----	----------------	---------	-----	-----	-------	------	---------

<input type="checkbox"/>	126	Bus Action on Fail	0	255	0	none	Read/Write	1
--------------------------	-----	--------------------	---	-----	---	------	------------	---

Description

Hints

Action following a bus failure 0= no trip 1 = trip

Only Active With certain Comms Options

Std	PN	Parameter Name	Default	Max	Min	Units	Type	Scaling
-----	----	----------------	---------	-----	-----	-------	------	---------

<input type="checkbox"/>	127	Hidden Trip Flags	0	255	0	flags	Read/Write	1
--------------------------	-----	-------------------	---	-----	---	-------	------------	---

Description

Hints

Enable / disable certain trips

This Parameter is really for diagnostic purposes only!

Parameter Bitmask	8	<i>STATUS 1</i> Name	Type	Default = ON	Description
00000001	(1)	Stopped	Status	<input type="checkbox"/>	start/stop signal inactive thyristors off main contactor open
00000010	(2)	Starting	Status	<input type="checkbox"/>	Starter is in start ramp
00000100	(4)	Current Limit	Status	<input type="checkbox"/>	During a softstart indicates motor has reached Current limit level and ramp is being held.
00001000	(8)	Top Of Ramp	Status	<input type="checkbox"/>	The unit has finished the start ramp and any current limit
00010000	(16)	Dwell	Status	<input type="checkbox"/>	Period of time at the the end of the start ramp where the motor is held at full volts before entering optimising to allow the load to stabilise
00100000	(32)	Full Conduction	Status	<input type="checkbox"/>	Thyristors are fully on
01000000	(64)	Energy Saving	Status	<input type="checkbox"/>	Starter is monitoring the motor power factor and adjusting applied voltage to bring it close to optimum.
10000000	(128)	Stopping	Status	<input type="checkbox"/>	The starter is performing a stop ramp

Parameter Bitmask	9	<i>STATUS 2</i> Name	Type	Default = ON	Description
00000001	(1)	Alarm	Status	<input type="checkbox"/>	Starter has detected a fault and has tripped
00000010	(2)	Overload Integrating	Status	<input type="checkbox"/>	The on board overload has detected over current and is integrating
00000100	(4)	Stall	Status	<input type="checkbox"/>	The starter has detected that the motor speed is slipping
00001000	(8)	Forced Override	Status	<input type="checkbox"/>	The starter has turned off optimising since the current has risen above 80% FLC
00010000	(16)	Noise	Status	<input type="checkbox"/>	The starter is experiencing poor mains reference signals
00100000	(32)	Inhibit Start	Status	<input type="checkbox"/>	The start is inhibited for a period to keep the unit within its allowable start duty.
01000000	(64)	DC I/p level reached	Status	<input type="checkbox"/>	The DC I/p has risen above the level specified in parameter 48
10000000	(128)	4-20mA level reached	Status	<input type="checkbox"/>	The 4-20mA I/p has risen above the level specified in parameter 46

FD8416 5MC Bit Parameters

03 September 2003

Software 55 .11

Parameter Bitmask	10	<i>STATUS 3</i> Name	Type	Default = ON	Description
00000001	(1)	K1	Status	<input type="checkbox"/>	Status of relay K1
00000010	(2)	K2	Status	<input type="checkbox"/>	Status of relay K2
00000100	(4)	K3	Status	<input type="checkbox"/>	Status of relay K3 (QFE+)
00001000	(8)	K4	Status	<input type="checkbox"/>	Status of relay K4 (QFE+)
00010000	(16)	I/P 1	Status	<input type="checkbox"/>	Status of input 1
00100000	(32)	I/P 2	Status	<input type="checkbox"/>	Status of input 2 (QFE+)
01000000	(64)	I/P 3	Status	<input type="checkbox"/>	Status of input 3 (QFE+)
10000000	(128)	RED LED (unused)	Status	<input type="checkbox"/>	

Parameter Bitmask	18	<i>Auto Config</i> Name	Type	Default = ON	Description
00000001	(1)	Auto Ramp	read/write	<input type="checkbox"/>	Gently ramps the voltage to the starter acting a bit like an automatic current limit.
00000010	(2)	Auto 3MC	read/write	<input checked="" type="checkbox"/>	Enable automatic removal of low voltage ramp for high start pedestals
00000100	(4)	Auto Bypass	read/write	<input checked="" type="checkbox"/>	Enable automatic bypass contactor detection
00001000	(8)	Auto Jog	read/write	<input type="checkbox"/>	Enable automatic Jog detection. A stop request within about 0.5 seconds of a start request are forced to 0 stop time
00010000	(16)	Auto Endstop	read/write	<input type="checkbox"/>	Enable Detect stalled motor during softstop and turn off thyristors
00100000	(32)	Auto Stop	read/write	<input type="checkbox"/>	Detect variations in pf during stop smooth stall
01000000	(64)	Auto Endstart	read/write	<input type="checkbox"/>	Enable detection of full speed during start and complete start ramp
10000000	(128)	Auto Pedestal	read/write	<input type="checkbox"/>	Enable approximate detection of motor rotation at start and adjust pedestal to suit.

Parameter Bitmask	51	<i>USER FLAGS 1</i>	Name	Type	Default = ON	Description
00000001	(1)	Kickstart		read/write	<input type="checkbox"/>	Selects Kickstart (except in 3MC mode)
00000010	(2)	Current Limit Timeout selected		read/write	<input checked="" type="checkbox"/>	Selects Trip or continue on Current Limit timeout
00000100	(4)	Overload selected		read/write	<input checked="" type="checkbox"/>	Selects Overload operation
00001000	(8)	shearpin Selected		read/write	<input checked="" type="checkbox"/>	Selects Shearpin operation
00010000	(16)	Under Current Selected		read/write	<input type="checkbox"/>	Selects UnderCurrent operation
00100000	(32)	Thermistor Selected		read/write	<input type="checkbox"/>	Selects Thermistor operation
01000000	(64)	Unused		Status	<input type="checkbox"/>	
10000000	(128)	Remote Starting		Status	<input checked="" type="checkbox"/>	Start/stop through on board terminals

Parameter Bitmask	52	<i>USER FLAGS 2</i>	Name	Type	Default = ON	Description
00000001	(1)	Low Voltage SoftStop		read/write	<input type="checkbox"/>	Selects low voltage phase of stopping ramp
00000010	(2)	Not Global enable 1		read/write	<input type="checkbox"/>	Active low enable signal from Terminal
00000100	(4)	Not Global enable 2		read/write	<input type="checkbox"/>	Active low enable signal from bus
00001000	(8)	Pod Start/stop		read/write	<input type="checkbox"/>	Bus start/stop request
00010000	(16)	Board Start/stop		read/write	<input type="checkbox"/>	Terminal start/stop request
00100000	(32)	Main Contactor		Status	<input type="checkbox"/>	status of main incoming contactor signal
01000000	(64)	Second Parameter Set		read/write	<input type="checkbox"/>	Second parameter set will be loaded at start
10000000	(128)	Zero Start time		read/write	<input type="checkbox"/>	Starter goes directly to full conduction at start (for multiple motor soft stopping)

Parameter Bitmask	53	<i>USER FLAGS 3</i>		Type	Default = ON	Description
00000001	(1)	pf1	pol	read/write	<input checked="" type="checkbox"/>	Polarity of programmable flags (1)
00000010	(2)	pf2	pol	read/write	<input checked="" type="checkbox"/>	Polarity of programmable flags (2)
00000100	(4)	User Current limit		read/write	<input type="checkbox"/>	Bus requests a Start ramp hold
00001000	(8)	User trip		read/write	<input type="checkbox"/>	Bus requests a trip
00010000	(16)	Invert Controller input		read/write	<input checked="" type="checkbox"/>	Controller set point source is inverted before use in servo loop
00100000	(32)	Inhibit Restart		read/write	<input type="checkbox"/>	Inhibited restart control is enabled
01000000	(64)	Unused		Status	<input type="checkbox"/>	

Parameter Bitmask	54	<i>I/O POLARITY</i>		Type	Default = ON	Description
00000001	(1)	K1	Polarity	read/only	<input checked="" type="checkbox"/>	
00000010	(2)	K2	Polarity	read/only	<input checked="" type="checkbox"/>	
00000100	(4)	K3	Polarity	read/only	<input checked="" type="checkbox"/>	
00001000	(8)	K4	Polarity	read/only	<input checked="" type="checkbox"/>	
00010000	(16)	I/P 1	Polarity	read/only	<input checked="" type="checkbox"/>	
00100000	(32)	I/P 2	Polarity	read/only	<input checked="" type="checkbox"/>	
01000000	(64)	I/P 3	Polarity	read/only	<input checked="" type="checkbox"/>	
10000000	(128)	LED	Polarity (unused)	read/only	<input type="checkbox"/>	

FD8416 5MC Bit Parameters

03 September 2003

Software 55 .11

Parameter Bitmask	86	<i>Auto Config 2</i> Name	Type	Default = ON	Description
00000001	(1)	Auto Ramp	read/write	<input type="checkbox"/>	Gently ramps the voltage to the starter acting a bit like an automatic current limit.
00000010	(2)	Auto 3MC	read/write	<input checked="" type="checkbox"/>	Enable automatic removal of low voltage ramp for high start pedestals
00000100	(4)	Auto Bypass	read/write	<input checked="" type="checkbox"/>	Enable automatic bypass contactor detection
00001000	(8)	Auto Jog	read/write	<input type="checkbox"/>	Enable automatic Jog detection. A stop request within about 0.5 seconds of a start request are forced to 0 stop time
00010000	(16)	Auto Endstop	read/write	<input type="checkbox"/>	Enable Detect stalled motor during softstop and turn off thyristors
00100000	(32)	auto Stop	read/write	<input type="checkbox"/>	Detect variations in pf during stop smooth stall
01000000	(64)	Auto Endstart	read/write	<input type="checkbox"/>	Enable detection of full speed during start and complete start ramp
10000000	(128)	Auto Pedestal	read/write	<input type="checkbox"/>	Enable approximate detection of motor rotation at start and adjust pedestal to suit.

Parameter Bitmask	95	<i>USER FLAGS 1,2</i> Name	Type	Default = ON	Description
00000001	(1)	Kickstart (2)	read/write	<input type="checkbox"/>	
00000010	(2)	Current Limit Selected (2)	read/write	<input checked="" type="checkbox"/>	
00000100	(4)	Overload selected (2)	read/write	<input checked="" type="checkbox"/>	
00001000	(8)	shearpin Selected (2)	read/write	<input type="checkbox"/>	
00010000	(16)	Under Current Selected (2)	read/write	<input type="checkbox"/>	
00100000	(32)	Thermistor Selected (2)	read/write	<input type="checkbox"/>	
01000000	(64)	Unused	Status	<input type="checkbox"/>	
10000000	(128)	Remote Starting (2)	read/write	<input checked="" type="checkbox"/>	

FD8416 5MC Bit Parameters

03 September 2003

Software 55 .11

Parameter Bitmask	96	<i>USER FLAGS 2,2</i>	Name	Type	Default = ON	Description
00000001	(1)		Low Voltage SoftStop (2)	read/write	<input type="checkbox"/>	
00000010	(2)		Not Global enable 1 (2)	read/write	<input type="checkbox"/>	
00000100	(4)		Not Global enable 2 (2)	read/write	<input type="checkbox"/>	
00001000	(8)		Pod Start/stop (2)	read/write	<input type="checkbox"/>	
00010000	(16)		Board Start/stop (2)	read/write	<input type="checkbox"/>	
00100000	(32)		Main Contactor (2)	Status	<input type="checkbox"/>	
01000000	(64)		Second Parameter Set (2)	read/write	<input checked="" type="checkbox"/>	
10000000	(128)		Zero Start time (2)	read/write	<input type="checkbox"/>	

Parameter Bitmask	112	<i>STATUS 4</i>	Name	Type	Default = ON	Description
00000001	(1)		60 Hz	Status	<input type="checkbox"/>	The unit is using 60Hz parameters
00000010	(2)		RYB Sequence	Status	<input type="checkbox"/>	The phase rotation detected at start was ...
00000100	(4)		Shearpin	Status	<input type="checkbox"/>	Indicates current is above shearpin level
00001000	(8)		Under Current	Status	<input type="checkbox"/>	Indicates current is below under current level
00010000	(16)		Thermistor	Status	<input type="checkbox"/>	Thermistor is overtemperature or I/p's are open circuit
00100000	(32)		Timeout	Status	<input type="checkbox"/>	Current limit has timed out
01000000	(64)		Overload	Status	<input type="checkbox"/>	Overload has passed trip level
10000000	(128)		Thermal Switch	Status	<input type="checkbox"/>	Heatsink is above max allowed temperature

FD8416 5MC Bit Parameters

03 September 2003

Software 55 .11

Parameter Bitmask	120	<i>STATUS 5</i> Name	Type	Default = ON	Description
00000001	(1)	Over Temperature	Status	<input type="checkbox"/>	Inhibits re-start if set. Effectivley The heatsink is too hot to start but is ok to run.
00000010	(2)	Offline Command Fail	read/only	<input type="checkbox"/>	The last offline command failed , automatically reset when the next command is attempted.

Parameter Bitmask	121	<i>USER_FLAGS4</i> Name	Type	Default = ON	Description
00000010	(2)	Serial mode 2	Status	<input type="checkbox"/>	Allow for quicker comms response
00000100	(4)	Auto SoftsStop Smoothing	read/write	<input type="checkbox"/>	enable Soft stop smoothing for pumps
00001000	(8)	Breaker Present	read/write	<input type="checkbox"/>	Is the system to be used with a trippable breaker. Although selected by certain users this is not a prefered option, it is recommended that a line contactor is used as a switching off device.
00100000	(32)	Quick Ramp Times	read/write	<input type="checkbox"/>	This bit selects ramp times to be 10 times faster than the value entered although min = 0.3sec
01000000	(64)	Two Stop Bits	read/write	<input type="checkbox"/>	When set the comms will have two stop bits.

Parameter Bitmask	127	<i>Hidden Trip Flags</i> Name	Type	Default = ON	Description
00000001	(1)	Trip 1 Enabled	read/write	<input checked="" type="checkbox"/>	Enable or disable Trip 1 Phase Loss
00000010	(2)	Trip 8 Enabled	read/write	<input checked="" type="checkbox"/>	Enable or disable Trip 8 Motor side Thyristor Loss
00000100	(4)	Trip 9 Enabled	read/write	<input checked="" type="checkbox"/>	Enable or Disable Thyristor Sensing Trip Type A
00001000	(8)	Trip 10 Enabled	read/write	<input checked="" type="checkbox"/>	Enable or Disable Thyristor Sensing Trip Type B
00010000	(16)	Trip 4 Enabled	read/write	<input type="checkbox"/>	Enable or Disable Thyristor Sensing Trip Type C
00100000	(32)	Trip 5 Enabled	read/write	<input checked="" type="checkbox"/>	Enable or Disable Edge Sensing Trip
01000000	(64)	Trip 6 Enabled	read/write	<input checked="" type="checkbox"/>	Enable or Disable Sensing Trip Type A
10000000	(128)	Trip 7 Enabled	read/write	<input checked="" type="checkbox"/>	Enable or Disable Sensing Trip Type B

Tech Hints

Category General

No : 3 **Date :** 10/07/2002 **Subject :** Motor configuration

If the motor starts ok but stalls as soon as a load is applied then check the configuration of the motor, i.e it may be that the motor is meant to be connected in delta but is actually connected in star

No : 4 **Date :** 23/08/2002 **Subject :** Thermistor(1)

Thermistors are non linear devices, An analog input has been used to monitor the thermistor, with no thermistor connected the parameter will read 255, with a cold thermistor the value will be low or zero but with an over temperature thermistor the value will be high or 255.

No : 9 **Date :** 10/09/2002 **Subject :** Kick Start

Kick start is not always suitable for use with rolling starts or very light loads.

No : 12 **Date :** 05/11/2002 **Subject :** Fuse Bodies

Smaller Fuse bodies can age worse with repeated starts.

No : 15 **Date :** 02/09/2003 **Subject :** Modbus

From Software version 55.00 circuit board comms is by a subset of the modbus protocol.

No : 16 **Date :** 02/09/2003 **Subject :** Enable and Disable

From Software version 55.00 enable and disable modes are introduced, the unit must be disabled to save to permanent store etc.

No : 17 **Date :** 02/09/2003 **Subject :** Slip ring motors 1

When sizing a single stage of resistors for use with a soft starter, care must be taken to balance the standstill torque requirements against large slips at full volts.

No : 18 **Date :** 02/09/2003 **Subject :** Slip ring motors 2

Slip rings may be shorted at part voltage by forcing a user current limit at start, then using the current limit timeout flag to control K2 and hence the shorting contactor.

No : 20 **Date :** 02/09/2003 **Subject :** Commissioning 1

It is a good idea to start by using one of the standard applications.

No : 22 **Date :** 02/09/2003 **Subject :** Sizing Starters

Starters may need to be de-rated for high start frequency, current, ambient temperature, altitude or long starts.

No : 23 **Date :** 02/09/2003 **Subject :** Contactors

Contactors marked for example K1 on wiring diagrams are not included within the soft starters.

No : 25 **Date :** 02/09/2003 **Subject :** Soft Starts

Soft starters reduce motor starting current at the expense of reducing starting torque and increasing start time.

No : 26 **Date :** 02/09/2003 **Subject :** Start time with "Auto Ramp"

When "Auto Ramp" is selected the ramp time is an arbitrary number 1 being fastest upto 255 the slowest. The unit will be accelerated to full speed by the microprocessor with a varying ramp profile trying to keep the start current to a minimum.

Category Troubleshooting

No : 1 **Date :** 20/06/2002 **Subject :** Reset Trip

Trips can be reset by pressing the # key on the keypad or by changing the start/stop I/p to start if control is set to remote.

No : 5 **Date :** 09/09/2002 **Subject :** Load(1)

The softstarter will trip(8) if there is no motor connected on the output and a start is attempted.

No : 6 **Date :** 09/09/2002 **Subject :** Intermittant "7 Sensing signal" Trip

Normally caused by a noisy site. First try increasing the optimise rate , secondly increase trip sensitivity.

No : 7 **Date :** 09/09/2002 **Subject :** Stopped Cooling

This message is displayed during the cooling time (pnu116) and is the period allowed for the unit to cool before a restart.

No : 10 **Date :** 10/09/2002 **Subject :** Keypad Displays '2 Comms Failure'

Check that the unit has it's original front cover and keypad.

No : 13 **Date :** 31/03/2003 **Subject :** No Current Display

When running in "Phase Loss only" or "Start & Bypass" if the motor current drops below 12.5% IE then no value is displayed.

No : 19 **Date :** 02/09/2003 **Subject :** Cancelled 1

If trying to change from keypad to remote starting with a start signal present the display flashes "cancelled".

No : 21 **Date :** 02/09/2003 **Subject :** Commissioning 2

If the softstart trips on overload during the start, check starter is large enough for the load.

No : 24 **Date :** 02/09/2003 **Subject :** "Too Hot"

Check ventilation into the cabinet. If the unit has worked for a long time check fans and airflow through unit.

Category Wiring

No : 2 **Date :** 24/06/2002 **Subject :** When replacing star delta starters

If you are planning to re use the existing overload and contactor, ensure they are sized for the full motor line current and not just for delta phase current.

No : 8 **Date :** 09/09/2002 **Subject :** Running inside the DELTA 1

The unit must be set to firing mode 1. The current displayed is now the phase current (58% of the line current).

No : 11 **Date :** 11/09/2002 **Subject :** Running inside the DELTA 2

When running with firing mode 1 the maximum cable length between the starter and the motor is reduced to 50M.

No : 14 **Date :** 02/09/2003 **Subject :** Running inside the DELTA 3

When running in the delta an inline contactor must be used.

SFE3

Soft Start Motor Controller

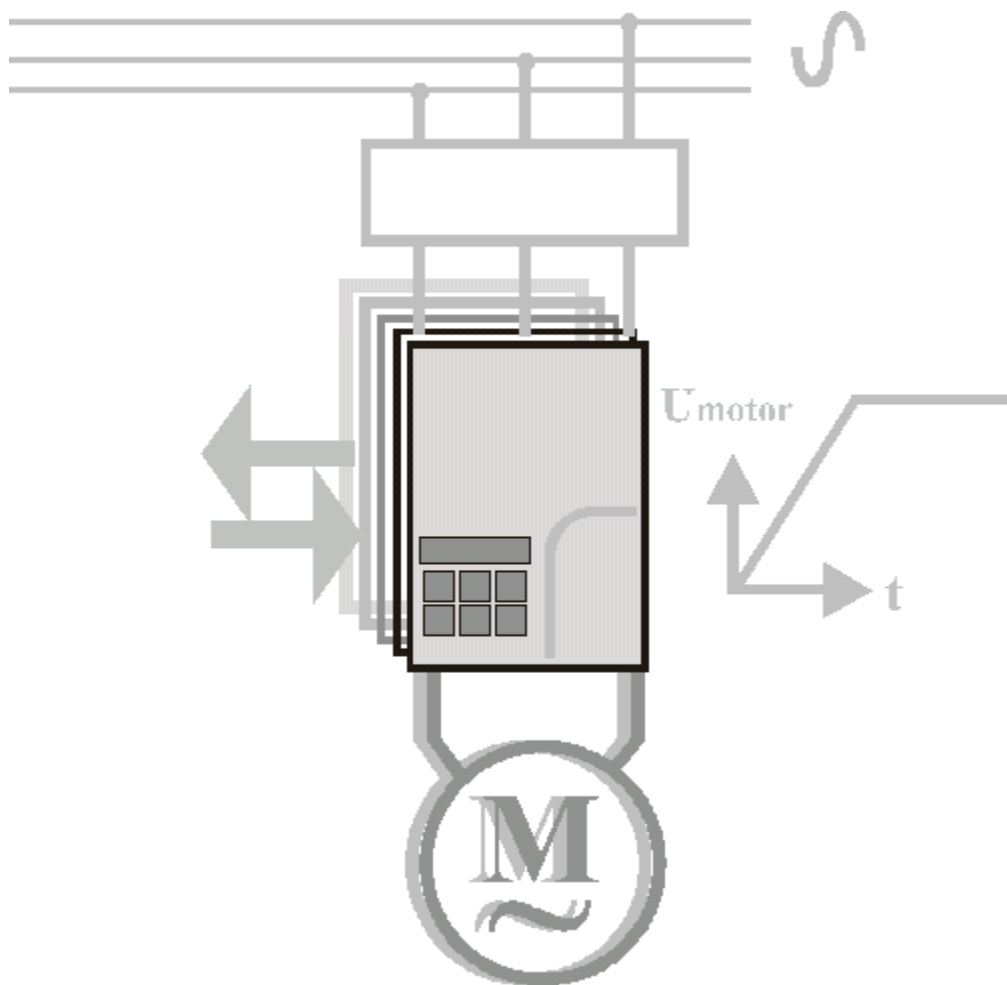

Technical Data for the SFE3 and SFE3-plus
Programming Guide

FD8420 issue02_C



WARNING

The owner, installer and user is responsible for the correct installation and use of the SFE3 and must ensure that only qualified personnel install the SFE3 and that the installation, operation and maintenance of the unit complies with the relevant Codes of Practice, Regulations and Statutory Requirements. The Manufacturer or his agent do not assume any liability, expressed or implied, for any consequence resulting from inappropriate, negligent or incorrect installation, application, use or adjustment of the product or circuit design, or from the mismatch of the unit to a motor. To prevent an electrical shock hazard the SFE3 must be connected to a safety earth. The unit is not designed for use in hazardous areas. Use in such an area may invalidate the hazardous area certification.

Copyright Information

All rights reserved. No part of this publication may be reproduced or transmitted in any form or by any means, electronic or mechanical including photocopying, recording, or by any information storage or retrieval system without written permission.

Copyright ©Fairford Electronics Ltd. 2003 Document Number FD8420 Issue 02. Published September 2003.

5	Programming	5-5
5.1	Versions	5-5
5.1.1	Useful Information	5-5
5.1.2	Conventions	5-5
5.1.3	Quick Start	5-5
5.2	User Interface	5-6
5.2.1	The Keypad and Keypod	5-6
5.2.2	Menu Structure	5-6
5.2.3	System Status Mode	5-8
5.2.4	Menu Navigation Mode	5-8
5.2.5	Data Entry Mode	5-8
5.2.6	Changing Parameter Values	5-9
5.2.7	Soft Starter Data Types	5-9
5.2.8	Bit Masks	5-9
5.2.9	Keypad/Keypod boot-up messages	5-10
5.3	Using the Menus	5-11
5.3.1	The Applications Menu	5-11
5.3.2	The Auto Menu	5-12
5.3.3	The Basic Menu	5-14
5.3.4	The Advanced Menu	5-15
5.3.5	The Current Menu	5-18
5.3.6	Permanent Store Menu	5-21
5.3.7	The Password Menu	5-21
5.3.8	The Inputs Menu	5-21
5.3.9	The Outputs Menu	5-22
5.3.10	The Parameters Menu	5-22
5.3.11	The Trips Menu	5-23
5.4	Setup Examples	5-25
5.4.1	Enabling and Disabling the QFE	5-25
5.4.2	How to read the Setup Examples	5-26
5.4.3	Loading the 'large pump' application into memory	5-28
5.4.4	Changing from 'Keypad Starting' to 'Remote Starting'	5-29
5.4.5	Permanently saving parameters set by the user	5-30
5.4.6	Loading the default parameter values with 'Keypad Starting' option	5-31
5.4.7	Loading the default parameter values with 'Remote Starting' option	5-32
5.4.8	Viewing basic operating parameter values via the Settings menu option	5-33
5.4.9	Changing a password	5-34
5.4.10	Unlocking and locking the keypad	5-35
5.4.11	Using the pre-programmed relay options	5-36
5.4.12	Setting the Low Amps Level, and using the K2 relay to display the status of Low Current bit	5-37
5.4.13	Using the K2 relay to mimic Programmable Input 1	5-40
5.5	Advanced Setup Examples	5-42
5.5.1	Using an Alternative Parameter Group	5-42
5.5.2	Changing the Parameter Group after the unit has passed Top of Ramp	5-44
5.5.3	Using the K3 relay to indicate a Stall (applies to plus units only)	5-48

- 5.5.4 Selecting Optimising with Programmable Input 1. 5-50
- 5.5.5 Selecting a 'Kick' Start with Programmable Input 3,
(applies to plus units only). 5-52
- 5.5.6 Selecting a Parameter Group with Programmable Input 2,
(applies to plus units only). 5-54
- 5.5.7 Using the K3 relay to indicate the Main Contactor status,
(applies to plus units only). 5-56
- 5.5.8 Using the 4-20mA input to monitor a level,
(applies to plus units only). 5-58
- 5.5.9 Using the DC input to set a parameter's value,
(applies to plus units only). 5-61
- 5.5.10 Mapping the Load Current to Analogue Output 2,
(applies to plus units only). 5-62
- 5.5.11 Mapping Programmable Input 2 to the User Trip,
(applies to plus units only). 5-63
- 5.6.1 Definitions 5-65

5 Programming

5.1 Versions

This manual applies to the following versions of software;

5MC software version: 5MC V 55.11

Keypad software version: V1.063

Menu software version: Menu V1.017

5.1.1 Useful Information

Further useful information can be found in the following documents which are available on the website, <http://www.fairford.co.uk>;

The Basic Guide to the Installation and Operation of the SFE3 Soft Starter

SFE3 Mechanical Installation Manual

SFE3 Electrical Installation Manual

SFE3 Applications Manual

SFE3 Electro-Magnetic Compatibility Manual

SFE3 Modbus Manual

5MC Parameter Listing

5MC Bit Parameters

Applications Data Listing

5.1.2 Conventions

The following typographical conventions are used in this manual;

1. Characters that are quoted directly from the SFE3's display are quoted in a fixed width font.

This includes menu names:

`Basic`

parameter names:

`Start Time`

parameter values:

`5 Seconds`

status information:

`Stopped and ready`

2. Buttons on the keypad/keypod to be pressed by the user will be indicated by their name, **Enter**, in **bold fixed width font**, or by the appropriate symbol; thus ▼ also in **bold**, for the decrement or move down button.

3. Where "SFE3+", or "applies to plus units only" is shown in the text it indicates that the functionality described by that section applies to SFE3+ units only, and **not** the standard SFE3 unit.

5.1.3 Quick Start

Once the unit is wired as per instructions in the Basic Guide or the Electrical Installation manual, then simply select a suitable application from the Applications menu (see section 5.4.3), and the unit can then be started with the keypad. This will give a good basic setup, but in some instances fine tuning will be required.

5.2 User Interface

5.2.1 The Keypad and Keypod

There are two types of user interface for use with the SFE3 - the **keypad** (refer to **Figure 5.2.1**) and the **keypod** (refer to **Figure 5.2.1a**). The **keypad** is the user interface which is internally mounted on the SFE3. The **keypod** is the user interface which is remotely mountable (up to 10 metres from the SFE3 soft starter). Only one interface may be used at any one time.

All parameters that control the operation of the SFE3 soft starter can be accessed via the interface. Parameters¹ and their values are shown on the interface display, and any changes to parameter values are effected by the using the buttons on the interface. The interface has three basic modes of operation;

- **System Status Mode**
- **Menu Navigation Mode**
- **Data Entry Mode**

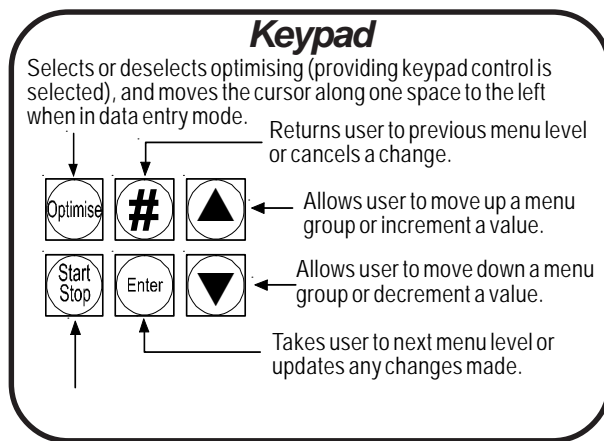

Figure 5.2.1 Keypad

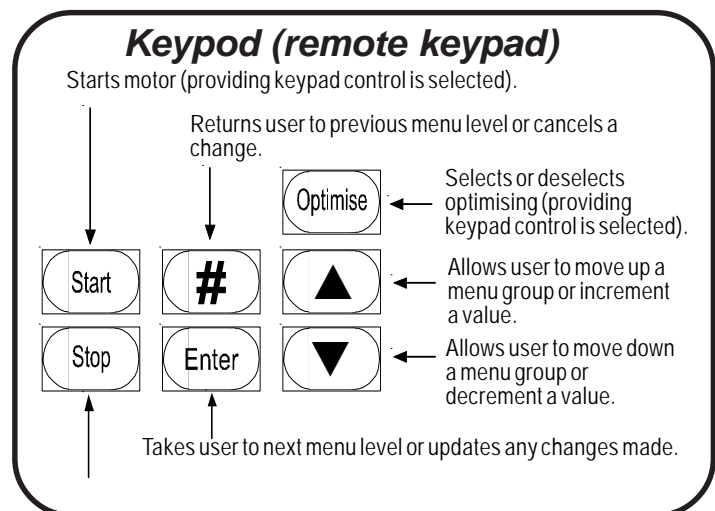

Figure 5.2.1a Keypod

Explanation of the modes mentioned above can be found in sections **5.2.3**, **5.2.4**, **5.2.5**.

5.2.2 Menu Structure

The menu structure of the user interface gives the operator two main routes via which they may change the operation of the SFE3; the text based menus or the number based parameter list. The menu items and parameters* which are most commonly used by the operator all reside in a text based menu structure which can be seen in **Figure 5.2.2**, on the page opposite. (**Note**; the values that appear in brackets after some entries are the default values of the menu items or parameters concerned). The number of menu items and parameters accessible from here is a little over half the total number of parameters available to the user in the SFE3. Access to all the parameters is available via the Parameters submenu, where each parameter has a name and a number assigned to it.

*Please refer to section **5.6.1** for the definition of a parameter used in this manual.

¹ A full list of parameters can be found in a printed extract of FD8416, available on the website as '5MC_Parameter_List.pdf' and '5MC_Bit_Parameter_List.pdf'.

SFE3 Menu Structure

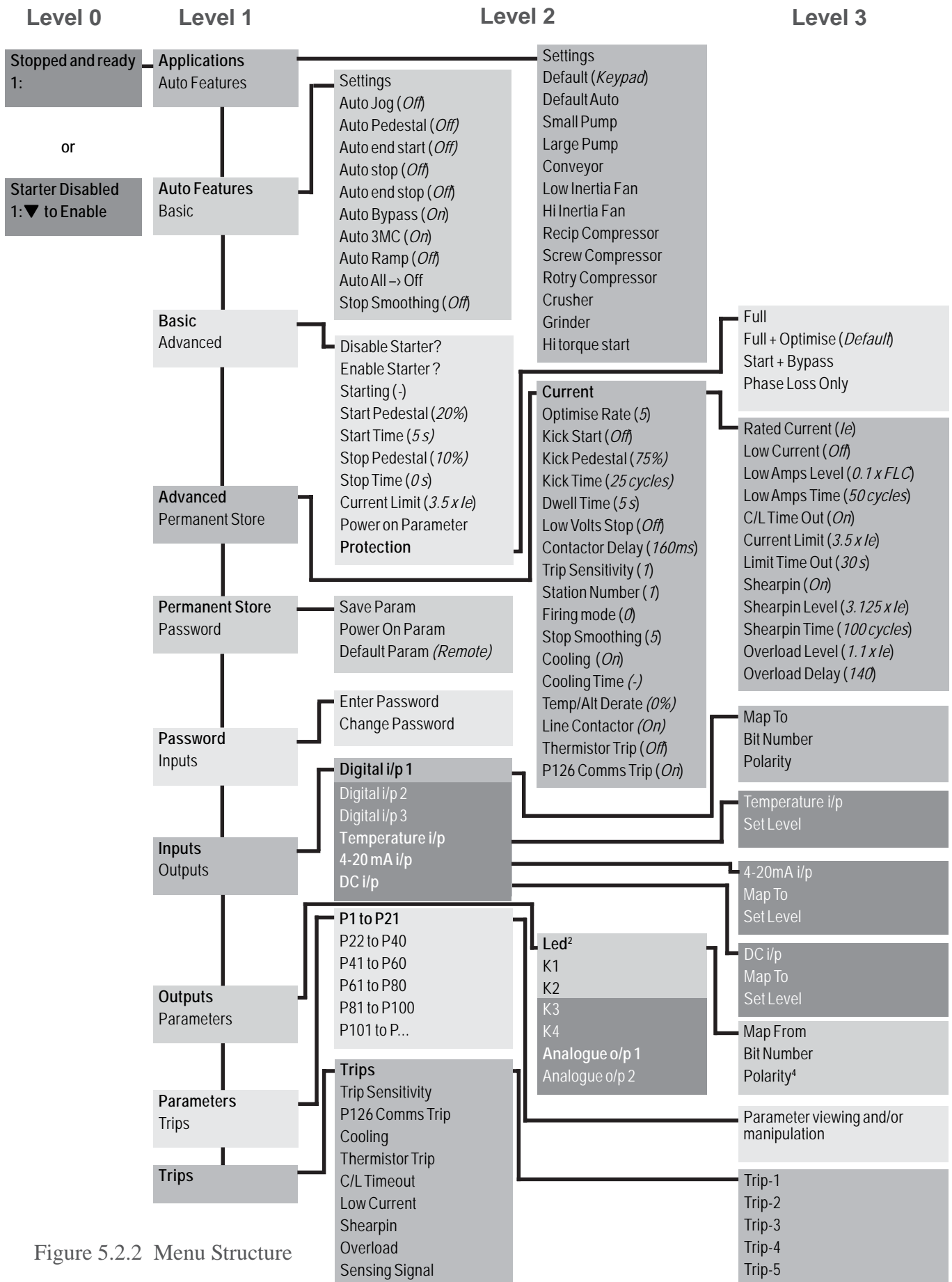

Figure 5.2.2 Menu Structure

Notes for Figure 5.2.2

1. Parameters that are listed in boxes with white writing on a dark background, thus;

White

will only be effective if the Auxiliary Function Card is fitted, as they are for use in conjunction with the extra hardware functionality that pcb provides.

2. The Led option in the Outputs menu will only be effective if 'Pots and Switches' software is used.
3. The menu structure may change in future versions and in software upgrades to the present version.
4. The Output relays can also be set to energise on the following pre-programmed events (Led cannot be energised on these events, see note 2).

K=Run Relay
K=Bypass Relay
K=Alarm
K=CurrentLimitng
K=OvldIntgrating
K=Stall
K=Cooling
K=EnableStatus

(Messages are shown as they are seen on the display).

These choices are available in the menu structure but are shown here for clarity. See also section 5.3.9

5.2.3 System Status Mode

Following the initial boot-up report (see section 5.2.9) the unit enters the status mode. In this mode the operating status of the unit is constantly displayed, resulting in a number of status messages;

Non-Running Status - both of two messages indicate that the unit is not running the load at present, but Stopped and Ready indicates the unit is enabled, and Starter Disabled indicates that the unit is disabled, (see section 5.4.1).

Fault number Fault description - this message indicates that a fault has occurred, giving the fault number and a short fault description such as "#1 Phase Loss". The second line of the message tells the user to reset the unit with the # key.

Temporary Comms Status Errors - these messages, CRC Error, Slave Busy, Illegal Address, Illegal Function tell the user when there has been a Modbus Comms Error. Please refer to the Modbus Manual for more details.

Running Status - this message indicates which running modethe unit is in either, "Starting", "Full Volts", or "Optimising". The second line of the message gives a current indication in Amps. If an overload condition exists then a bar graph indicating the state of overload integration will be shown across both lines on the right hand side of the display.

5.2.4 Menu Navigation Mode

The Menu Navigation Mode is entered as soon as the Enter button is pressed in System Status Mode. In this mode the user can navigate through all levels of the menu structure using the relevant buttons on the keypad, see Figure 5.2.1/5.2.1a .

5.2.5 Data Entry Mode

The Data Entry Mode is entered as soon as the bottom level of the menu structure for that particular menu branch is reached, i.e. a menu item or parameter name is displayed in the top line of the keypad display, and the associated value is displayed in the bottom line of the display. Not all parameter values can be changed by the user, as some are read-only.

A user can tell whether the menu item or parameter is writeable as there will be a flashing cursor present on the bottom line of the display if writing is permitted. Writeable values may be changed by using the up and down keys (for a numerical value) or by pressing **Enter** (for a change in a logic value). In the first case (a numerical value) the **Enter** key must be pressed to confirm the changed value. The user interface display will flash once to confirm the change.

5.2.6 Changing Parameter Values.

All parameters can be read by the user, and some parameters can also be written to by the user. The full list of parameters and their values can be found in the `Parameter` menu and subsequent sub-menus. The most commonly read and written to parameters can also be found under the other Level 1 (see Figure 5.2.2) menus such as `Basic` and `Applications`. A simple example of how to view and change a parameter value is given in section 5.4.3 .

5.2.7 Soft Starter Data Types

There are basically four types of data held in parameters, Analogue, Multiple, Percentile and Bit data. Their definitions are given below.

Analogue data - one of a range of values between two extremes, usually 0-255, 0-50 or 0-10, that represent units such as volts, amps, seconds etc...; for example `Start Time (Stopped & ready -> Basic -> Start Time)` would be set at 5 seconds on default, but can be set to a maximum of 255 seconds.

Multiple data - a multiple of an absolute quantity; for example, the running current displayed by the unit is a multiple of the value of the unit's `Rated Current` (e.g. `1.0 x Rated Current` to `8.0 x Rated Current`). Note, normally the unit's `Rated Current` approximates to motor or load `Full Load Current`.

Percentile data - percentage value of an absolute quantity, ranging from 0 - 100%; for example, the `Kick Pedestal (Stopped & ready -> Advanced -> Kick Pedestal)` is the percentage of supply voltage applied to the unit during an optional start-up 'kick'.

Bit data - this represents the selection or non-selection, turning 'On' or turning 'Off' of whichever bit parameter is in question.

5.2.8 Bit Masks

Some parameters can also be addressed via the appropriate Bit Parameter, instead of or as well as being accessed via the more commonly used menus. These Bit Parameters can only be accessed by the `Parameters` menu, i.e. for the `Auto Config Bit Parameter` the menu path would be; `Stopped & ready -> Parameters -> P1 to P20 -> P18 Auto Config`. The user would then see a display similar to the one below;

Parameter Name; `P18 Auto Config`
 Bit data; `00000110 Flags`

Bit number; `7.....0`

Note; only the text in the shaded box would actually be displayed by the user interface.

5.2.8 continued

A cursor would be flashing at the character on the display which represents the Least Significant Bit (LSB, also known as bit 0; i.e. the 0 or 1 on the right hand side of the eight 0's and/or 1's). This character is actually underlined for clarity in the example above.

The cursor represents the user's current input point, the value of the bit highlighted by the cursor can now be changed. To move the cursor one place to the left the user needs to press the **Optimize** key, and the user will then be able to edit bit 1. Pressing the **Optimize** key repeatedly will continue to move the cursor one place to the left until bit 7, or the Most Significant Bit (MSB; the 0 or 1 on the left of the eight 0's and/or 1's) is reached, after which pressing the **Optimize** button again will wrap the cursor around to bit 0.

To continue with the example let us suppose that the user wishes to enable the `Auto Pedestal` (bit 7) and disable the `Auto Bypass` (bit 2). First, the user should press the **Optimize** button twice to move the cursor two places to the left, to bit 2. Then to change the value of bit 2 from '1' to '0', the user would simply press the **▼** key once. To move the cursor to the `Auto Pedestal` bit (bit 7), the user would now need to press the **Optimize** button five times. Then to turn on the `Auto Pedestal` bit, just pressing the **▲** key once will change the bit to the required value. To confirm the changes made the user would then press the **Enter** button. Not pressing the **Enter** would effectively cancel the changes made by the user.

5.2.9 Keypad/Keypod boot-up messages

When the control supply to the SFE3 is switched on, the user interface will go through a boot-up procedure during which it will display some information relevant to the SFE3's current state. The messages are displayed during the boot-up procedure in the order that they are listed below. A brief explanation of each message is included.

Fairford System

V1.063 03/09/01

This message shows the keypad software version number and it's release date.

1 Find Starter

This message indicates that the keypad is looking for a starter (soft start unit), starting with a station number of 1. If it is unable to find a starter with that station number, it will move onto station number 2 etc.. until 32, the highest valid station number, is reached. See section **5.3.4** for further details.

Password is Set

This message appears if the password has been set.

Stopped & ready
1:

Stopped and ready is displayed after the end of a successful boot-up procedure. The number on the second line is the station number of the unit that the keypad/keypod is currently talking to.

5.3 Using the Menus

This section gives a brief description of the individual menus and the functions that their parameters perform.

5.3.1 The Applications Menu

This menu contains a list of typical applications for which a set of parameters have been predefined by the manufacturer. This feature provides a quick and easy way of setting up the unit. There are three exceptions to this list: the first menu item, *Settings*, provides a brief report on the basic settings of the unit (see below and section 5.4.6); the second menu item, *Default (keypad)*, provides a way of loading the default parameter values with *Keypad Starting* as the choice for the starting option (see section 5.4.4); the third menu item, *Default Auto*, loads default parameter values and additionally turns on a number of features from the Auto Features menu. Further details can be found in the following documents, SFE3 Applications Data and the 5MC Bit Parameters.

Apart from these exceptions, the parameters that will be altered when one of the typical applications (small pump etc..) is selected are again listed in the documents SFE3 Applications Data and the 5MC Bit Parameters which can be found on the website.

Settings report; below is a list detailing the report given by the *Settings* menu item. When accessed it will display some information relevant to the SFE3's current state. The messages are displayed in the order that they are listed below. A brief explanation of each message is included (see section 5.4.6 on how to access this report).

V1.063 03/09/01	This message shows the keypad software version number and it's release date .
5MC V 55.11	This message gives the version number of the software in the 5MC control board.
Menu V1.017	This message gives the version number of the navigating menu.
Remote/ Keypad Starting	This message indicates whether the Starting Parameter has been set to keypad, or remote starting.
Full/ Full&Opt/ Start&Bypass/ Phase Loss Only	This message shows what protection mode has been set in the Protection Parameter.
Small Pump	This next message will show what (if any) application has been set from the Application menu (Small Pump is shown as an example). If no application has been set then the display will appear blank for a couple of seconds.
Temp/Alt Derated	This message will be displayed if the unit has been derated for temperature or altitude. If no derating has been set then the display will appear blank for a couple of seconds.

5.3.2 The Auto Menu

The Auto Menu contains commonly used parameters that may be automatically adjusted by the unit. A brief description of each entry is given below.

Settings - When active this menu item will provide a brief report on which, if any, Auto options have been switched On. A downwards facing arrow will appear on the right hand side of the top line of the user interface display. Whilst this icon is present all of the Auto options that appear on the bottom line of the display have been switched On.

Auto Jog - This menu item turns On and Off automatic Jog detection. When a soft stop time of greater value than zero (0) is set and Auto Jog is turned On, a stop request received by the unit within 0.5 seconds of a start request, forces the unit to execute a zero (0) second stop. This menu item is intended to be used for short term jogging of light loads. The default value for this menu item is Off.

Auto Pedestal - This menu item turns On and Off the automatic overriding of the start pedestal. When On the unit approximately detects the start of motor rotation and tries to adjust the pedestal to suit. The default value for this menu item is Off.

Auto End Start - This menu item turns On and Off the automatic detection of motor full speed during the start-up. Having detected motor full speed achieved before the end of the programmed ramp, this menu item brings forward the end of the ramp cutting short an overlong programmed start. The default value for this menu item is Off.

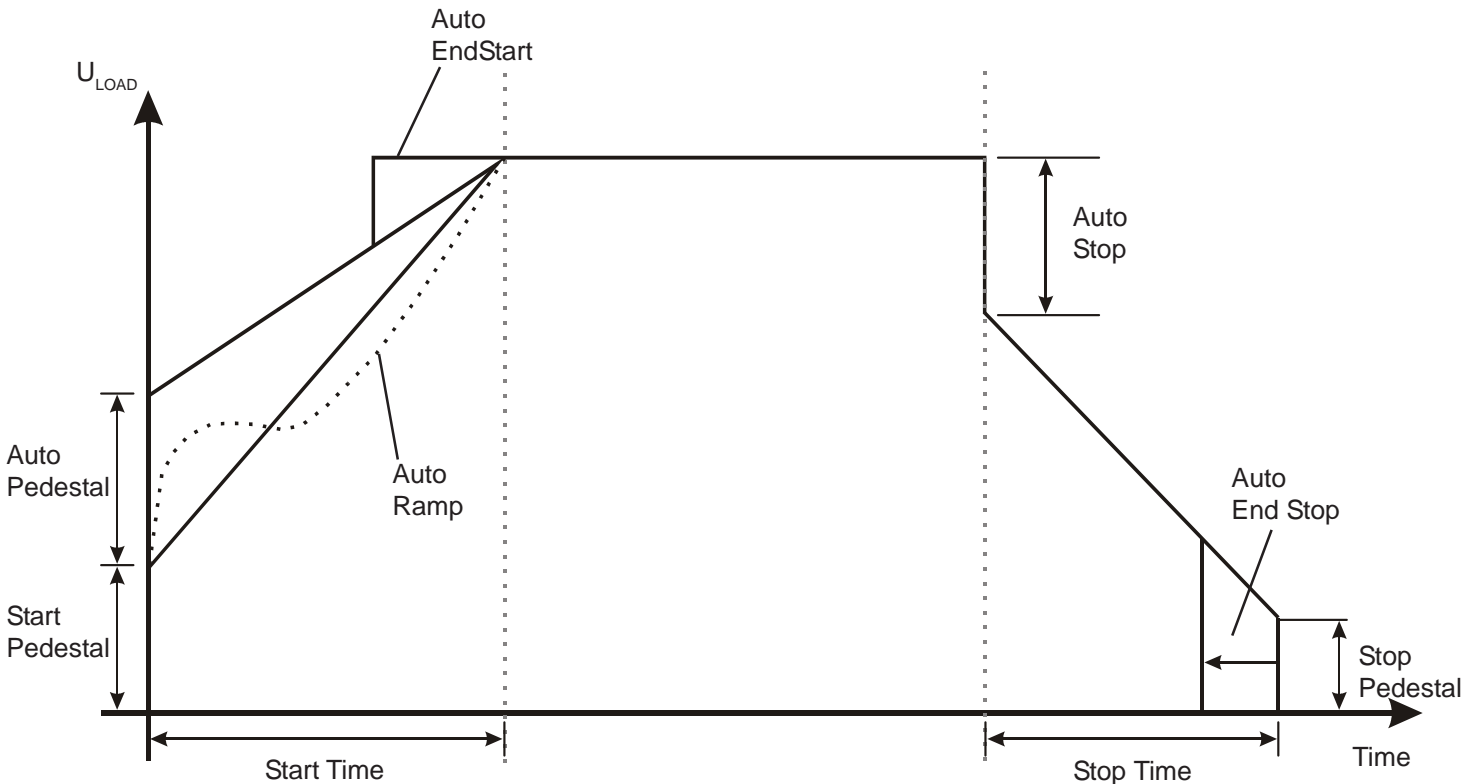

Figure 5.3.2 'Autos' Menu Explained

- Auto Stop - This menu item turns On and Off the automatic adjustment of the soft stop. When On the unit attempts to automatically adjust the soft stop profile to suit the load. The default value is Off.
- Auto End Stop - This menu item turns On and Off the automatic detection of a stalled motor during soft stop. When On and the motor has stopped before the end of the unit's programmed soft stop the unit will attempt to detect the stall and turn off the thyristors thus truncating the soft stop time. The default value for this menu item is Off.
- Auto Bypass - This menu item turns On and Off the automatic detection of a bypass contactor. When On a bypass contactor will be detected. The default value for this menu item is On.
- Auto 3MC - This menu item turns On and Off the automatic removal of the low voltage ramp for high pedestal starts. When this menu item is turned On and the Start Pedestal is set to 50% or more then a greater starting torque is applied to the load. The default value for this menu item is On.
- Auto Ramp - This menu item automatically detects motor acceleration and dynamically adjusts the ramp to give smoother acceleration. This menu item works in conjunction with the Start Time parameter (P12) which should be set to the estimated start time of the load. This would be suitable for starts with varying loads. The default value for this menu item is Off.
- Auto All - Off - This menu item turns Off all the Auto options (all options contained in this submenu except Stop Smoothing). The only action of this menu item is to turn Off all the Auto options when the menu item is activated.
- Stop Smoothing - This menu item turns On and Off the soft Stop Smoothing function. When turned On this menu item attempts to eliminate any oscillations that may occur when the unit soft stops with an unstable load. The default value for this menu item is Off.

5.3.3 The Basic Menu

The Basic menu holds the parameters which control the primary functions of the unit (see Figure 5.3.3). Changing the values of these parameters will vary the starting and stopping duties, the trip protection set for the unit and the source of the start signal (Keypad or Remote). The following section briefly details what each menu item in the menu will do.

Disable Starter? - This parameter disables the starter. Whilst the unit is disabled it will not comply with a start signal. Disabling the starter also allows the user to change certain parameters which cannot be changed whilst the unit is enabled (such as Password, and Station Number).

Enable Starter ? - This parameter enables the starter. Whilst the unit is enabled it will comply with a start signal. Some parameters cannot have their values changed whilst the unit is enabled.

Starting - This sets the source for the start signal. If set to Keypad the unit will start/stop when the **Start/Stop** button on the user interface is pressed. If set to Remote the unit will start when signalled to do so by an external circuit.

Start Pedestal - This is the percentage of the unit's rated supply voltage, that is applied to the load before the ramp starts.

Start Time - This is the time the unit takes to ramp up from the Start Pedestal (U_{START}) to the maximum applied voltage (U_{MAX}).

Stop Pedestal - This is the percentage of the unit's rated supply voltage that the applied voltage falls to, at the end of the stop ramp (U_{STOP}).

Stop Time - This is the time the unit takes to ramp down from the maximum applied voltage (U_{MAX}) to the Stop Pedestal (U_{STOP}).

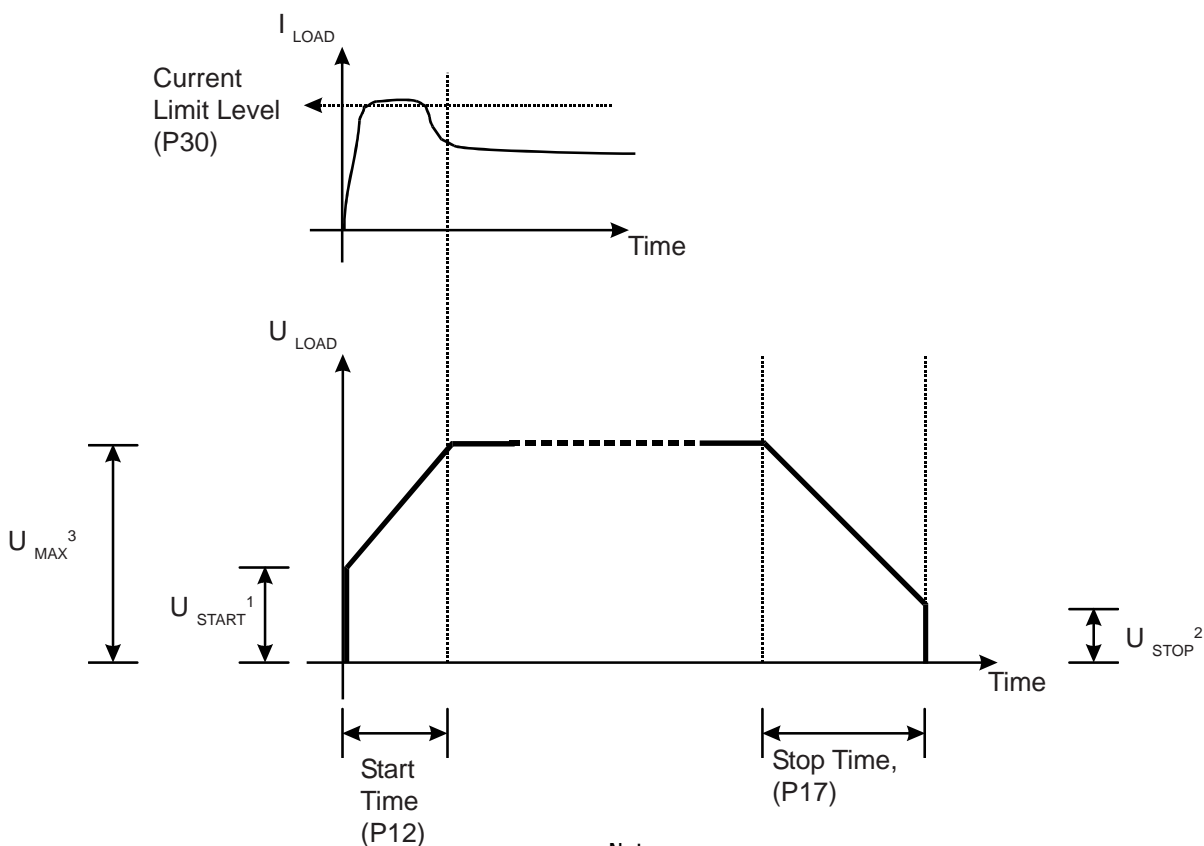

Notes;

1. This is the Start Pedestal voltage (P 11).
2. This is the Stop Pedestal voltage (P 16).
3. This is the supply voltage minus the voltage that is dropped across the SFE3.

Figure 5.3.3 'Basic' Menu Explained

Current Limit - This is the level of load current at which the unit stops ramping up the voltage applied to the load, and prevents the ramp from continuing within a time limit. At the end of the time limit (**Limit Time Out**, P31, see section 5.3.5) the unit will either stop or continue depending on the value of **C/L Time Out** in the **Current** menu (section 5.3.5). The default for this parameter is $3.5 \times \text{Full Load Current}$.

Notes: 1. The actual current drawn by the load may exceed the Current Limit Level slightly as the unit manages the current limit through control of the delay angle. 2. Current Limit is only active during starting.

Power On Parameters - This recalls the values from the last permanently saved parameter set and loads them into the current configuration.

Protection - This sets the trip modes which are available to the user and also enables the user to turn on and off the Optimising Function. The available protection modes are;

FULL: all trips enabled, optimising function turned off;

FULL + OPTIMISE: all trips enabled with optimising function turned on;

START + BYPASS: all trips enabled during start and trips 4 -10 (see section 5.3.11) turned off during bypass;

PHASE LOSS ONLY: trips 4 -10 are turned off, all others enabled.

5.3.4 The Advanced Menu.

The Advanced Menu holds parameters that only need to be changed to solve specific sets of circumstances. The list that follows briefly explains what each menu item does.

Current - Provides access to the **Current** (as in Amps) submenu.

Optimising Rate - This parameter is an arbitrary number which dictates the speed at which the unit will phase back the firing angle during optimising. The smaller the number the faster the unit will reach it's final optimising voltage. Some unstable loads benefit from a slower optimising rate (which equates to a larger **Optimising Rate** (number)), for example reciprocating compressors and piston pumps which can experience very quick changes in load. The default for this parameter is set to five (5).

Kick Start - This menu item turns the Kick Start function **On** or **Off**. The Kick Start applies a short-lived voltage kick at the beginning of the start ramp to dislodge 'sticky' loads. This is turned **Off** by default.

Kick Pedestal - This parameter sets the voltage level for the Kick, as a percentage of U_{MAX} . The default value is 75%.

Kick Time - This parameter sets the duration of the Kick in supply frequency cycles. I.e., UK supply frequency is 50Hz, so one cycle takes 20ms to pass, so the default Kick Time of 25 cycles equates to 500ms.

Dwell Time - This parameter sets the time given for a load to settle down after the unit has reached Top of Ramp and before the unit enters Optimising mode (if set).

Low Volts Stop - This menu item turns **On** or **Off** the **Low Voltage Stop** function. When **On** this allows soft stop pedestals of less than 40% to be set. Soft stop pedestals of 40% and less can be set with the **Low Volts Stop** set to **Off**, but they will be treated by the unit as a 40% soft stop pedestal. By default this menu item is turned **Off**.

Contactor Delay - This parameter sets the length of the delay between the Relay K1 closing (which brings in the main contactor in the standard wiring configuration, see Electrical Installation), and the moment the unit starts conduction (see Figure 5.3.4). This is to allow any bounce in the main contactor to settle down before the unit starts firing, thus preventing nuisance tripping. By default this parameter is set to 160mS.

Trip Sensitivity - This parameter sets a tolerance level for the unit's sensitivity towards trips. The higher the value this parameter is set to, the less sensitive the unit is to trip conditions. This is set to one (1) by default.

Station Number - This parameter holds the local network ID for this unit. This is set to one (1) by default.

Firing Mode - This parameter holds a value which corresponds to one of six different firing modes which are intended for use with the following load types;

Firing Mode 0, for normal squirrel cage motors connected in *star* or *delta* (with the soft start unit outside the *star* or *delta* configuration);

Firing Mode 1, for applications where the soft start unit is connected inside the *delta* configuration of a squirrel cage motor;

Firing Mode 2, for static loads with the soft start unit using a closed loop control method (SFE3+ only);

Firing Mode 3, for static loads with the soft start unit using an open loop control method;

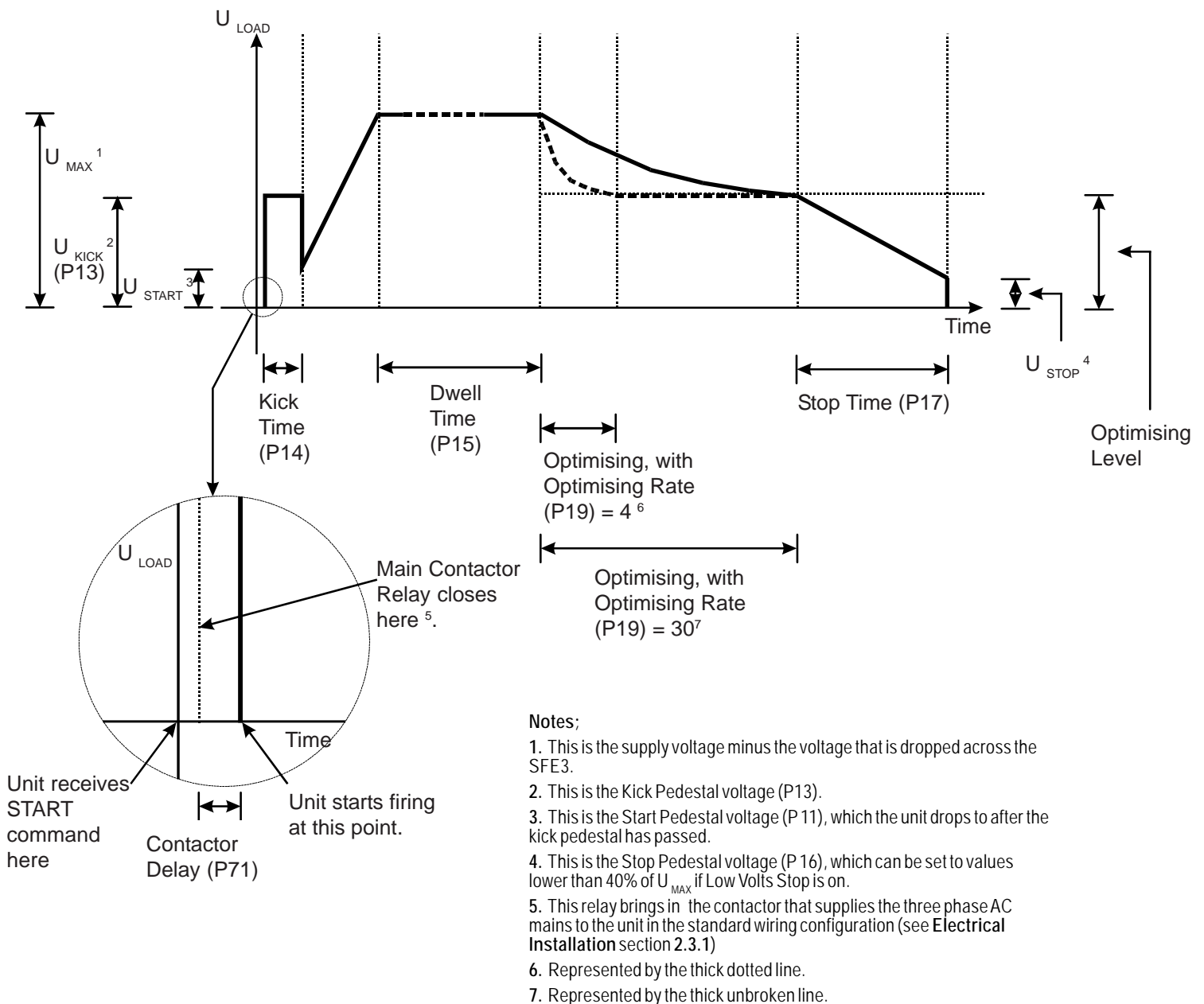

Figure 5.3.4 The Advanced Menu

Firing Mode 4, for static loads with the *star* point connected to the neutral, and the soft start unit using a closed loop control method (SFE3+ only);

Firing Mode 5, for static loads with the *star* point connected to the neutral, and the soft start unit using an open loop control method.

This parameter is set to mode zero (0) by default.

Stop Smoothing - This parameter stores a value which is used by a software filter to smooth any irregularities during a soft stop, caused by an unstable load. This parameter is used in conjunction with **Low Volts Stop** (see above) and also **Stop Pedestal** (see section 5.3.3). **Low Volts Stop** must be turned On and **Stop Pedestal** set to 40% or less, for **Stop Smoothing** to have any effect. The maximum numerical value that **Stop Smoothing** can be set to is fifteen (15), which gives the minimum amount of soft stop smoothing. This parameter is set to five (5) by default.

Cooling - This menu item turns On and Off the **Cooling** function. Once this menu item has been turned On and the unit has been started and subsequently stopped, the **Cooling** function inhibits the start command (not allowing the unit to start), until the time held in **Cooling Time** has elapsed (measured from the last stop signal). During this period the unit displays **Stopped. Cooling**. This menu item is mainly for use in commissioning soft start units that have large thyristor stacks, it's purpose being to avoid damage to the thyristors during the commissioning process. For all units this menu item is turned On by default.

Cooling Time - This parameter holds the time in seconds that the soft start unit will ignore a start signal, if **Cooling** is turned on (see above). By default, this is set to zero (0) for units of less than 242A. For units of 242A and above the default value is 420 seconds (7 mins). This default value can be extended but should **NOT** be reduced as it will invalidate the manufacturer's warranty.

Temp/Alt Derate - This parameter enables the user to derate by percentage of Unit Full Load current, where local temperature or altitude is outside of the normal operating range (see sections 1.4/1.5 of Mechanical Installation). This is set to zero (0) by default.

Line Contactor - This menu item turns On and Off the **Line Contactor** function, which selects the use by the customer of an in-line contactor in his wiring configuration. This menu item is On by default. **Note:** the Electricity At Work regulations of 1989 infer that any solid state starter cannot be considered as being a switching off device, and therefore an in line contactor should be used (regulation 12). However, if the decision is made to use a breaker instead, a new mode has been introduced so that the softstart can trip the breaker via the alarm relay when it is in the **Stopped and ready** state (see section 5.2.3). This helps to eliminate the problems that arise when the breaker is closed and a faulty softstart has short circuit devices. The breaker option is selected by turning this menu item, **Line Contactor, Off**, or by enabling **bit 3 of User Flags 4 (P121)**. **Please note** that an in-line contactor **MUST** be used with 'In Delta' mode, and that the use of an in-line contactor is **always** recommended.

Thermistor Trip (SFE3+) - This menu item turns On and Off the **Thermistor Trip** function. When the customer plugs the output of his motor thermistor into the relevant contacts on the add-on card (see the Electrical Installation Manual, sections 2.5.4 and 2.7.2), and this trip is activated, then the starter will trip whenever the thermistor goes 'over-temperature'. This set to **Off** by default.

P126 Comms Trip - This menu item turns On and Off the Modbus protocol **Comms Trip**. When activated the soft start unit must have serial communication every five seconds or the unit will trip. For further details see section 5.2.3 and the Modbus Manual. This menu item is On by default.

5.3.5 The Current Menu

The Current submenu contains all the parameters associated with the Unit Full Load Current, and it's associated trip levels. A short explanation of each item in the menu is given below.

Rated Current - This parameter holds the value of the soft starter's rated current. It cannot be altered by the customer.

Low Current - This menu item turns On and Off the Low Current trip. A Low Current trip occurs when the current output measured by the unit falls below the level specified by the Low Amps Level parameter for a length of time specified by the Low Amps Time parameter. The default value is Off.

Low Amps Level - This parameter specifies the current level below which a Low Current trip can occur. The default value is $0.1 \times$ Unit Full Load Current.

Low Amps Time - This parameter specifies the time that the current must remain below the level specified by the Low Amps Level before a Low Current trip occurs. The time is specified in supply frequency cycles. The default value is 50 cycles.

C/L Time Out - This menu item turns On and Off the Current Limit Time Out trip. A Current Limit Time Out trip will occur if this menu item is set to On, and the load is demanding more current than the level specified in the Current Limit parameter, for longer than the time specified in the Limit Time Out parameter. If the C/L Time Out menu item is set to Off then no trip would occur in a similar situation. The default value for this menu item is On. (See Figure 5.3.5b below).

Current Limit - This parameter sets the level in Amps at which the unit will begin current limiting. The default is equivalent to $3.5 \times$ Unit Full Load Current, but is expressed in Amps.

Limit Time Out - This parameter sets the time in seconds that the unit must be in a current limit situation for a current limit trip to occur. The default value for this parameter is thirty seconds.

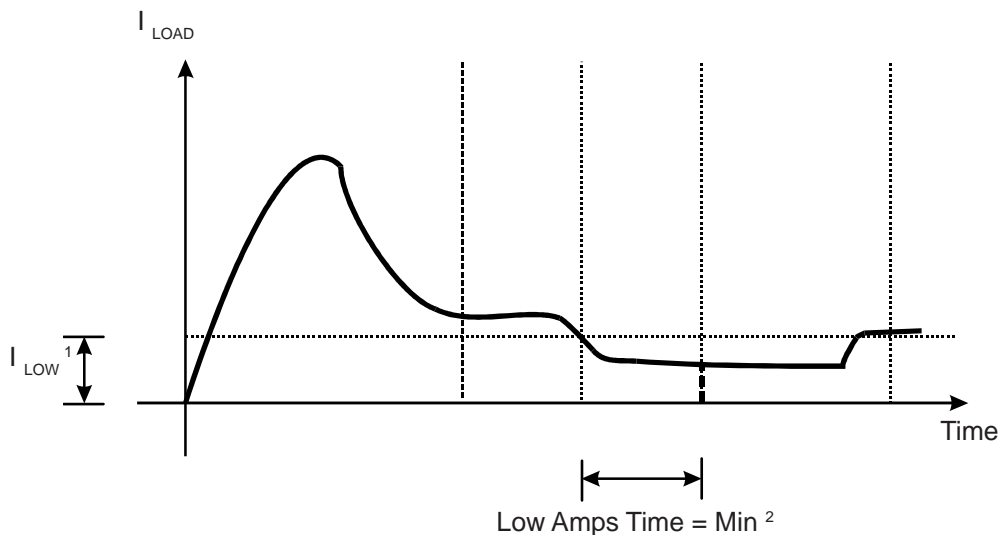

Notes

1. I_{LOW} = Low Amps Level.
2. If I_{LOAD} drops below 'Low Amps Level' and 'Low Current' is set to 'on', and 'Low Amps Time' is set to minimum then the unit will trip as indicated by the short thick dotted line.
3. If 'Low Amps Time' is set to maximum and I_{LOAD} rises above 'Low Amps Level' before 'Low Amps Time' has elapsed then the unit will not trip.

Figure 5.3.5a Low Current Protection

Shearpin - This menu item turns On and Off the Shearpin trip. The Shearpin trip is intended to catch transient current peaks which exceed the value specified in the Shearpin Level parameter for a time that is specified in the Shearpin Time parameter. The default value is On. **Note** - the Shearpin trip is automatically turned off during starting and stopping. See also the **Special Case** in the Overload Level entry on the next page.

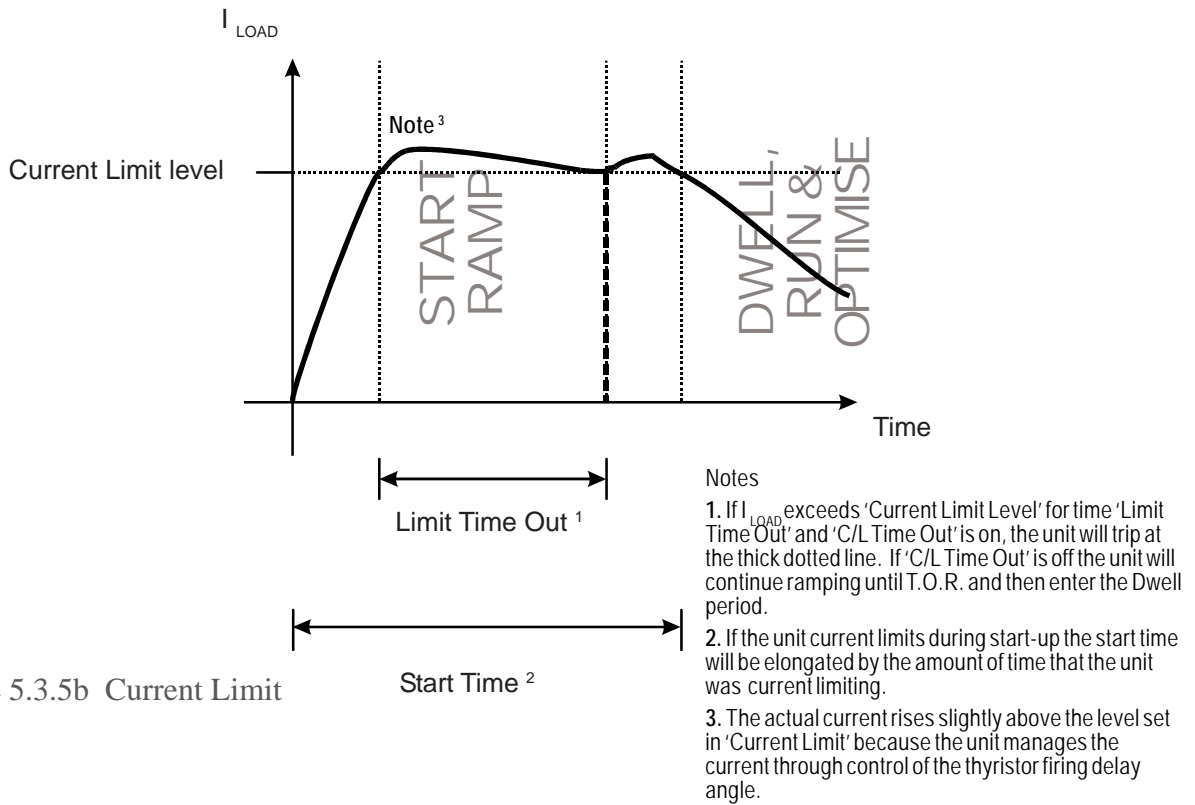

Figure 5.3.5b Current Limit

Shearpin Level - This parameter holds the level in Amps at and above which a Shearpin trip condition will exist. The default is equivalent to $3.125 \times$ Unit Full Load Current, but is expressed in Amps.

Shearpin Time - This parameter holds the time in supply frequency cycles that a Shearpin trip condition must exist for before a trip occurs. The default value is one hundred cycles (at the supply frequency).

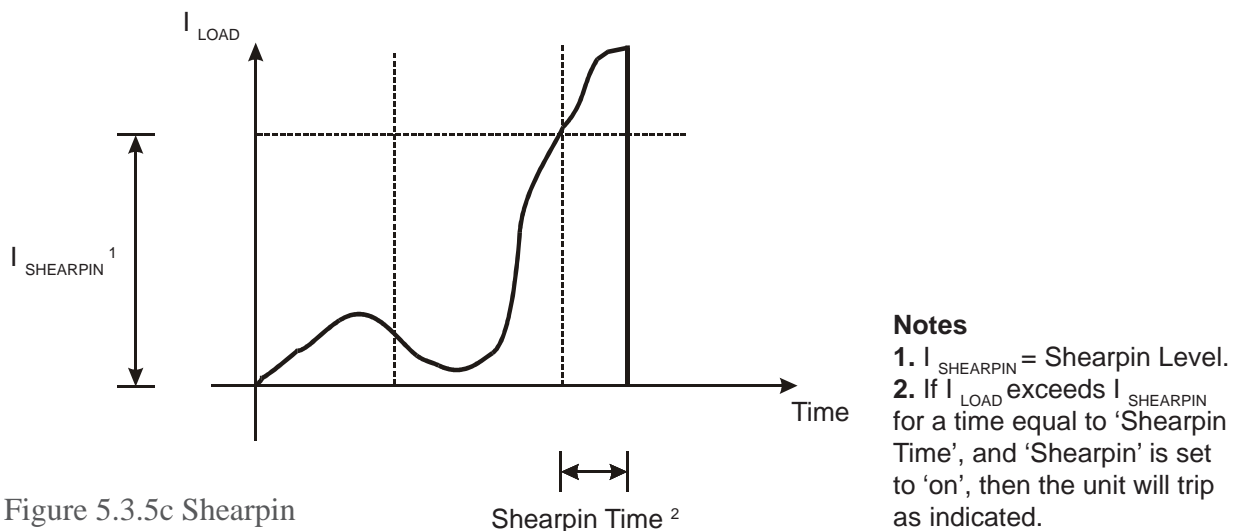
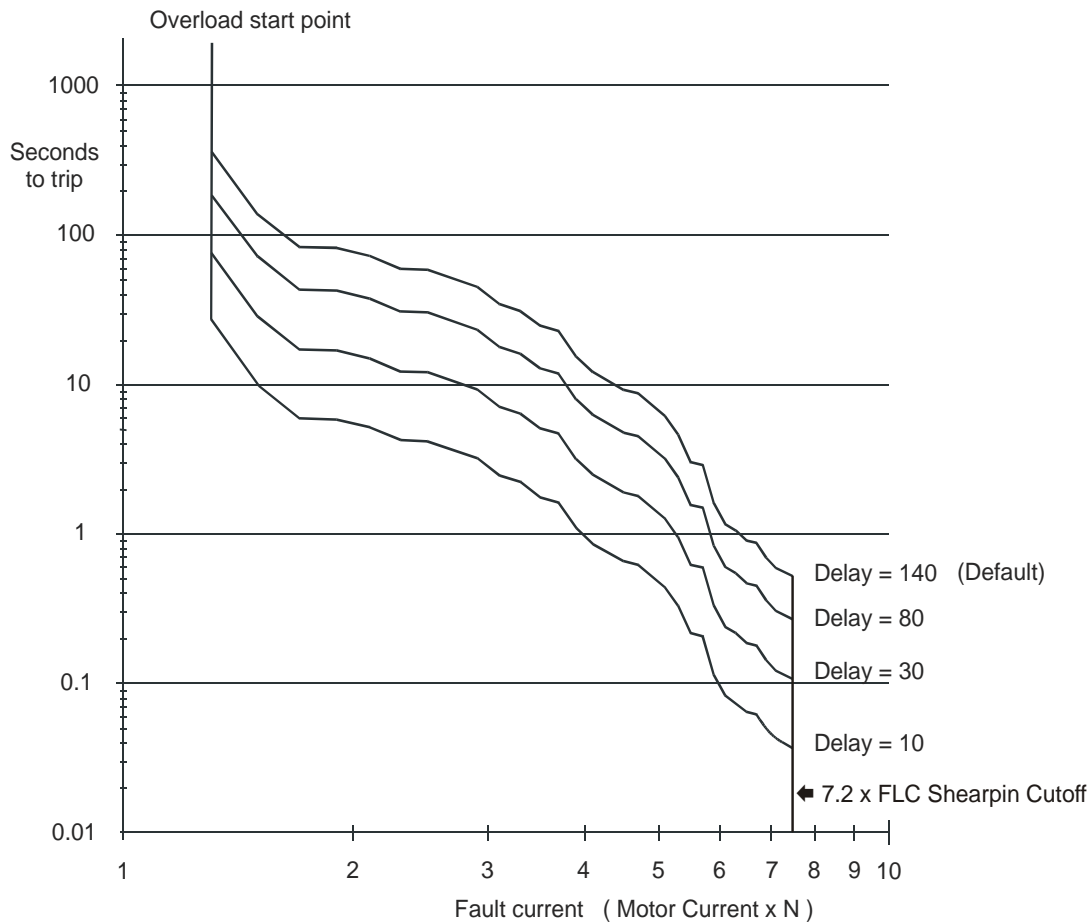

Figure 5.3.5c Shearpin

Overload Level - This parameter holds the level in Amps at which an Overload trip will start integrating (see the graph below). The default value for this parameter is $1.1 \times \text{Unit Full Load Current}$, but is expressed in Amps. **Special case:** if a load current exceeding $7.2 \times \text{FLC}$ occurs for longer than 60 mS, a Shearpin Trip is forced whenever the Overload is On, see section **5.3.11**.

Overload Delay - This parameter holds an arbitrary dimensionless number which slows down the integration of an Overload trip. The larger the value of the number stored here, the longer a given Overload will take to result in a trip. The default value of this parameter is 140.



- Notes**
 1. Delay = 'Overload Delay'.

Figure 5.3.5d Overload Trip Graph

5.3.6 Permanent Store Menu

Save Param - This item saves all the parameter settings to a permanent store. This means that if the control supply is removed from the main control board, the parameters will still remain stored and will be recalled the next time the unit boots up. See section 5.4.5.

Power on Param - This item recalls all the parameter settings from the last Save Param and loads the current parameters with these recalled values.

Default Params - This item loads all the parameters with their factory default values. The Starting parameter is set to Remote by this menu item, (P51, bit 7).

5.3.7 The Password Menu

Enter Password - This option enables the user to unlock a unit by entering previously set password. When the unit is locked the user can read all parameters as usual, but the user cannot write to any parameters. The unit **can** be started and stopped whilst it is locked. The default setting is for the unit to have **no** password set, (see section 5.4.10).

Change Password - This option enables the user to change a previously set password, to enter a password for the first time, or to clear the password. This last action is performed by changing the password to zero (0) and pressing Enter. This action clears any set password, but the control supply must be cycled or the unit reset by pressing the ▲ and ▼ buttons at the same time, after the password has been cleared (see section 5.4.9).

5.3.8 The Inputs Menu

Digital i/p 1 - This menu item gives access to the programming parameters for the first programmable input (see section 2.5.3 of Electrical Installation). A worked example showing how to program a digital input is given in section 5.5.4.

Digital i/p 2 (SFE3+) - This menu item gives access to the programming parameters for the second programmable input (see section 2.5.4 of Electrical Installation). A worked example showing how to program a digital input is given in section 5.5.6.

Digital i/p 3 (SFE3+) - This menu item gives access to the programming parameters for the third programmable input (see section 2.5.4 of Electrical Installation). A worked example showing how to program a digital input is given in section 5.5.5.

Temperature i/p - This menu item gives access the heatsink temperature in °C from a suitable temperature sensor (fitted at the factory). It is also possible to set the heatsink temperature above which the unit will not start, set via the Set Level submenu. This temperature sensor is not fitted as standard (normally a thermal switch is fitted) so this menu item will not normally be of any use to the customer.

4 - 20mA i/p (SFE3+) - This menu item gives access to the programming parameters for the 4 - 20mA input (see section 2.5.4 of Electrical Installation). A worked example showing how to program the 4 - 20mA input is given in section 5.5.8.

DC Input (SFE3+) - This menu item gives access to the programming parameters for the DC input (section 2.5.4 of Electrical Installation). A worked example showing how to program the DC input is given in section 5.5.9.

5.3.9 The Outputs Menu

- Led - This menu item is only of use to a customer who is using the Pot's and Switches software, which is covered by another publication (FD50E3 & FD50EJ).
- K1 - This menu item allows the customer to program the K1 relay (section 2.7.3 of Electrical Installation). At the bottom of the submenu is a list of programming short cuts which will set up the relay for the user. Below is a list of the short cuts with a description of when they energise the relay;
 - Run Relay - Usually for controlling the main contactor, energises whilst the unit is running.
 - Bypass Relay - Usually for controlling the bypass contactor, energises when the unit reaches TOR.
 - Alarm - Energises when an Alarm condition is present.
 - CurrentLimitng - Energises when the unit is current limiting.
 - OvldIntgrating - Energises when the SFE3's overload is integrating.
 - Stall - Energises when the motor is stalling.
 - Cooling - Energises when the SFE3 is cooling (start inhibited).
 - Enable Status - Energises when the SFE3 is enabled.

A worked example showing how to program a relay is given in section 5.4.11.

- K2 - This menu item allows the customer to program the K2 relay (section 2.7.3 of Electrical Installation). At the bottom of the submenu is a list of programming short cuts which will set up the relay for the user (see above). A worked example showing how to program a relay is given in section 5.4.11.

- K3 (SFE3+) - This menu item allows the customer to program the K3 relay (section 2.7.4 of Electrical Installation). At the bottom of the submenu is a list of programming short cuts which will set up the relay for the user (see above). A worked example showing how to program a relay is given in section 5.5.3.

- K4 (SFE3+) - This menu item allows the customer to program the K4 relay (section 2.7.4 of Electrical Installation). At the bottom of the submenu is a list of programming short cuts which will set up the relay for the user (see above). A worked example showing how to program a relay is given in section 5.5.9.

- Analogue o/p 1 (SFE3+) - This menu item allows the customer to program the first analogue output (section 2.7.4 of Electrical Installation). A worked example showing how to program an analogue output is given in section 5.5.10.

- Analogue o/p 2 (SFE3+) - This menu item allows the customer to program the second analogue output (section 2.7.4 of Electrical Installation). A worked example showing how to program an analogue output is given in section 5.5.10.

5.3.10 The Parameters Menu

This menu contains a number based, complete listing of all parameters, menu items and their values. Those parameters and menu items which can be written to, can be written to here as well as in the main text-based menu section. The parameters are listed in numerical order, and an explanation of what each parameter does, it's default value, units etc..., can be found in 'The_5MC_Parameter_List', a document on the website.

5.3.11 The Trips Menu

This menu holds all the parameters that are associated with control of the various trips

Trips - This sub menu accesses a trip history of the unit's last five trips. These trips are recorded automatically and need no intervention from the user. They are useful in fault-finding a unit.

- Trip-1 - This parameter records the trip number of the last recorded trip.
- Trip-2 - This parameter records the trip number of the second last recorded trip.
- Trip-3 - This parameter records the trip number of the third last recorded trip.
- Trip-4 - This parameter records the trip number of the fourth last recorded trip.
- Trip-5 - This parameter records the trip number of the fifth last recorded trip.

Note that most trips can be turned off, either via this menu, or through the **Trip Byte**, P127, or via the **Current** menu for the current related trips. Below is a list of each trip condition used by the SFE3. For each trip condition there is a small paragraph in the form;

Trip No
Trip Name
Explanation

01

Phase Loss

If one or more supply phases is missing when the unit is running a load (see **Note** section **5.3.4**, **Line Contactor**).

02

Too Hot

Fan cooled units are fitted with an internal thermal switch. The unit will trip if it detects an over temperature signal.

03

Comms

The unit will trip if communication fails between the user interface and the soft starter.

04 - 10

Thyristor Firing

These trips indicate that one or more of the thyristors is malfunctioning,

11

Low Current

The unit will trip if the unit's output current falls below a previously set level (**P28 Low Amps Level**) for a specified time (**P29 Low Amps Time**).

12

C/L Time Out

The unit will trip if during start-up the unit's output current reaches the Current Limit level (P30) for a time specified in Limit Time Out (P31).

13

Overload

The unit will trip if the output current exceeds the previously set Overload Level (P34), and will trip in a time governed by the size of the load current and a previously set arbitrary number, Overload Delay (P35), (see Figure 5.3.5d).

14

Shearpin

The unit will trip if the output current exceeds the previously set Shearpin Level (P32) for a time set in Shearpin Time (P33), (see Figure 5.2.3c).

15

Thermistor (SFE3-+)

Assuming that a thermistor has been fitted and connected to the Auxiliary Function Card, the unit will trip if the signal from the thermistor exceeds a value set by the manufacturer.

16

User

This is a trip which can be triggered by the customer via a variety of means, i.e. through the serial comms, or via a programmable input.

17

Comms Timeout

This trip occurs if there is no communication on the serial connection for more than five seconds.

Trip Sensitivity	-	See section 5.3.4
P126 Comms Trip	-	See section 5.3.4
Cooling	-	See section 5.3.4
Thermistor Trip	-	See section 5.3.4
C/L Timeout	-	See section 5.3.5
Low Current	-	See section 5.3.5
Shearpin	-	See section 5.3.5
Overload	-	This switches On and Off the Overload Trip, see section 5.3.5. Special case: if a load current exceeding 7.2 x FLC occurs for longer than 60 mS, a Shearpin Trip is forced <u>whenever</u> the Overload is On.
Sensing Signal	-	This menu item switches On and Off Trip 7. This may be useful if there is excessive noise on the supply causing spurious Trip 7 Sensing Signal trips.

5.4 Setup Examples

This section holds common programming examples that any customer might wish to use. They explain how to set up the SFE3 for common tasks. Further, more advanced examples are given in section 5.5.2 and following.

5.4.1 Enabling and Disabling the SFE3

In this software release, the SFE3 has an additional safety feature, the Enable/Disable parameter; the effect of this parameter is that the user cannot start the SFE3 (*running the motor*) without enabling the unit first.

Whenever the control supply to the SFE3 is turned on, the unit powers up in an enabled state. The display will tell the user if the unit is enabled - if it is enabled the display will look like this;

```
Stopped and ready
1:
```

or whether it is disabled, when the display will look like this;

```
Starter Disabled
1: ▼ To Enable
```

If the unit has been disabled, there are two ways to enable the unit; one by pressing the down button when presented with the `Start Disabled` screen above, and the second by following the instructions below.

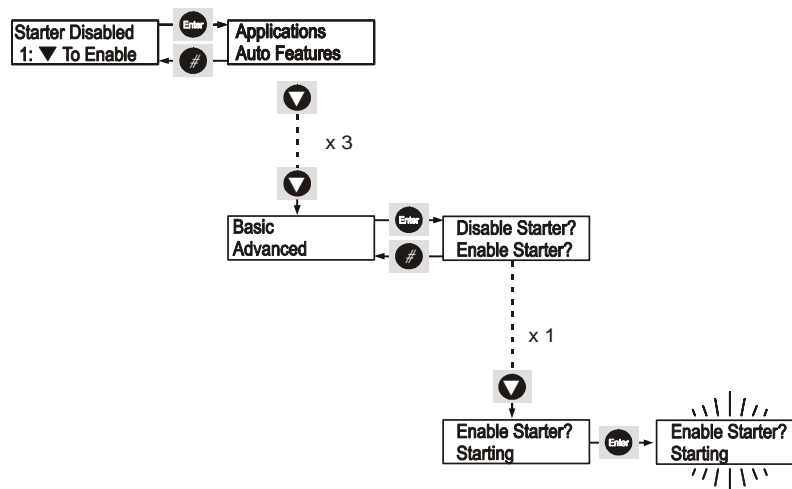

With `Starter Disabled` on the screen, press the `Enter` button once. Press the down button three times until `Basic` is on the top line of the display. Press the `Enter` button once, and with `Disable Starter?` showing press the down button once until `Enable Starter?` is on the top line of the display. Press the `Enter` button once and the display will flash once confirming the change

There is only one menu-driven way to disable the unit, and that follows the same procedure as above, except choosing `Disable Starter?` at the point where `Enable Starter?` was chosen.

There is another situation in which the user may need to disable the starter, that is when trying to write to a parameter to which write access is denied when the unit is enabled. Given such a situation (for instance, trying to load default parameters), the unit will ask the user whether he/she wishes to disable the starter. The user must then reply with the **Hash** (#) button to answer no, and the **Enter** button to answer yes. Note: if the SFE3 is disabled whilst running the load, it will stop running the load as soon as it is disabled.

To sum up, when the unit is disabled, all writeable parameters can be written to. When the unit is enabled, most, but NOT all, writeable parameters can be written to. Examples of parameters that cannot be written to whilst the unit is enabled, are the password and the currently loaded application: also default parameter values cannot be loaded whilst the unit is enabled.

5.4.2 How to read the Setup Examples

Each example consists of numbered step by step instructions which take the user through every action needed to complete the particular programming example. In addition there are diagrams which reference the text. The form these diagrams take are briefly explained below. (Note that the actual instructions in the diagrams in this section, 5.4.2, are for display only and are not intended to make sense as instructions.)

NB If the unit needs to be 'Disabled' (see section 5.4.1) before carrying out the instructions, the example will say so in it's introduction.

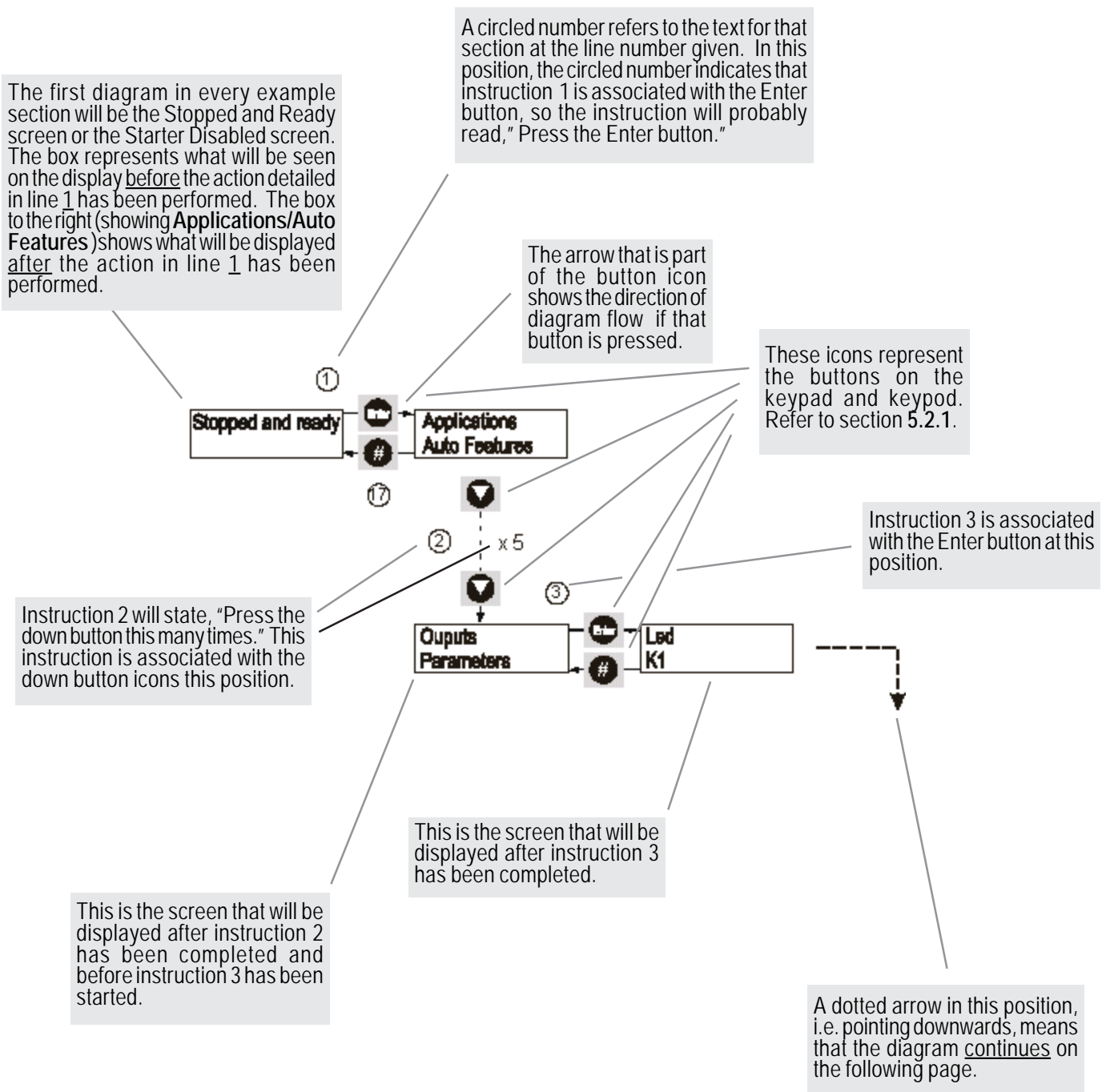

Press the # button to cancel the instruction, or the Enter button to confirm it.

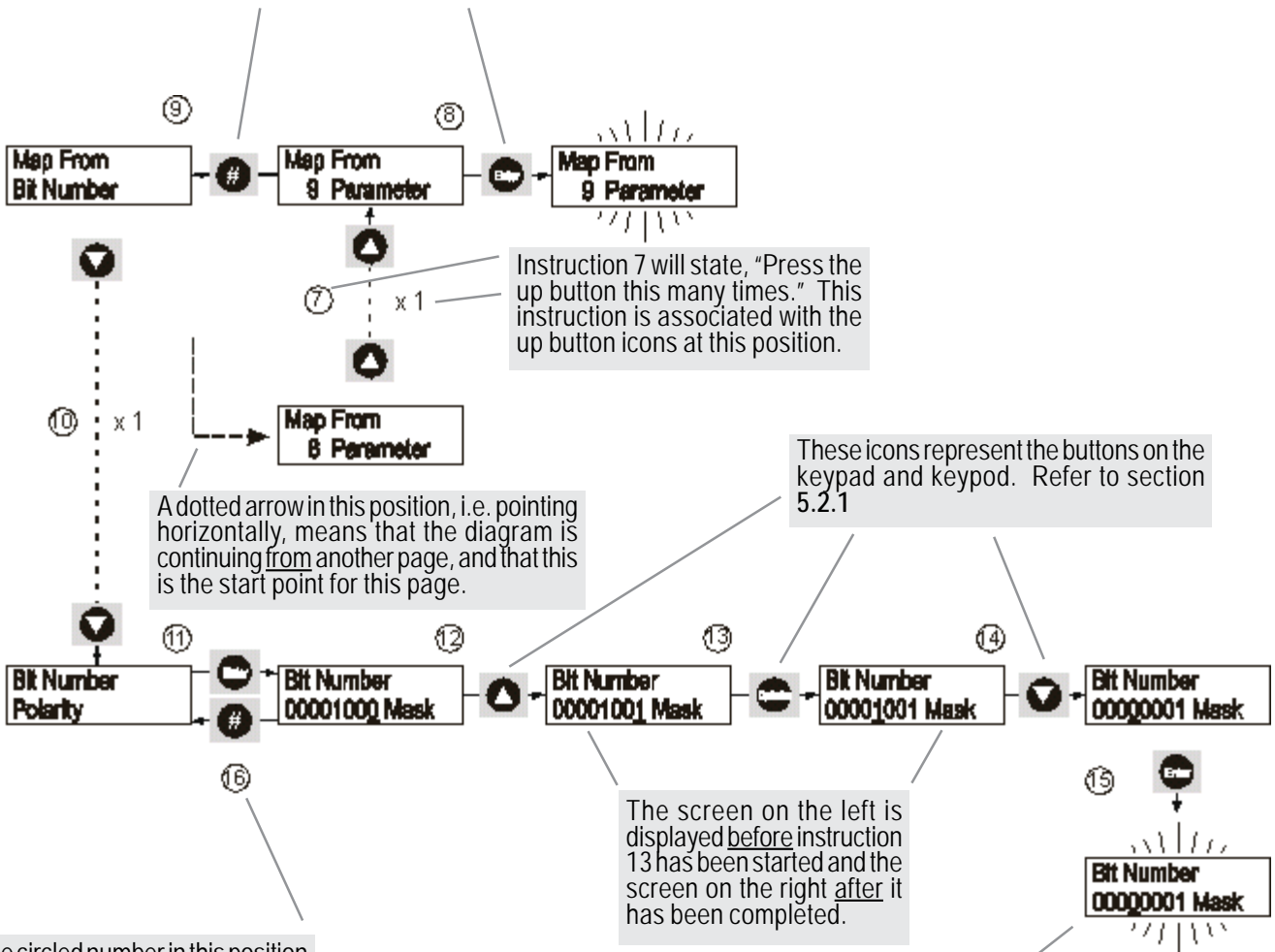

Instruction 7 will state, "Press the up button this many times." This instruction is associated with the up button icons at this position.

A dotted arrow in this position, i.e. pointing horizontally, means that the diagram is continuing from another page, and that this is the start point for this page.

These icons represent the buttons on the keypad and keypod. Refer to section 5.2.1

The screen on the left is displayed before instruction 13 has been started and the screen on the right after it has been completed.

When the circled number in this position it is associated with the lower (button) icon, the # button in this case.

This graphic represents the screen flashing, which it will do to confirm that an instruction or a change in value has been accepted.

Note; in the following examples, the **default** parameters are assumed to have been loaded before the start of the example, unless otherwise stated. This is to provide a common reference point for the instructions.

5.4.3 Loading the 'large pump' application into memory.

There are a number of pre-programmed applications included for speed and ease of setup. The parameters loaded by each selection characterise the standard setup of each particular application.

Note: This example assumes that the unit has been disabled (see section 5.4.1).

1. With `Starter Disabled` shown on the display, press the **Enter** button once.
2. With `Applications` shown on the top line of the display, press the **Enter** button once.
3. With `Settings` shown at the top of the display press **▼** button four times until `large pump` is shown at top of display.
4. Press **Enter** once to select `large pump`. The display will indicate which parameters are to be changed.
5. With the top line of the display showing `Send to store?`, press **Enter** to save the settings for a `large pump`. (If the **#** button is pressed instead at this point the unit will flash the message `Cancelled` three times). The display will flash the message `Storing` twice to indicate this has been done.
6. At any of the above stages pressing **#** will return the user to the previous menu. The unit will not start until the display indicates `Stopped and ready`.

Note. There is no need to save the changed parameter values as they are automatically saved at instruction 5.

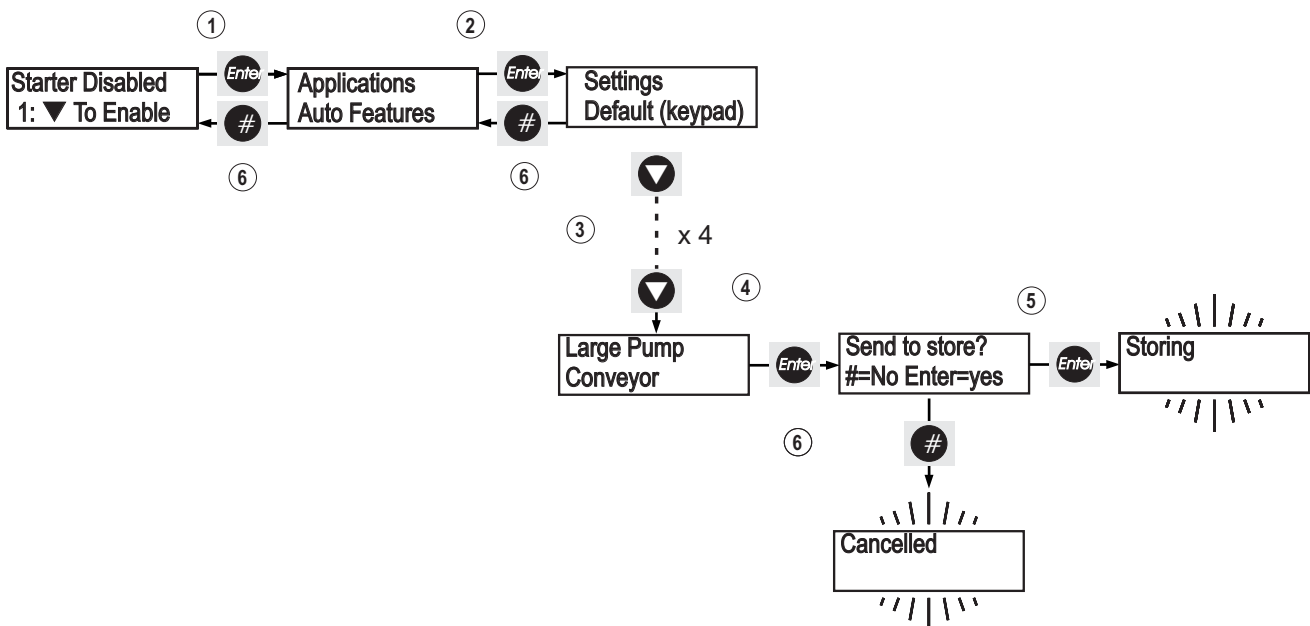

5.4.4 Changing from 'Keypad Starting' to 'Remote Starting'.

With 'Keypad Starting' set the unit is started from the keypad/keypod. Whilst 'Remote Starting' is set the unit is started with a start signal between **S0** and **S1**. 'Remote Starting' is the factory default value.

1. With *Stopped* and *ready* shown on the display, press the **Enter** once.
2. With *Applications* shown on the top line of the display press **▼** button twice until *Basic* is shown at top of display.
3. Press **Enter** once to select *Basic* menu.
4. With *Starting* shown at top of display press **Enter** once to select the *Starting* option.
5. With the display now showing *Starting* on the top line press **Enter** to toggle the bottom line of display from *Keypad Starting* to *Remote Starting*.
6. At any of the above stages pressing **#** will return the user to the previous menu.
7. The SFE3- will now start and stop remotely from the customer's switches (see section 2.3.1, of Electrical Installation) but will return to *Keypad Starting* if the control supply on terminals X1 and X2 is removed and a *Save Param* has not been performed. Alternatively, to return to *Keypad Starting*, repeat the above procedure and select *Keypad Starting* at step 5. **To keep the Remote starting setting after removal of the control supply, the settings must be permanently saved** (See section 5.4.5 below).

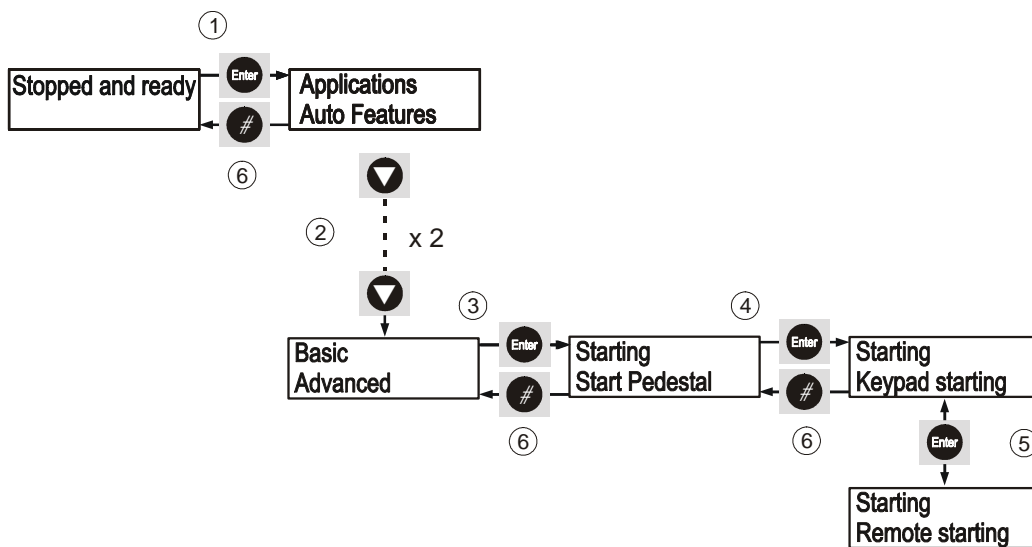

5.4.5 Permanently saving parameters set by the user.

To save parameters set by the customer, follow this procedure.

Note: This example assumes that the unit has been disabled (see section 5.4.1)

1. With `Starter Disabled` shown on the display, press **Enter** button once.
2. With `Applications` shown on the top line of the display press **▼** button four times until `Permanent Store` is shown at top of display.
3. Press **Enter** once to select `Permanent Store` menu.
4. With `Save Param` shown at top of display press **Enter** once to permanently save parameters. The display will flash twice to indicate this has been done.
5. At any of the above stages pressing **#** will return the user to the previous menu.

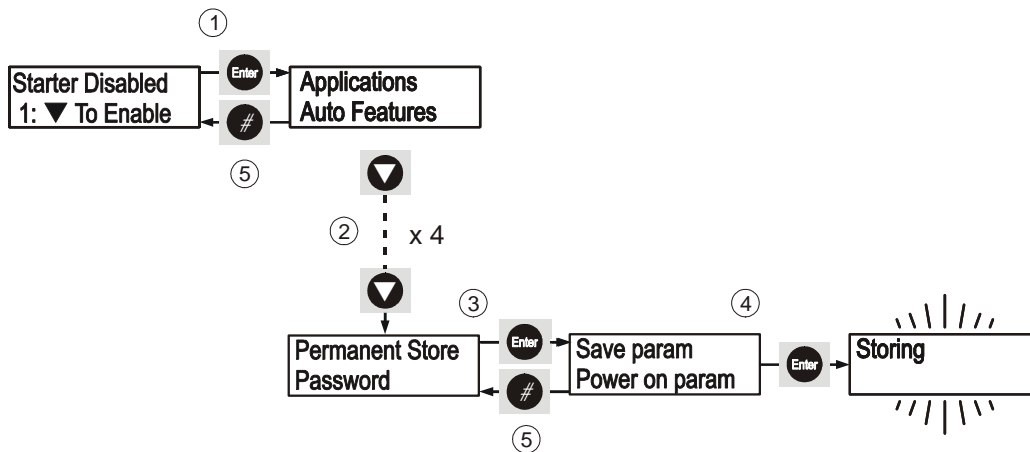

5.4.6 Loading the default parameter values with 'Keypad Starting' option.

Note: This example assumes that the unit has been disabled (see section 5.4.1).

1. With *Starter Disabled* shown on the display press the **Enter** button once.
2. With *Applications* shown on the top line of the display, press the **Enter** button again.
3. With *Settings* on the top line of the display, press the ▼ button until *Default (keypad)* is shown on the top line of the display.

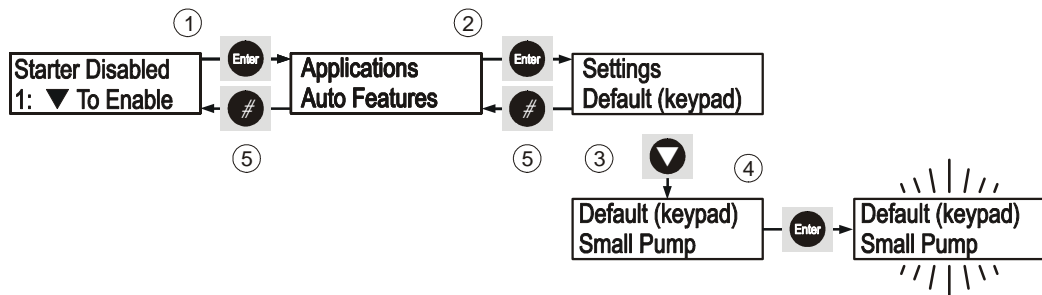

4. Press the **Enter** button once, and the display will flash three times, indicating that the default parameters (with keypad starting) have been loaded.
5. Press the # button twice to return to *Stopped* and *ready*.

Note; there is no need to save the parameters as they have automatically been saved when the system was reset to default values.

5.4.7 Loading the default parameter values with 'Remote Starting' option.

Note: This example assumes that the unit has been disabled (see section 5.4.1).

1. With `Stopped` and `ready` shown on the display press the **Enter** button once.
2. With `Applications` shown on the top line of the display, press the **▼** button until `Permanent Store` is on the top line of the display.
3. Press the **Enter** button once.
4. Press the **▼** button until `Default Param` is shown on the top line of the display.
5. Press the **Enter** button once, the display will flash indicating that default parameters have been loaded. The display will then show the selected starting option (`Remote`) and the selected protection option (`Full + Optimise`) before returning `Default Param` to the top line of the display.
6. Press the **#** button twice to return to `Stopped` and `ready`.

Note; there is no need to save the parameters as they have automatically been saved when the system was reset to default values.

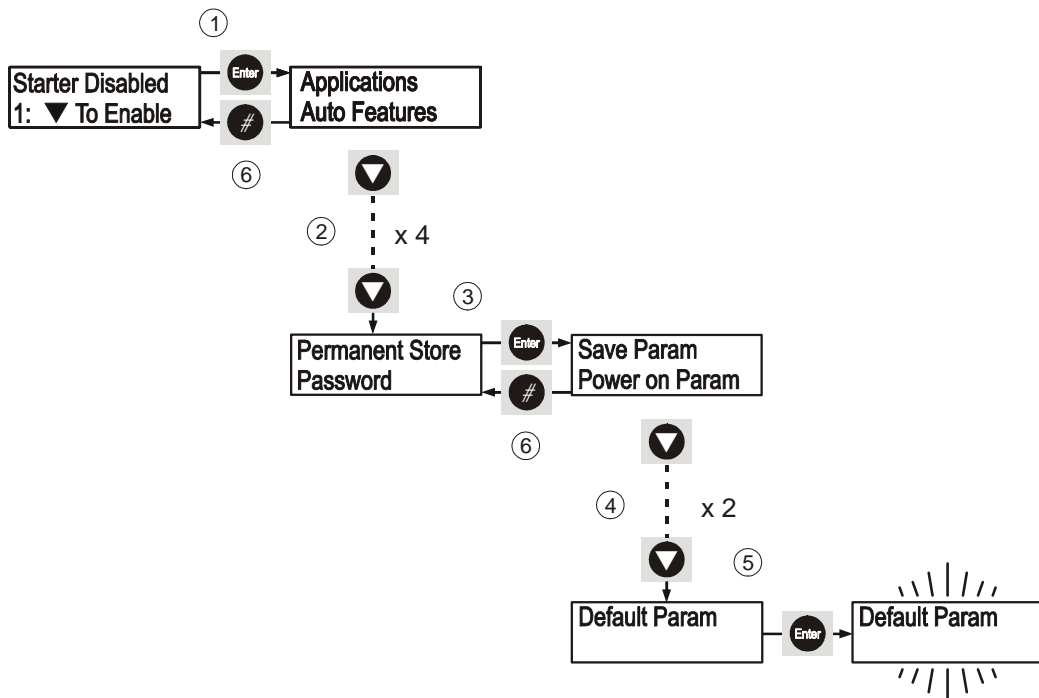

5.4.8 Viewing basic operating parameter values via the Settings menu option.

1. With `Starter Disabled` shown on the display press the **Enter** button once.
2. With `Applications` shown on the top line of the display, press the **Enter** button again.
3. With `Settings` on the top line of the display, press the **Enter** button and a downwards pointing arrow will appear on the right hand-side of the top line. Whilst this icon is displayed, the bottom line of the display will show a brief list of some of the basic parameters and their current values, including; the software version numbers; the starting option (`Remote` or `Keypad`); the current protection mode; the selected application (if none, the lower line of the display will remain blank for a moment); and whether any derating has been applied to the unit (if none, the lower line of the display will remain blank for a moment). When the arrow icon has disappeared, the report showing the basic parameters has finished and the user is the back in Menu Navigation mode, (see section 5.3.1).
4. This menu item is read-only.
5. Press the **#** button twice to return to `Stopped and ready`.

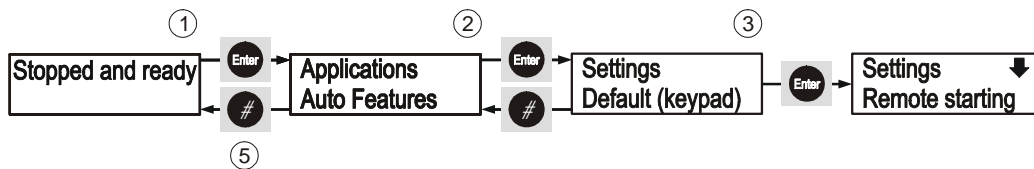

Note; as this menu item is read-only, it cannot be saved.

5.4.9 Changing a password.

Note: This example assumes that the unit has been disabled (see section 5.4.1) and if necessary has already been unlocked (see section 5.4.10).

1. With `Starter Disabled` displayed press the **Enter** button once.
2. With `Applications` shown on the top line of the display, press the **▼** button until `Password` takes it's place on the top line.
3. Press the **Enter** button once to select the `Password` menu.
4. Press the **▼** button once and `Change Password` will be displayed on the top line.
5. Press **Enter** once to select `Change Password`. A cursor will be visible on the bottom line of the display.
6. Use the **▲** or **▼** button to enter a new password number.
7. Press the **Enter** button once.

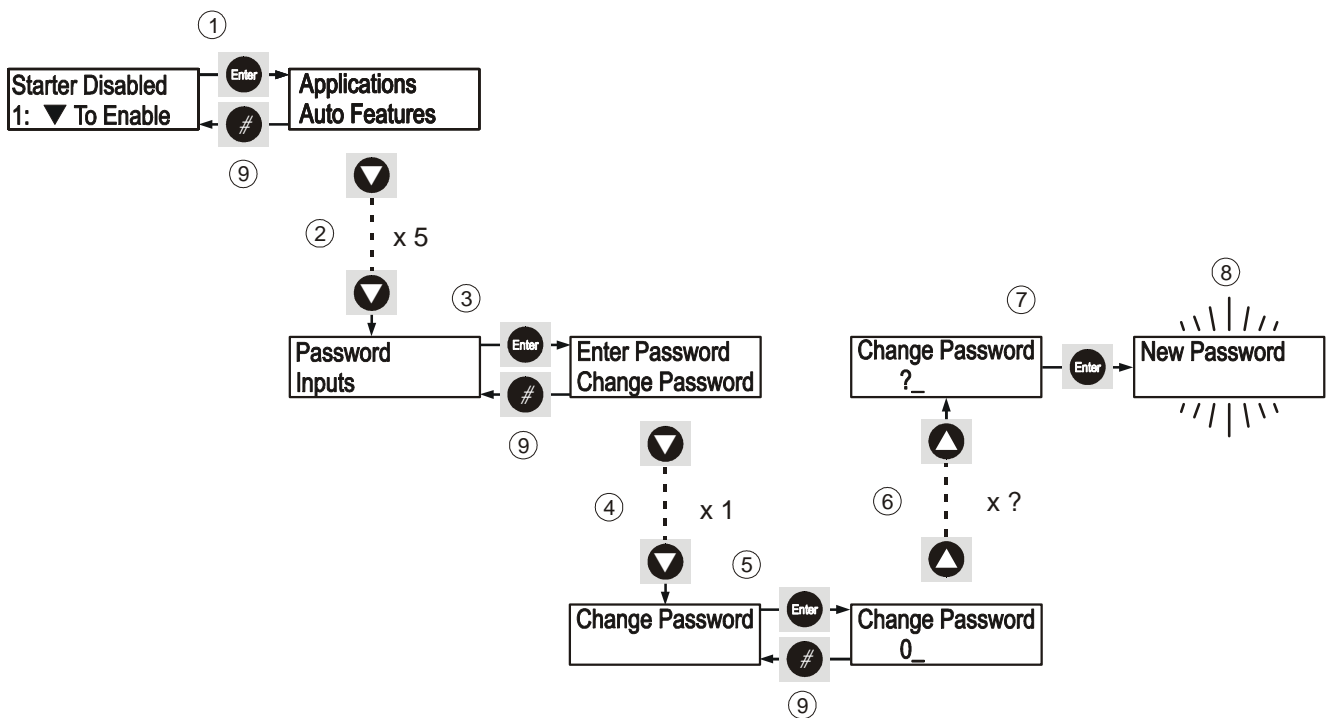

8. The display will flash `New Password!` twice to confirm that the change has been made.
9. Press the **#** button three times to return to `Starter Disabled`.

Notes

1. The unit must be unlocked (section 5.4.10) in order to change the password.
2. Setting the password to zero (0) deletes any set password and leaves the unit unlocked AFTER the control supply has been cycled or the keypad/keypod has been reset.
3. It is not necessary to save the password as it is stored automatically every time that it's value is changed.

5.4.10 Unlocking and locking the keypad.

1. With `Stopped` and `ready` displayed press the **Enter** button once.
2. With `Applications` shown on the top line of the display, press the **▼** button until `Password` takes it's place on the top line.
3. Press **Enter** once to select the `Password` menu.
4. Press **Enter** with `Enter Password` shown on the top line of the display. The unit will display its security status, `Locked` on the bottom line of the display. A cursor will also be visible on the bottom line of the display.
5. Use the **▲** or **▼** button to enter the password.
6. Press the **Enter** button once.
7. If the correct password has been entered, the unit will display it's security status, `Un-locked` on the bottom line of the display. To lock the unit again, simply use the **▲** and **▼** buttons to enter any value, apart from zero (0) and the password. Press the **Enter** button once and the display will now say that it is locked.
8. Press the **#** button three times to return to `Stopped` and `ready`.

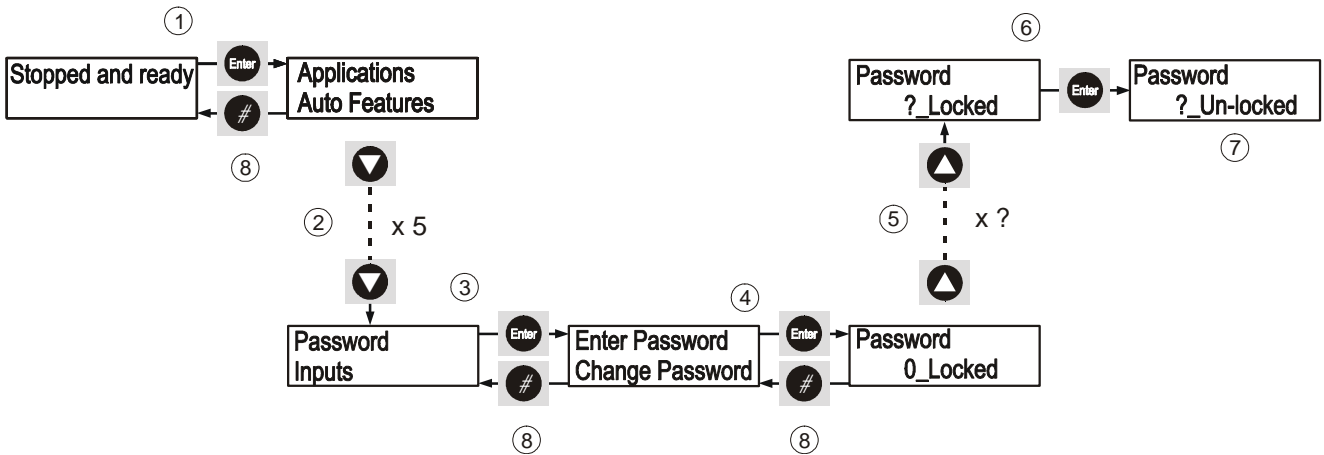

Note; if the control supply on an un-locked unit (i.e. the password has been set previously and then entered to unlock the unit) is cycled, upon reboot the unit will be in a locked state.

5.4.11 Using the pre-programmed relay options.

This example shows the user how to program any relay on the unit to via the pre-programmed options. The option shown in the example below is the Alarm, but the instructions apply equally for all of the pre-programmed relay options (see section 5.3.9), and for all of the relays - as they are all programmable.

1. With Stopped and ready shown on the display press the **Enter** button once.
2. With Applications shown on the top line of the display press the **▼** button until Outputs is shown at the top of the display.
3. Press **Enter** once to select the Outputs menu.
4. With Led on the top line of the display press the **▼** button until K2 is shown at the top of the display.
5. Press **Enter** once to select K2.
6. With Map From on the top line of the display press the **▼** button five (5) times until K=Alarm is shown on the top line of the display.
7. Press **Enter** once to select K=Alarm. The display will flash twice to confirm the user's selection.
8. Press the **#** button three (3) times to return to Stopped and ready.

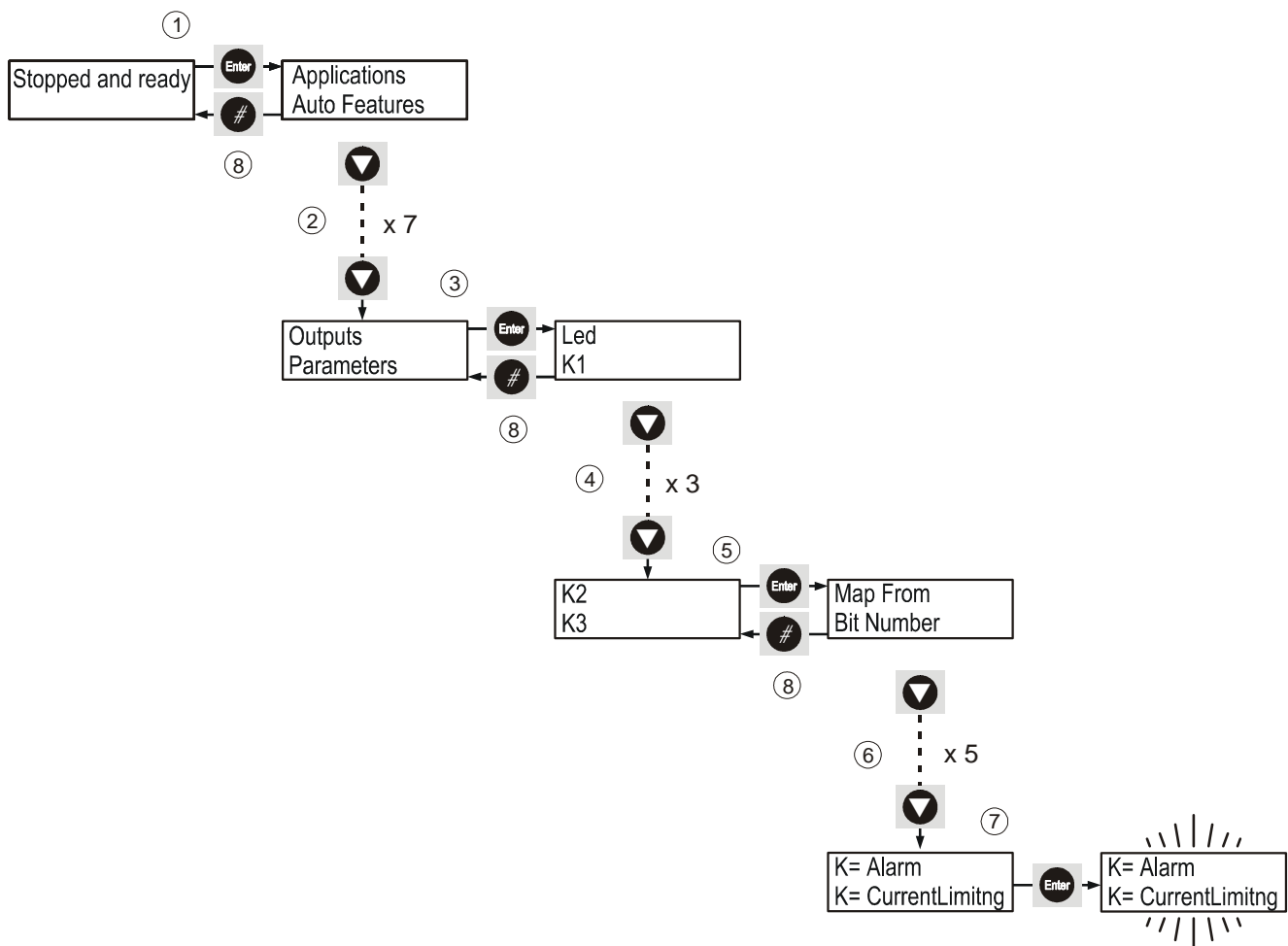

Please remember to keep the above settings they must be permanently saved. See section 5.4.5

5.4.12 Setting the Low Amps Level, and using the K2 relay to display the status of Low Current bit.

This example shows the user how to set the Low Amps Level, and how to monitor the status of the Low Current bit via the K2 relay (see section 5.3.5).

1. With Stopped and ready shown on the display press the **Enter** button once.
2. With Applications shown on the top line of the display press the **▼** button until Advanced is shown on the top line.
3. Press the **Enter** button once to select the Advanced menu.
4. With Current on the top line of the display, press **Enter** once to select the Current menu.
5. With Rated Current on the top line of the display press the **▼** button until Low Amps Level is shown on the top line.
6. With Low Amps Level on the top line of the display press **Enter** once.

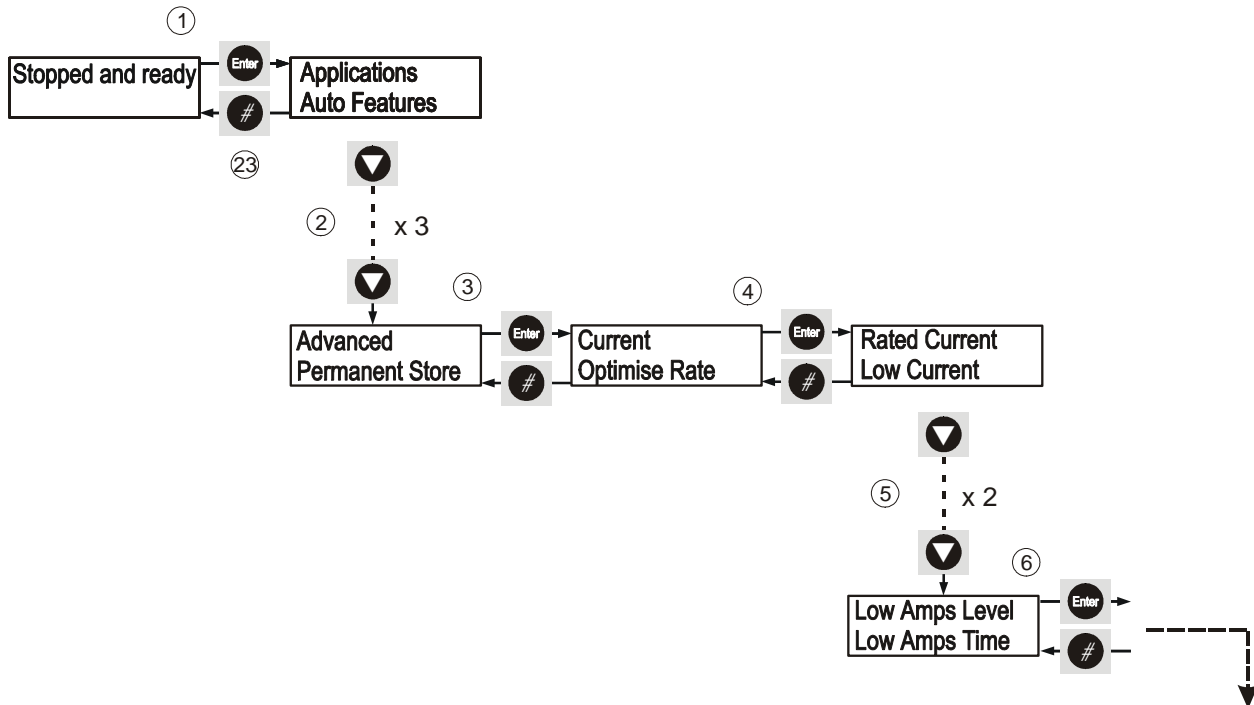

18. With `Map From` on the top line of the display, press the ▼ button once.
 19. Press the **Enter** button once to select `Bit Number`.
 20. Press the **Optimize** button three times to move the cursor to bit 3.
 21. Press the ▲ button to change the bit state to one (1). (This may not be necessary, bit 3 may already be a one). **Note:** only one bit in any relay bit mask may be set to a positive bit state (set to one (1)), at any one time. To turn off any other bits, simply use the **Optimize** button to navigate to the required bit, and press the ▼ button to change it's bit state to zero (0).
 22. Press the **Enter** button to confirm any changes, the display will flash.
 23. Press the # button four times to return to **Stopped and ready**.
- Please remember to keep the above settings they must be permanently saved. See section 5.4.5

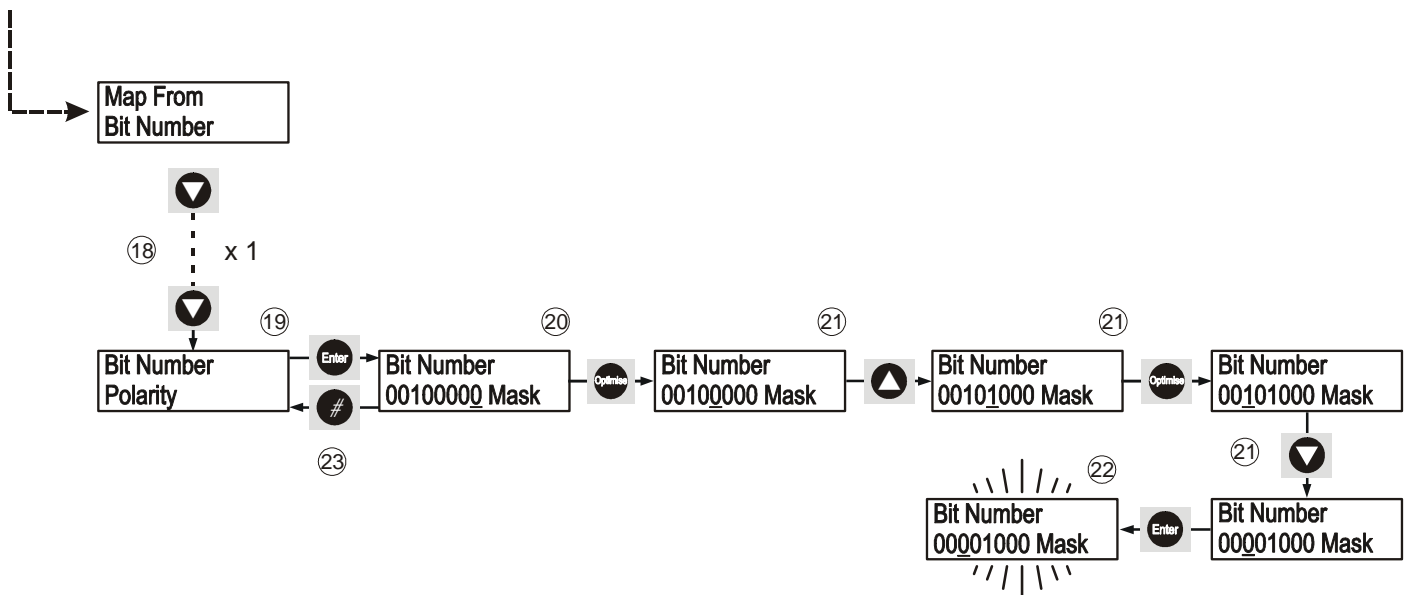

5.4.13 Using the K2 relay to mimic Programmable Input 1.

This example shows the user how energise a relay via the start signal.

1. With **Stopped** and **Ready** shown on the display press the **Enter** button once.
2. With **Applications** shown on the top line of the display press the **▼** button until **Outputs** is shown at the top of the display.
3. Press **Enter** once to select the **Outputs** menu.
4. With **Led** on the top line of the display press the **▼** button until **K2** is shown at the top of the display.
5. Press the **Enter** button once to select **K2**.
6. With **Map From** **From** on the top line of the display press **Enter** once.

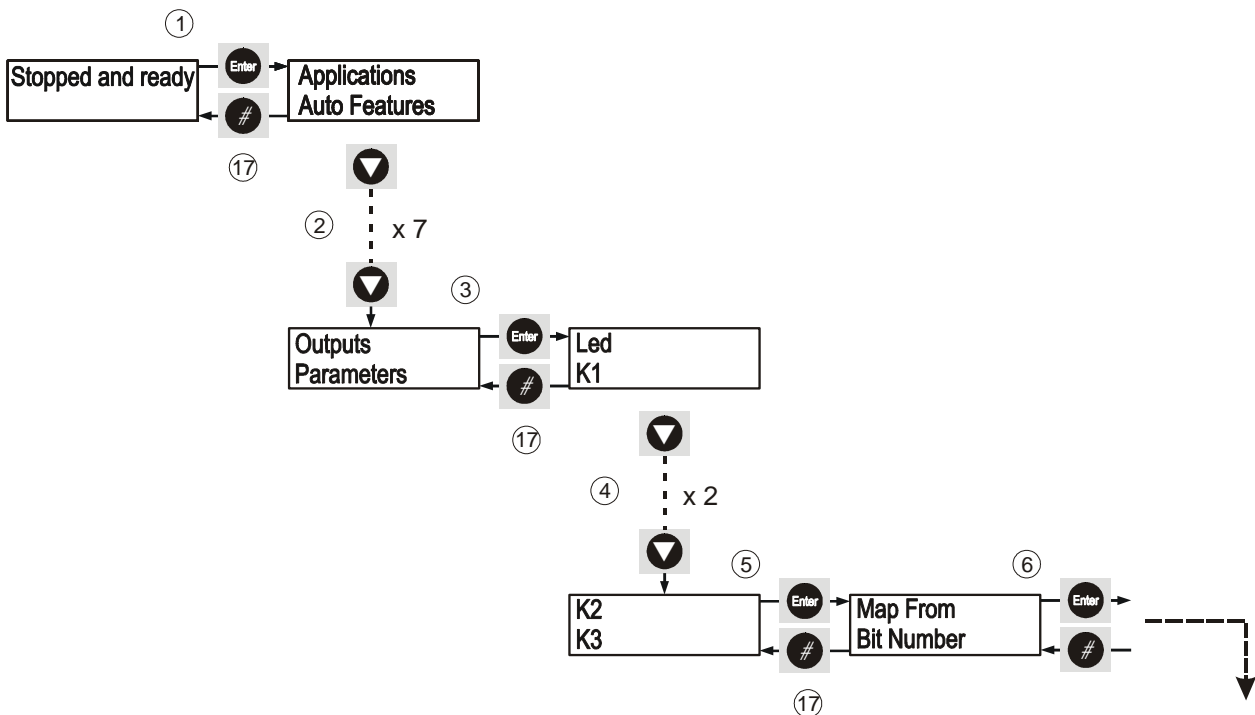

7. With 8 Parameter showing press the ▲ button until 10 Parameter is displayed.
8. Press **Enter** once to apply the change
9. Press # once to return to Map From.
10. With Map From on the top line of the display press ▼ button once until Bit Number is displayed.
11. Press **Enter** once to select Bit Number.
12. Press the **Optimize** button three times so the cursor is displayed on bit 3.
13. Press the ▼ button once to change the bit state to zero (0).
14. Press the **Optimize** button once so the cursor is displayed on bit 4.
15. Press the ▲ button once to change the bit state to one (1).
16. Press **Enter** once to accept the change.
17. Press # four times to return to Stopped and Ready.

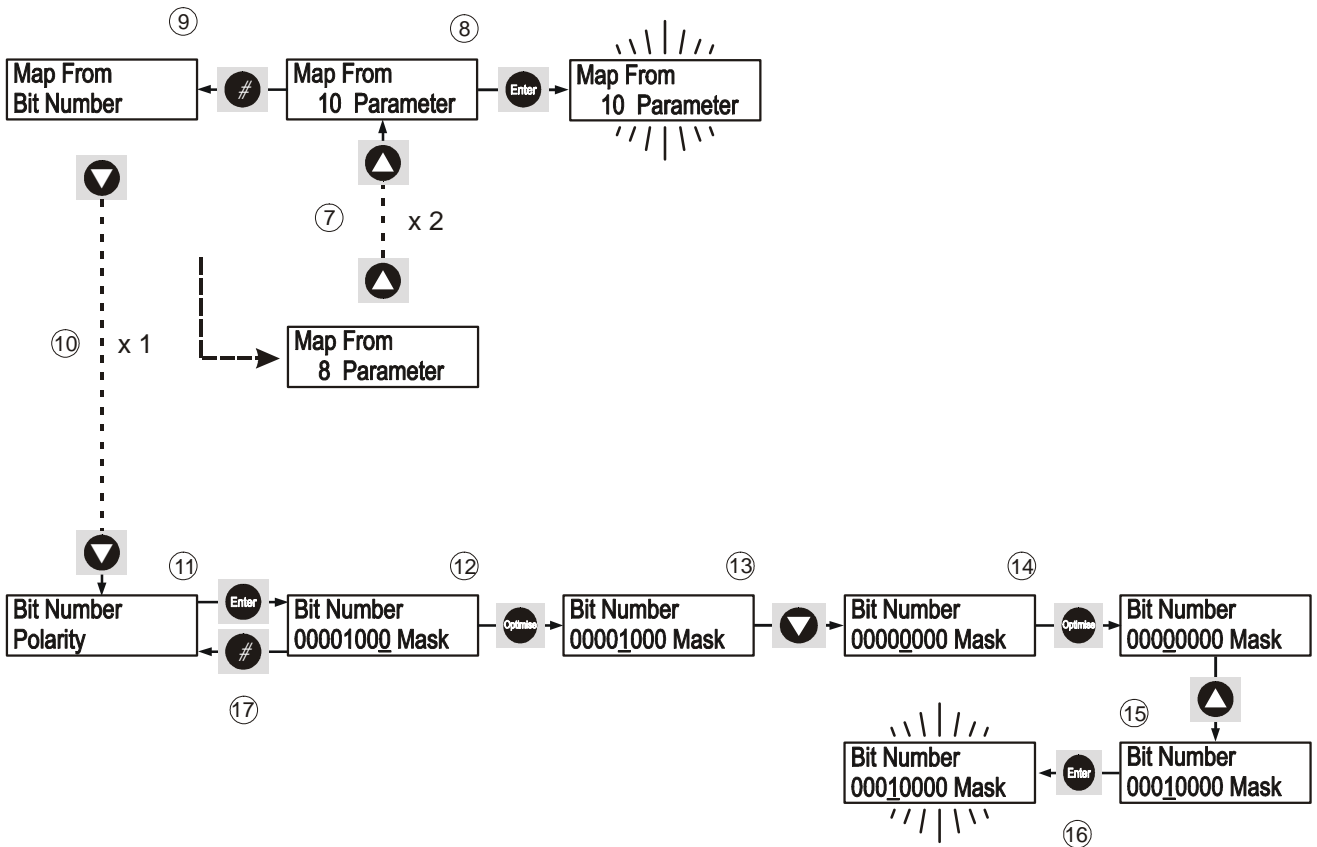

Please remember to keep the above settings they must be permanently saved. See section 5.4.5

5.5 Advanced Setup Examples

5.5.1 Using an Alternative Parameter Group

For applications that require the control of two motors or where the user requires different control characteristics for a single motor at different stages of the duty cycle, the SFE3 soft starter offers two parameter groups. The Primary parameter group holds the parameters considered necessary to motor starting and stopping, and it is this group that the starter defaults to. The Secondary parameter group is a mirror of the parameters in the first parameter group, but **NOT** necessarily a mirror of the values in the first parameter group. The parameters in each group are shown below.

Parameter	Primary Group	Secondary Group
Protection Mode	P7	P78
Start Pedestal	P11	P79
Start Time	P12	P80
Kick Pedestal	P13	P81
Kick Time	P14	P82
Dwell Time	P15	P83
Stop Pedestal	P16	P84
Stop Time	P17	P85
Auto Config	P18	P86
Low Current Level	P28	P87
Low Current Time	P29	P88
Current Limit Level	P30	P89
Current Limit Time	P31	P90
Shearpin Level	P32	P91
Shearpin Time	P33	P92
Overload Level	P34	P93
Overload Delay	P35	P94
User Flags 1	P51	P95
User Flags 2	P52	P96

Table 5.5.1; Primary and Secondary Parameter Groups

The Primary group parameters can also be changed via the menu structure, however the Secondary group parameters can only be changed via the dedicated parameter numbers. As a default the soft starter uses the Primary group of parameters. The user can select from between each group from either the keypad or using one of the programmable control inputs.

5.5.2 Changing the Parameter Group after the unit has passed Top of Ramp.

In this example the user is shown how to change parameter groups whilst running, if, for example, two overload values were required, one for starting and the other for running.

1. With Stopped and ready shown on the display press the **Enter** button once.
2. With Applications shown on the top line of the display press the **▼** button until Parameters is shown at the top of the display.
3. Press **Enter** once to select the Parameters menu.
4. With P1 - P20 shown on the display press the **▼** button until P81 - P100 is shown at the top of the display.
5. Press **Enter** to select P81 - P100.
6. With P81 Kick Ped 2 at the top of the display press the **▼** button until P97 U1 I/P srce is shown on the top line of the display.
7. Press **Enter** to select P97 U1 I/P srce.

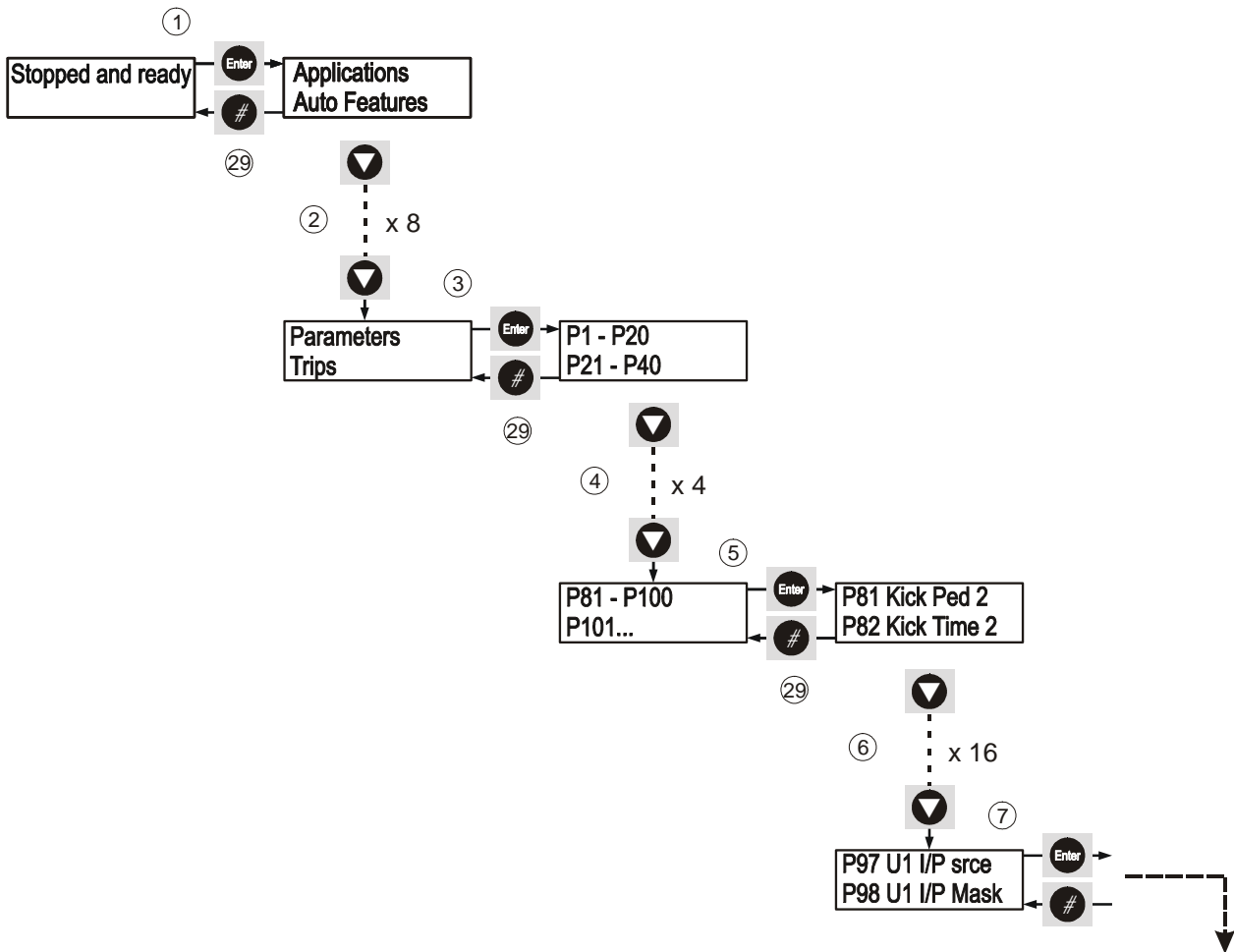

8. With 0 Parameter shown on the display press the ▲ button until 8 Parameter is displayed.
9. Press Enter once to accept the change.
10. Press # once to return to P97 U1 I/P srce.

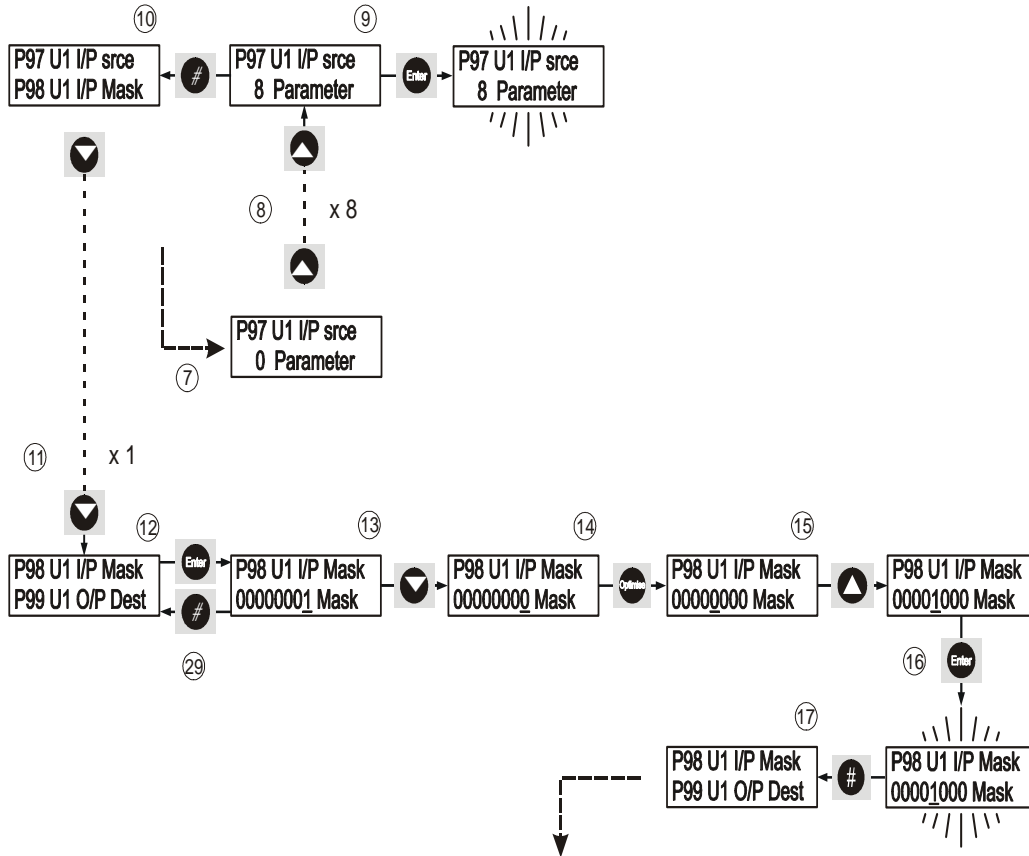

11. Press the ▼ button once until P98 U1 I/P Mask is shown at the top of the display.
12. Press Enter to select P98 U1 I/P Mask.
13. Press the Optimise button three times so that the cursor is displayed on bit 3.
14. Press the ▲ button once to change the bit state of bit 3 to one (1).
15. Press Enter once to confirm the changes.
16. Press # once to return to P98 U1 I/P Mask.

17. Press the ▼ button once so that P99 U1 O/P Dest is shown at the top of the display.
18. Press **Enter** to select P99 U1 O/P Dest.
19. With 0 Parameter shown on the display press the ▲ button until 52 Parameter is displayed.
20. Press **Enter** once to accept the change.
21. Press # once to return to P99 U1 O/P Dest.
22. Press ▼ once until P100 U1 O/P Mask is shown at the top of the display.
23. Press **Enter** to select P100 U1 O/P Mask.

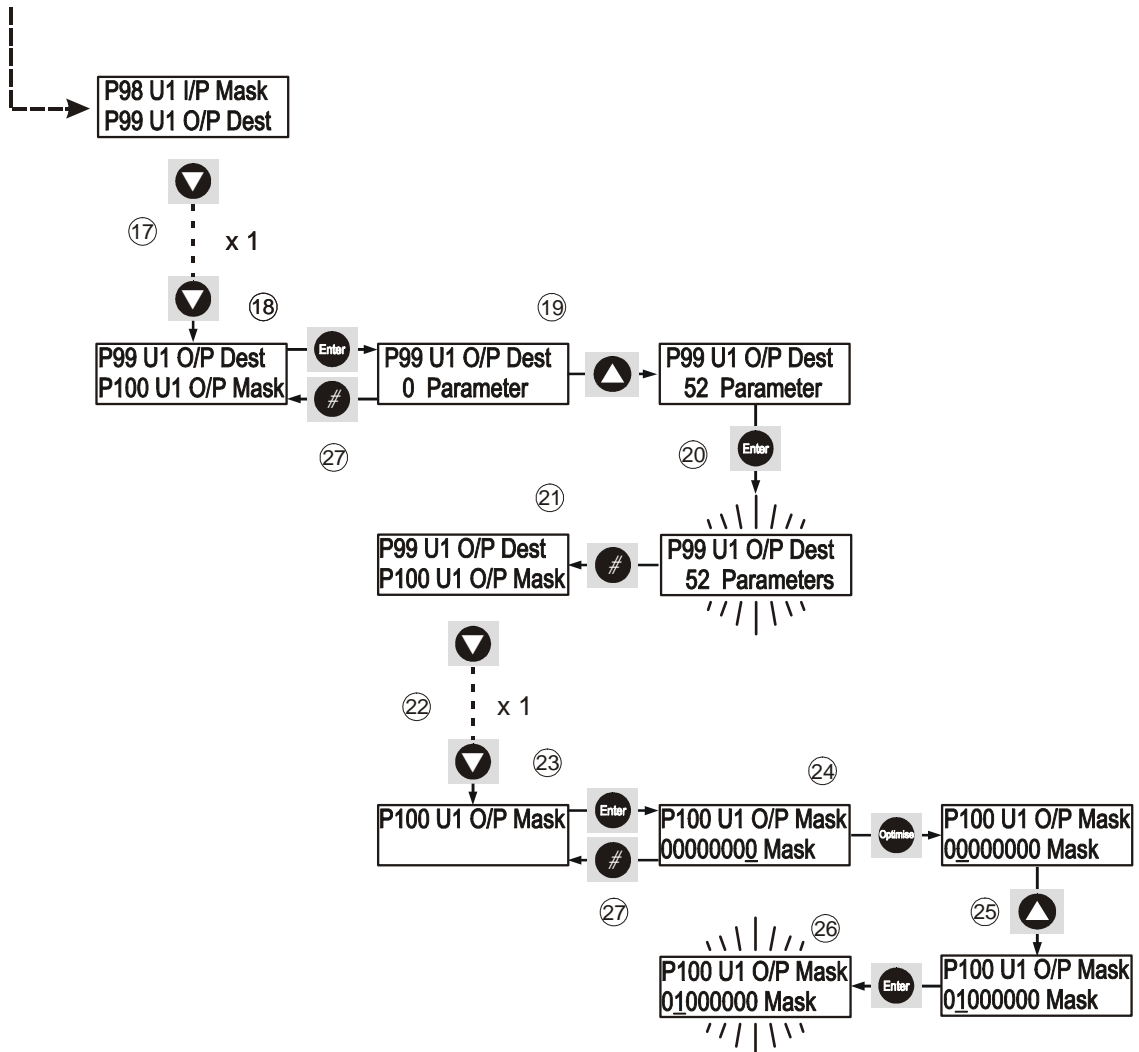

24. Press the **Optimise** button six times so that the cursor is displayed on bit 6.
 25. Press the ▲ button once to change the bit state of bit 6 to one (1).
 26. Press **Enter** once to accept the change.
 27. Press # four times to return to Stopped and Ready.
- Please remember to keep the above settings they must be permanently saved. See section 5.4.5

This page is left intentionally blank.

5.5.3 Using the K3 relay to indicate a Stall (applies to plus units only).

Here the user is shown how to output the unit's stall signal. This might be used by a customer to monitor a motor's stall status.

1. With `Stopped and Ready` shown on the display press **Enter** button once.
2. With `Applications` shown on the top line of the display press **▼** button until `Outputs` is shown at the top of the display.
3. Press **Enter** once to select the `Outputs` menu.
4. With `Led` on the top line of the display press **▼** button until `K3` is shown at the top of the display.
5. Press **Enter** once to select `K3`.
6. With `Map From` `From` on the top line of the display press **Enter** once.

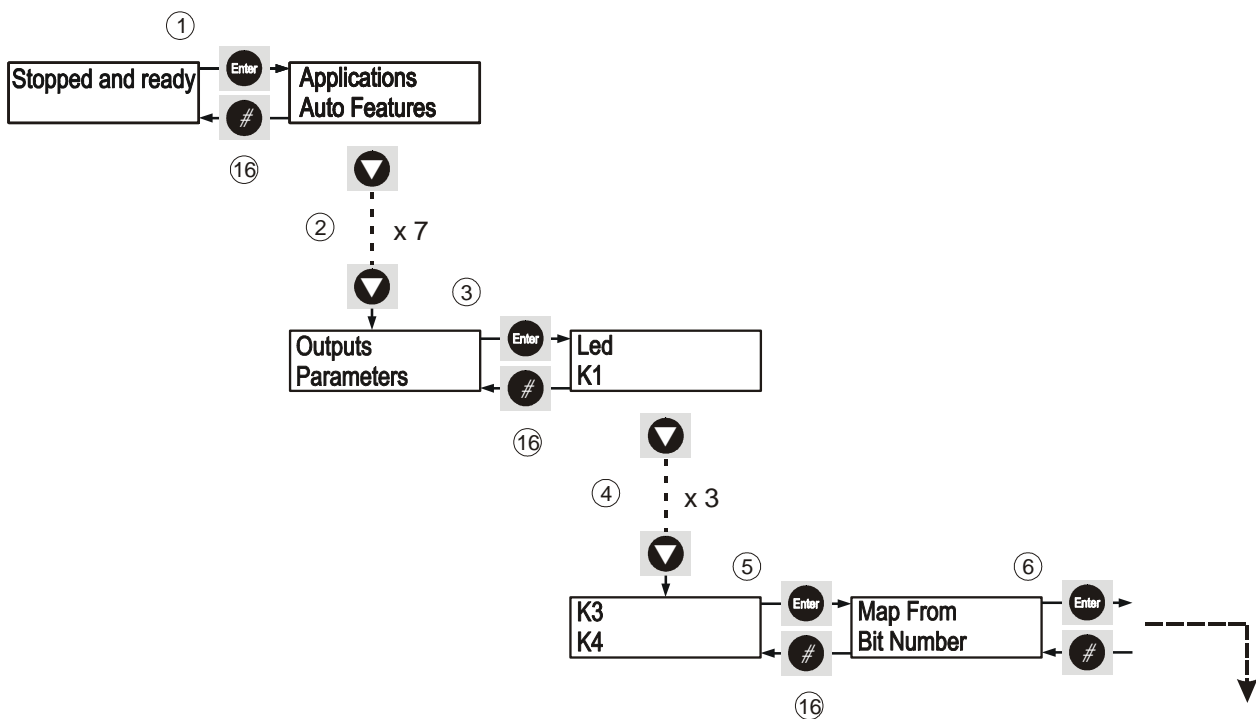

7. Check that 9 Parameter is showing - if it isn't press the ▼ button until it is displayed.
8. Press **Enter** once to apply any changes and the display will flash once to confirm the changes have been accepted.
9. Press # once to return to Map From.
10. With Map From on the top line of the display press the ▼ button once until Bit Number is displayed.
11. Press **Enter** once to select Bit Number.
12. With the cursor on the LSB press the ▼ button once to change the bit state to zero (0).
13. Press the **Optimize** button until the cursor is displayed on bit 2.
14. Press the ▲ button once to change the bit state to one (1).
15. Press **Enter** once to apply the change. The display will flash once to confirm the change has been accepted.
16. Press # four times to return to Stopped and ready.

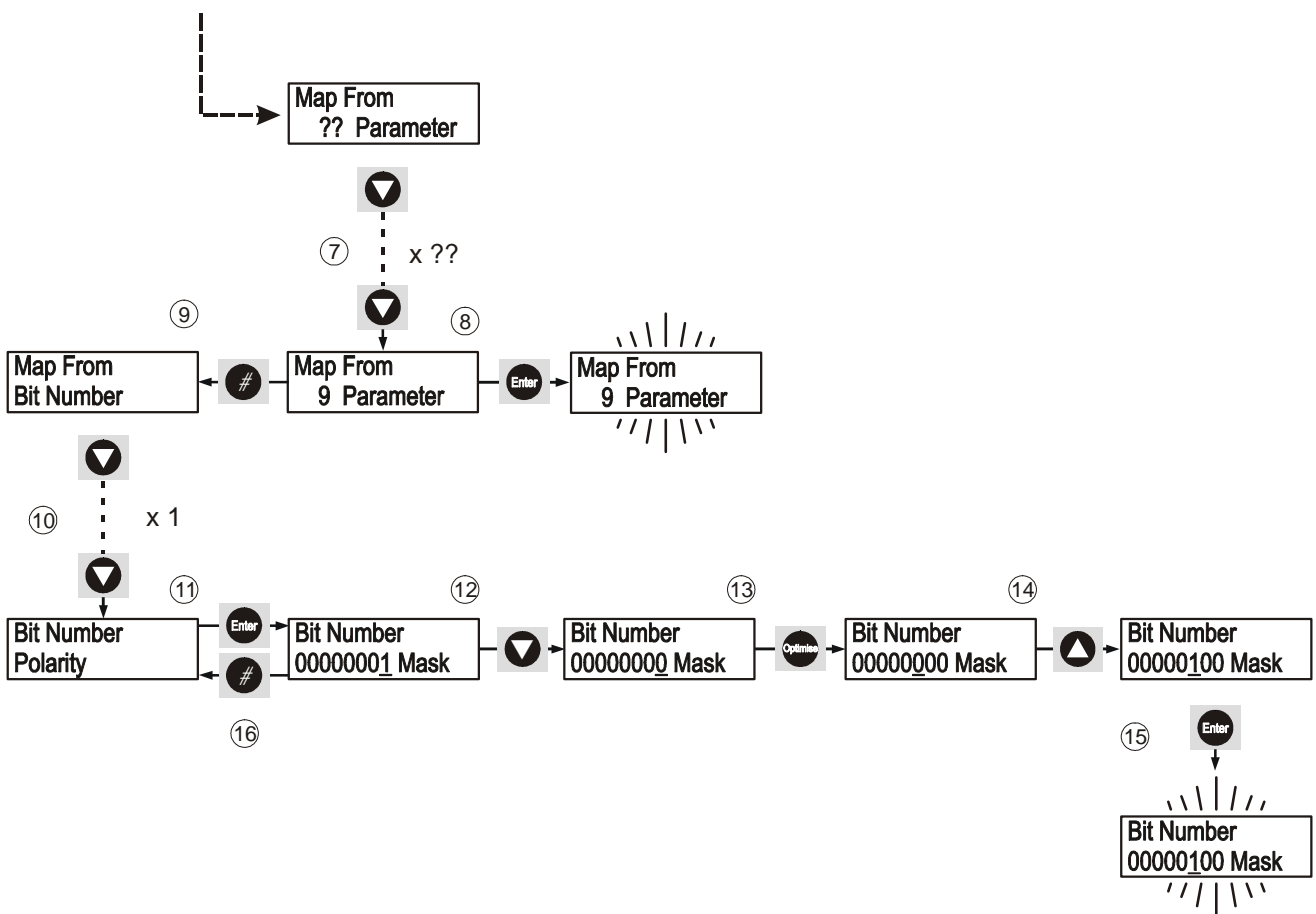

Please remember to keep the above settings they must be permanently saved. See section 5.4.5

5.5.4 Selecting Optimising with Programmable Input 1.

This example programs the **S1** input to turn the Optimising function Off and On. When the specified voltage is applied and removed to and from the S1 input, the energy optimising function is turned Off and On (note the inverse action - apply voltage = Optimising Off).

1. With Stopped and Ready shown on the display press **Enter** button once.
2. With Applications shown on the top line of the display press **▼** button until Inputs is shown at the top of the display.
3. Press **Enter** once to select the Inputs menu.
4. With Digital i/p 1 on the top line of the display press **Enter** once.
5. With Map To on the top line of the display press **Enter** once.
6. With 52 Parameter showing press the **▼** button until 7 Parameter is displayed.
7. Press **Enter** once to accept the change.
8. Press **#** once to return to Map To.

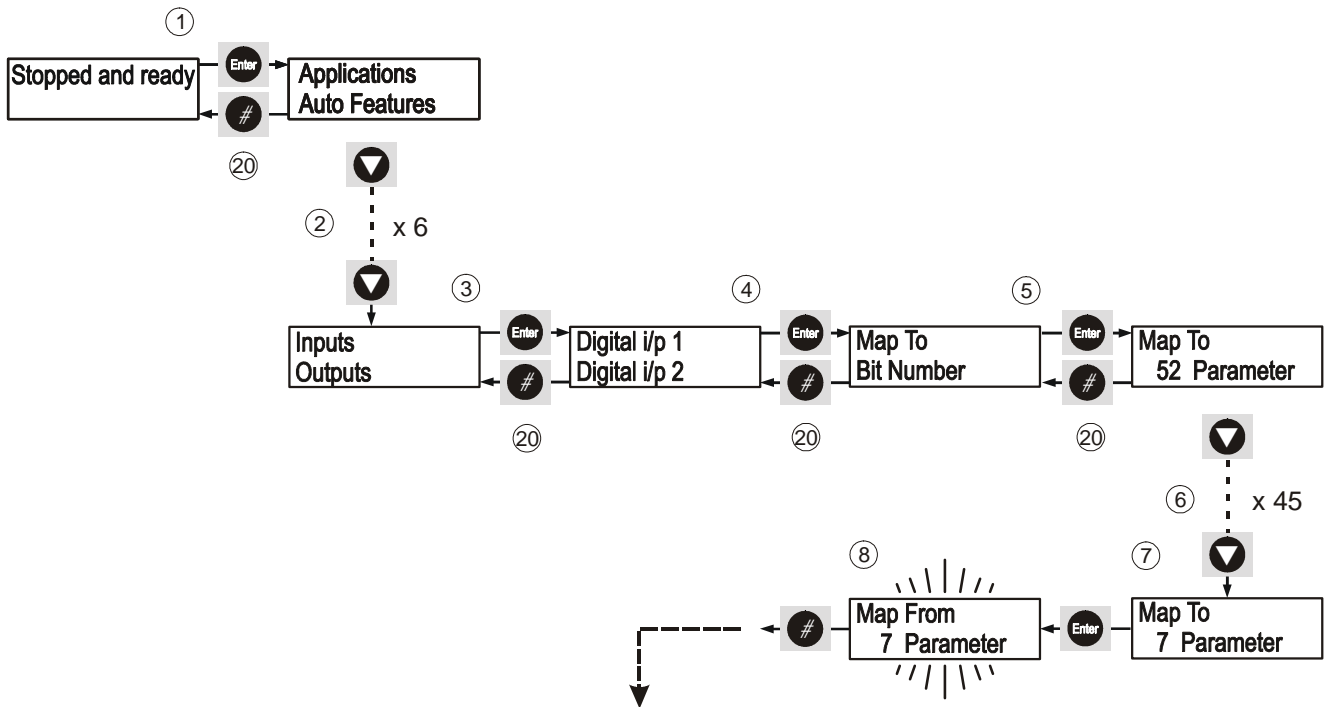

9. With `Map To` on the top line of the display press the **▼** button once until `Bit Number` is displayed.
10. Press **Enter** once to select `Bit Number`.
11. Press the **Optimize** button four times so that the cursor moves to bit 4.
12. Press the **▼** button once to change the bit state of bit 4 to zero (0).
13. Press the **Optimize** button three times so the cursor moves to bit 7.
14. Press the **▲** button once to change the bit state of bit 7 to one (1).
15. Press **Enter** once to accept the change. The display will flash once to confirm the change has been accepted.

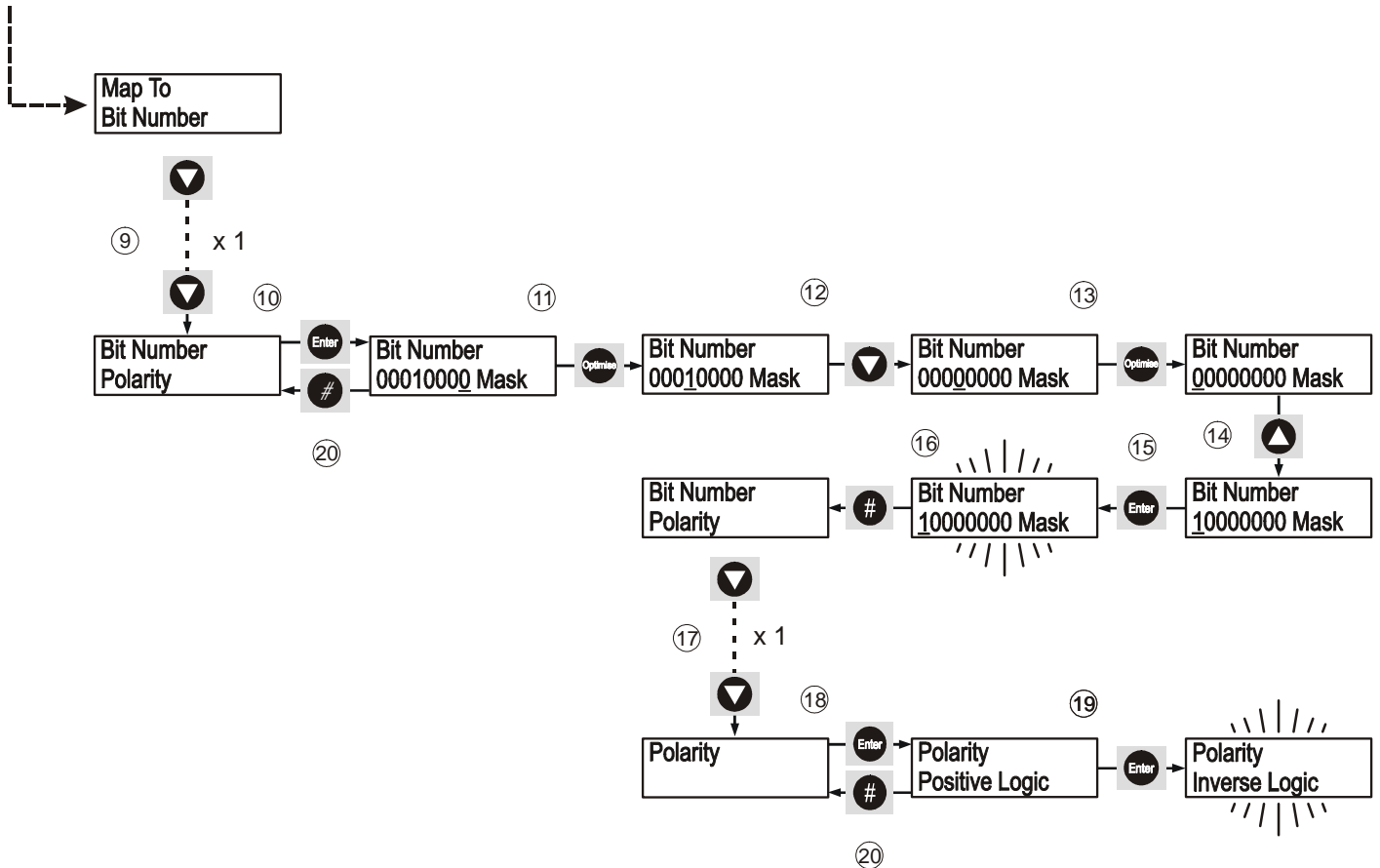

16. Press **#** once to return to `Bit Number`.
 17. With `Bit Number` on the top line of the display press the **▼** button once until `Polarity` is displayed on the top line.
 18. Press **Enter** once to select `Polarity`.
 19. With `Positive logic` displayed press **Enter** once to change to `Inverse logic`. The display will flash once to confirm the change has been accepted.
 20. Press **#** four times to return to `Stopped and ready`.
- Please remember to keep the above settings they must be permanently saved. See section **5.4.5**

5.5.5 Selecting a ‘Kick’ Start with Programmable Input 3, (applies to plus units only).

If the start-up characteristics of the load vary, i.e. ‘sticky’ and non-sticky, the user will be able to use the input to select a kick start for a ‘sticky’ load.

1. With Stopped and Ready shown on the display press **Enter** button once.
2. With Applications shown on the top line of the display press the **▼** button until Inputs is shown at the top of the display.
3. Press **Enter** once to select the Inputs menu.
4. With Digital i/p 1 on the top line of the display press the **▼** button until Digital i/p 3 is displayed.
5. With Digital i/p 3 on the top line of the display press **Enter** once.
6. With Map To on the top line of the display press **Enter** once.
7. With 0 Parameter showing press the **▲** button until 51 Parameter is displayed.
8. Press **Enter** once to accept the change.
9. Press # once to return to Map To.

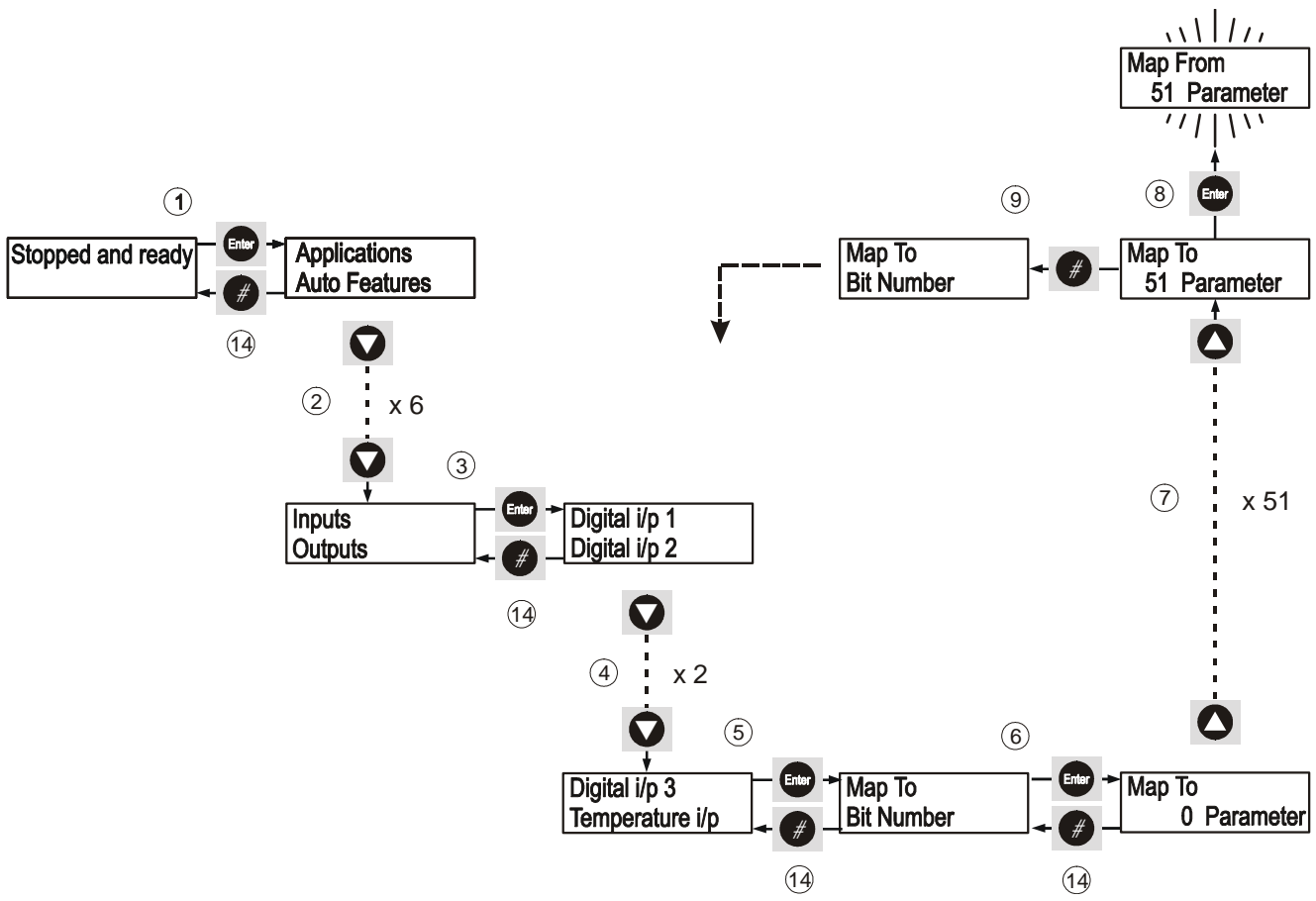

10. With `Map To Bit Number` on the top line of the display press **▼** button once until `Bit Number` is displayed.
11. Press **Enter** once to select `Bit Number`.
12. Press the **▲** button once to change the bit state of the LSB to one (1).
13. Press **Enter** once to accept the change.
14. Press **#** four times to return to `Stopped and Ready`.

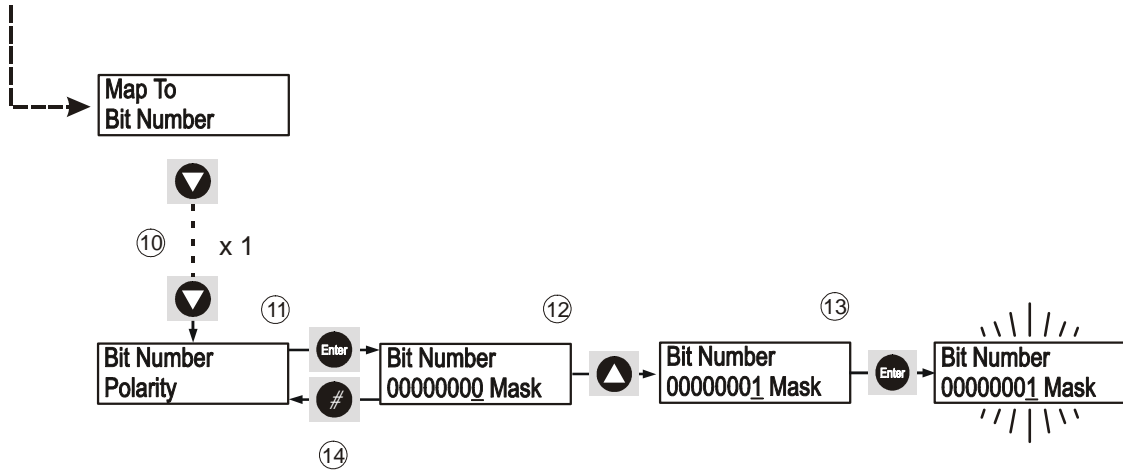

Please remember to keep the above settings they must be permanently saved. See section 5.4.5

5.5.6 Selecting a Parameter Group with Programmable Input 2, (applies to plus units only).

The user will be able to choose between two pre-programmed parameter groups, using the second programmable input. These parameter groups will have been pre-programmed by user to suit different load conditions.

1. With `Stopped` and `Ready` shown on the display press the **Enter** button once.
2. With `Applications` shown on the top line of the display press the **▼** button until `Inputs` is shown at the top of the display.
3. Press **Enter** once to select the `Inputs` menu.
4. With `Digital i/p 1` displayed press **▼** button until `Digital i/p 2` is displayed.
5. With `Digital i/p 2` on the top line of the display press **Enter** once.
6. With `Map To` on the top line of the display press **Enter** once.
7. With `0 Parameter` showing press the **▲** button until `52 Parameter` is displayed.
8. Press **Enter** once to accept the change. The display will flash once to confirm the change has been accepted.
9. Press **#** once to return to `Map To`.

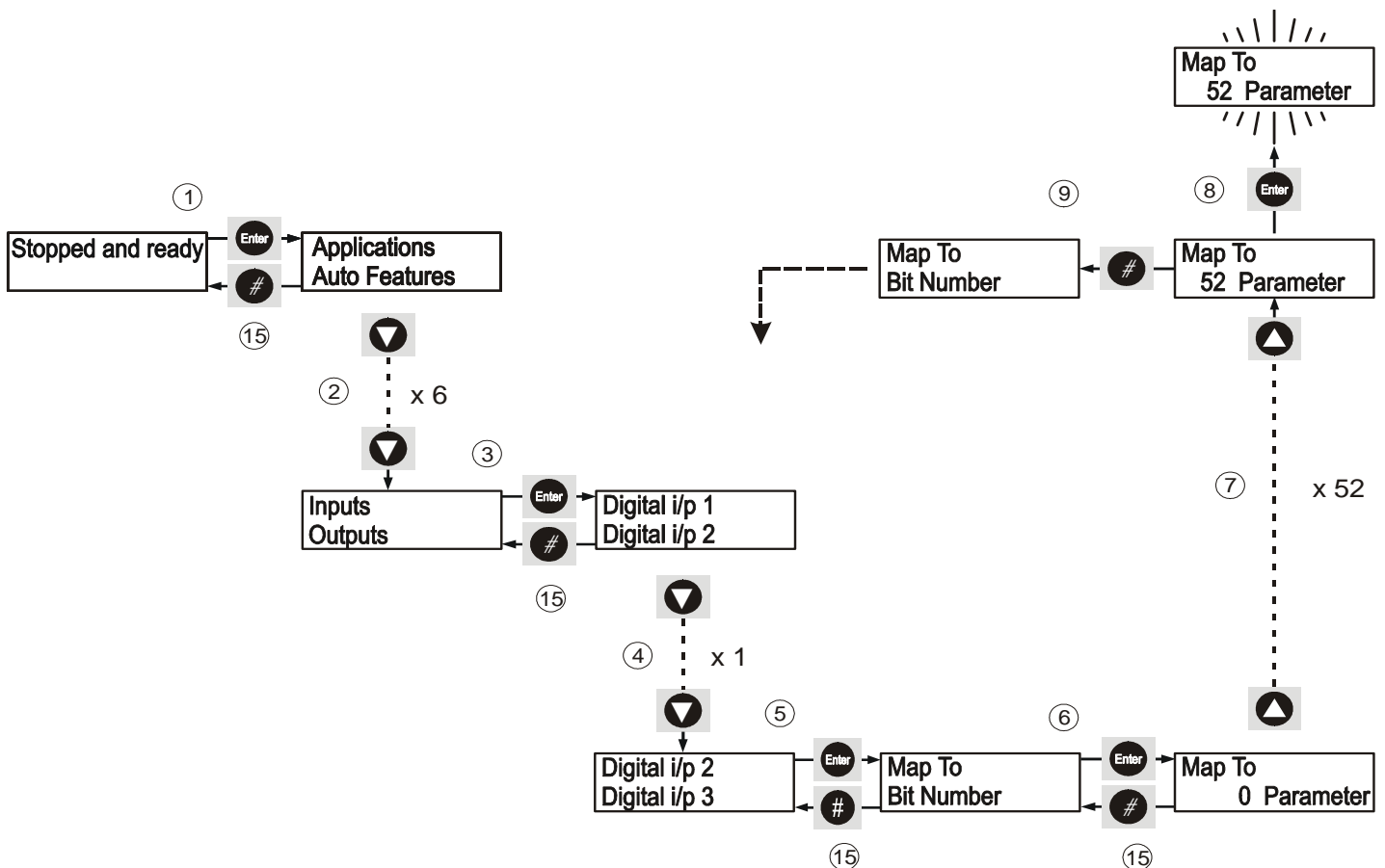

10. With **Map To** on the top line of the display press the **▼** button once until **Bit Number** is displayed.
11. Press **Enter** once to select **Bit Number**.
12. Press the **Optimize** button six times so the cursor is displayed on bit 6.
13. Press the **▲** button once to change the bit state of bit 6 to one (1).
14. Press **Enter** once to accept the change. The display will flash once to confirm the change has been accepted.
15. Press **#** four times to return to **Stopped and Ready**.

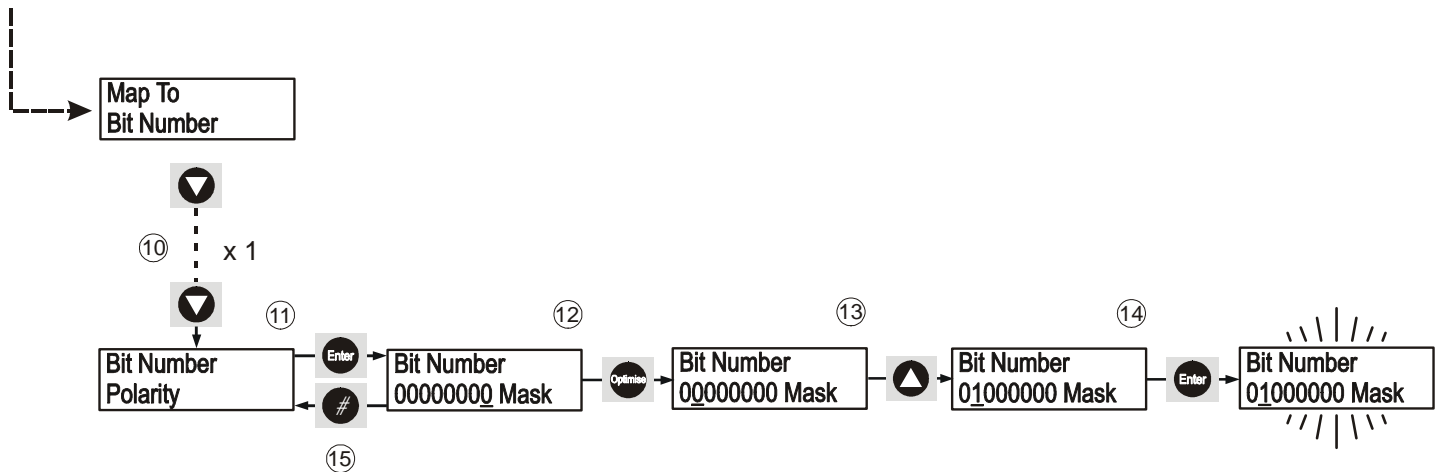

Please remember to keep the above settings they must be permanently saved. See section 5.4.5

5.5.7 Using the K3 relay to indicate the Main Contactor status, (applies to plus units only).

1. With `Stopped` and `Ready` shown on the display press the **Enter** button once.
2. With `Applications` shown on the top line of the display press the **▼** button until `Outputs` is shown at the top of the display.
3. Press **Enter** once to select the `Outputs` menu.
4. With `Led` on the top line of the display press the **▼** button until `K3` is shown at the top of the display.
5. Press **Enter** once to select `K3`.
6. With `Map From` `From` on the top line of the display press **Enter** once.

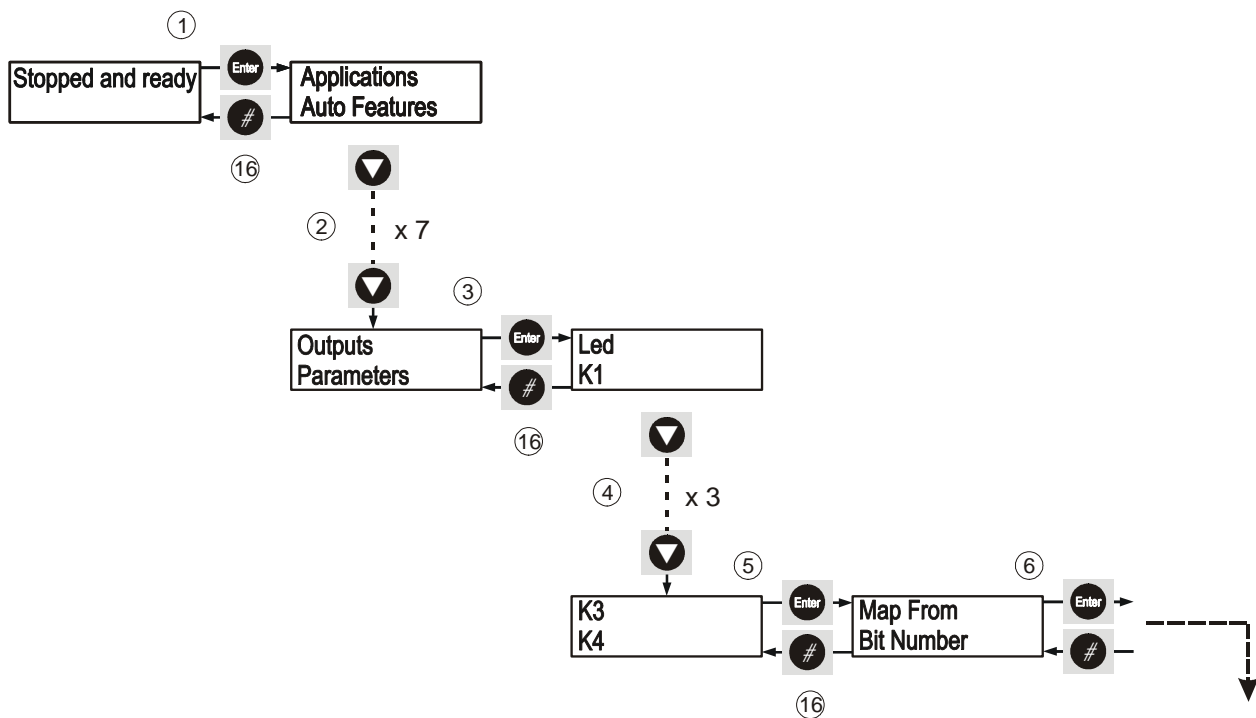

7. Press the ▲ or ▼ buttons until 52 Parameter is displayed on the bottom line of the display.
8. Press the Enter button once to apply the change. The display will flash once to confirm the change has been accepted.
9. Press # once to return to Map From.
10. With Map From on the top line of the display press the ▼ button once so that Bit Number is displayed on the top line.
11. Press Enter once to select Bit Number.
12. With the cursor on the LSB, Press the ▼ button once to change the bit state to zero (0).
13. Press the Optimize button until the cursor is displayed on bit five .
14. Press the ▲ button once to change the bit state to one (1).
15. Press Enter once to accept the change.
16. Press # four times to return to Stopped and Ready.

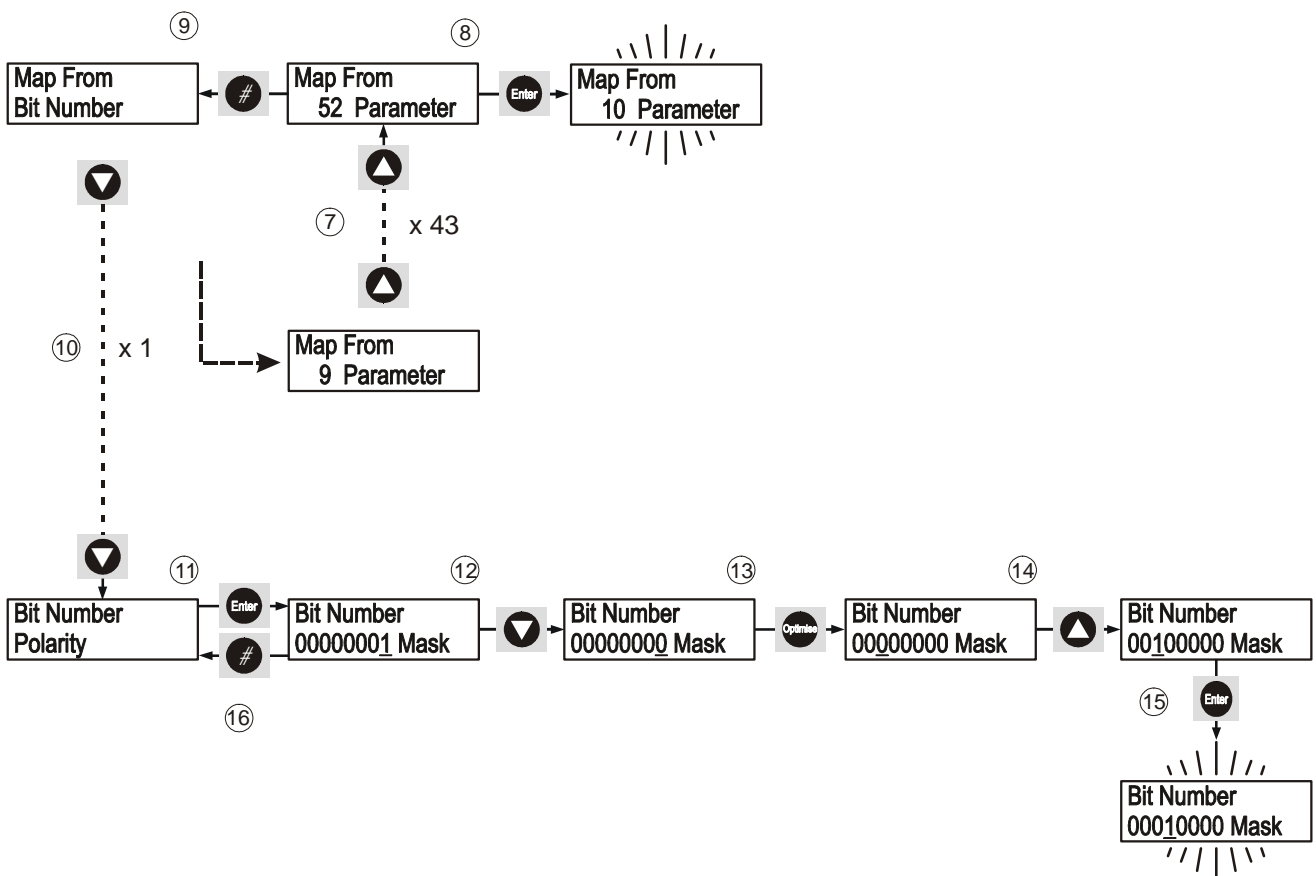

Please remember to keep the above settings they must be permanently saved. See section 5.4.5

5.5.8 Using the 4-20mA input to monitor a level, (applies to plus units only).

The unit can monitor the voltage level of the 4-20mA input and can be programmed to set a bit when that input level reaches a certain value. This bit can then be used to energise a relay, for example the K3 relay.

1. With Stopped and ready on the top line of the display, press **Enter**.
2. With Applications on the top line of the display, press the **▼** button until the display reaches Inputs.
3. With Inputs on the top line, press the **Enter** button.
4. Press the **▼** button until 4-20mA i/p is on the top line of the display.

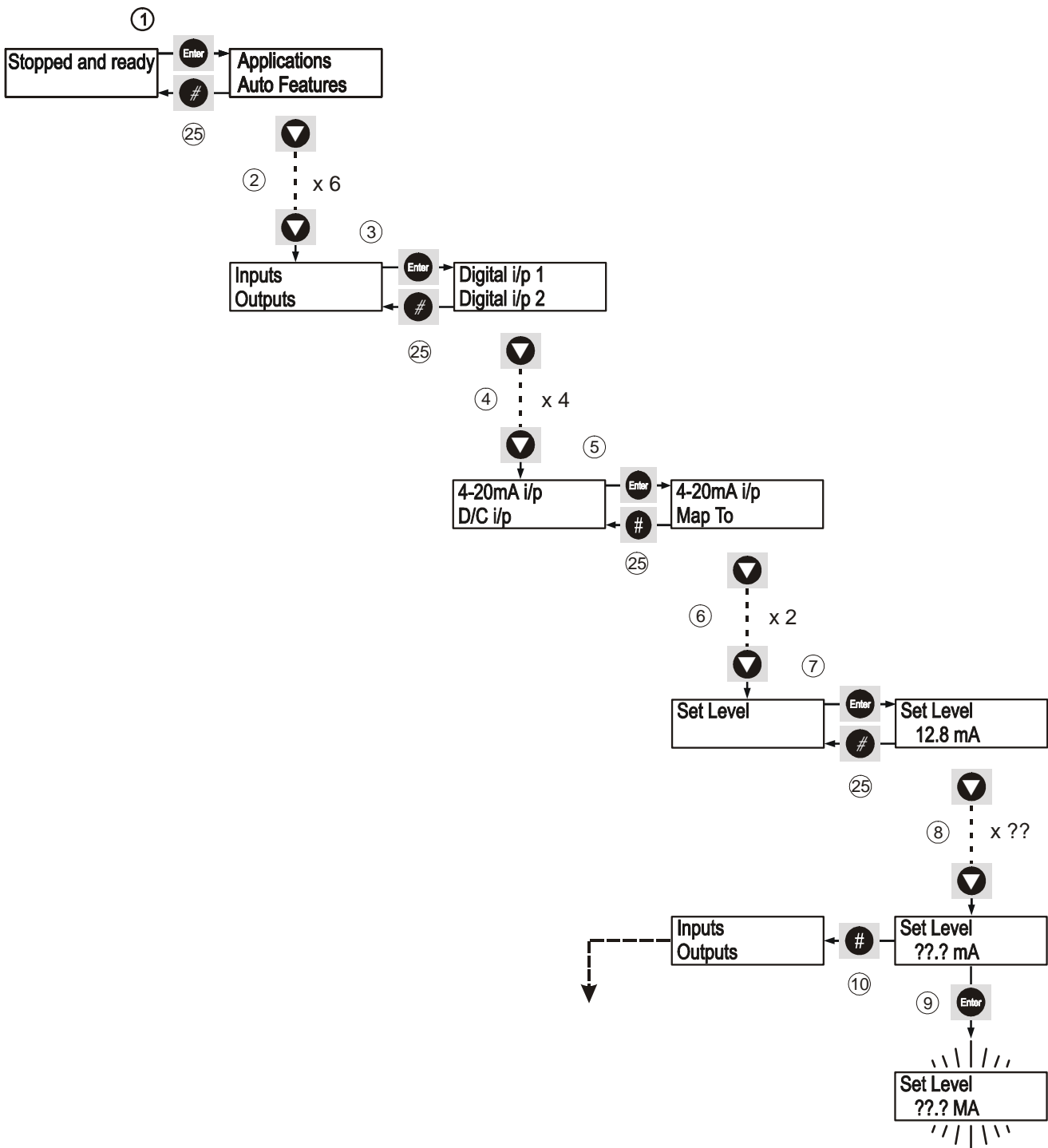

5. Press the **Enter** button.
6. Scroll down with the **▼** button until `Set Level` is on the top line.
7. Press the **Enter** button.
8. Using the **▲** and **▼** buttons set the level at which the unit is required to switch over from a zero (0) to a one (1).
9. Press the **Enter** button once to confirm the change.
10. Press the **#** button three times to return to the `Inputs` menu.
11. Press the **▼** button until `Outputs` is on the top line of the display.
12. Press the **Enter** button.
13. With `Led` on the top line, press the **▼** button until `K3` is on the top line.

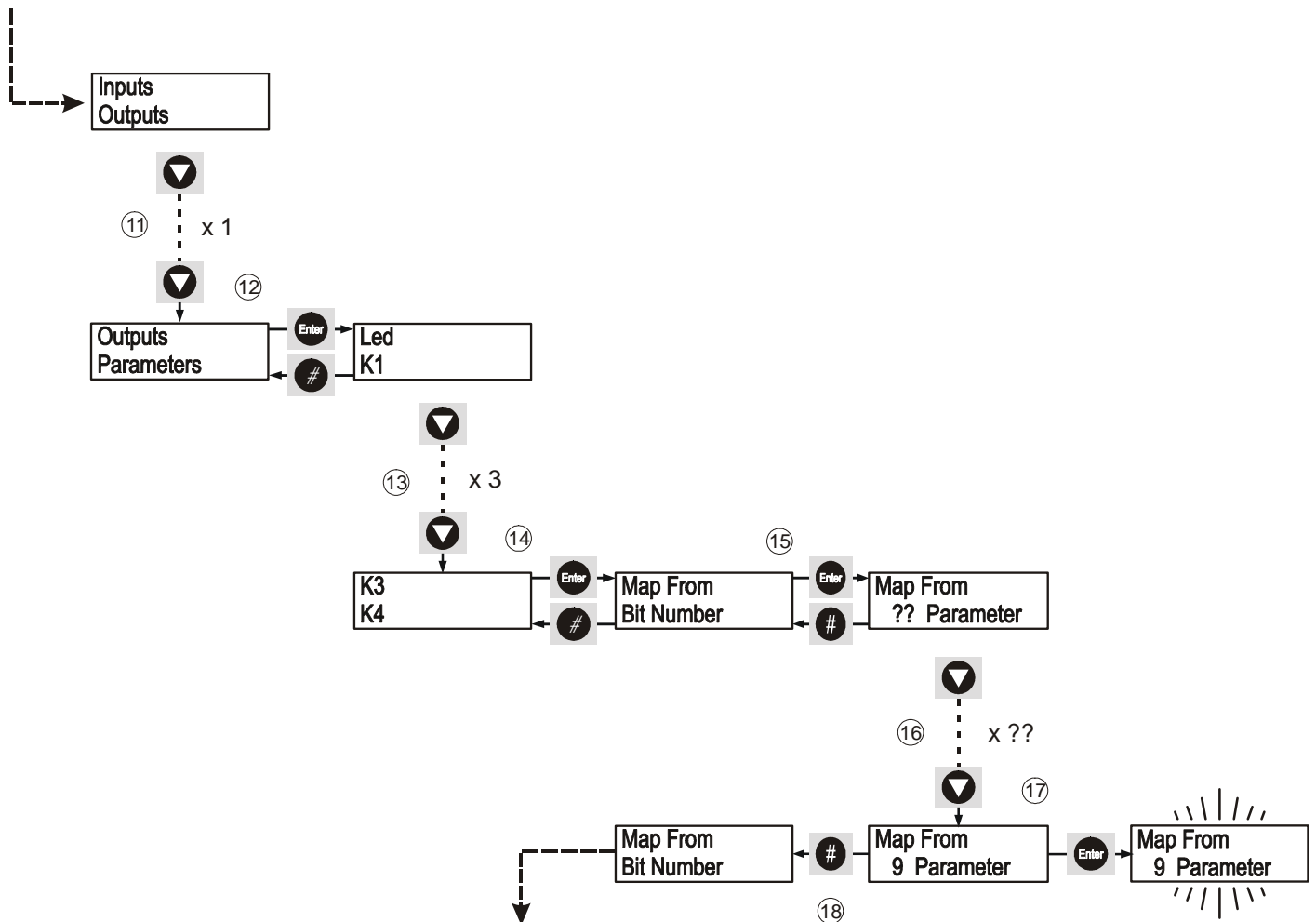

14. Press the **Enter** button.
15. With `Map From` on the top line, press **Enter**.
16. Make sure that `9 Parameter` is showing, use the **▲** and **▼** buttons to change the display until it is showing.
17. Press **Enter** once to confirm the change.
18. Press **#** once to return to `Map From`.

19. Press the ▼ button until Bit Number is on the top line of the display.
20. Press the **Enter** button once to select Bit Number.
21. With the cursor on the LSB, press the ▼ button once to change the bit value to zero (0).
22. Press the **Optimize** button seven times to move the cursor to bit 7.
23. Press the ▲ button once to change the bit state of bit 7 to one (1).
24. Press **Enter** once to apply the changes. The display will flash once to confirm the change has been accepted.
25. Press # four times to return to Stopped and ready.

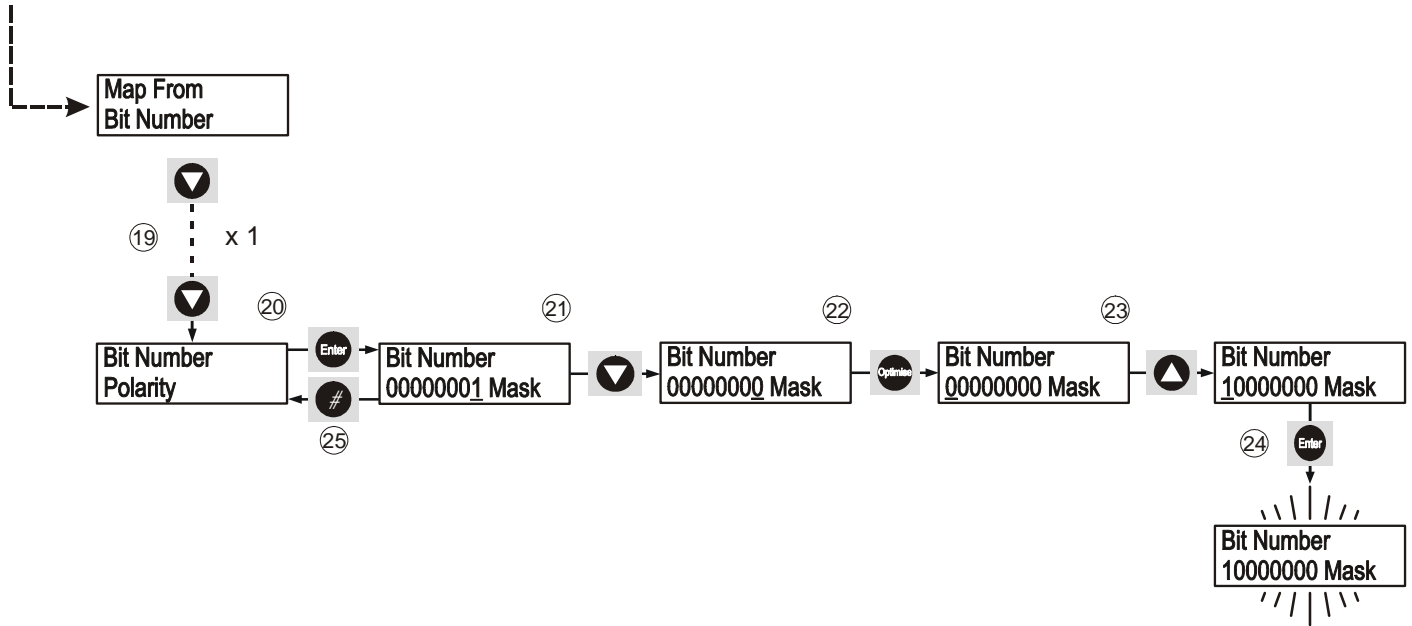

Please remember to keep the above settings they must be permanently saved. See section 5.4.5

5.5.9 Using the DC input to set a parameter's value, (applies to plus units only).

In this example the *Start Time* (P12) is adjusted by means of the 0-10v DC Programmable Input. The following instructions describe how to program the input for this type of application.

1. With *Stopped* and *ready* displayed, press the **Enter** button once.
2. With *Applications* at the top of the display, press the ▼ button until *Inputs* shows on the top line of the display.
3. Press **Enter** once.
4. With *Digital i/p 1* showing, press the ▼ button until *DC i/p* is on the top line of the display.
5. Press **Enter** once.
6. Scroll down with the ▼ button until *Map To* is on the top line of the display.
7. Press **Enter** once.
8. Using the ▲ and ▼ buttons select *12 Parameter*.
9. Press **Enter** to apply the change. The display will flash once to confirm the change has been accepted.
10. Press # four times to return to *Stopped* and *ready*. Adjusting the DC i/p will now adjust the start time.

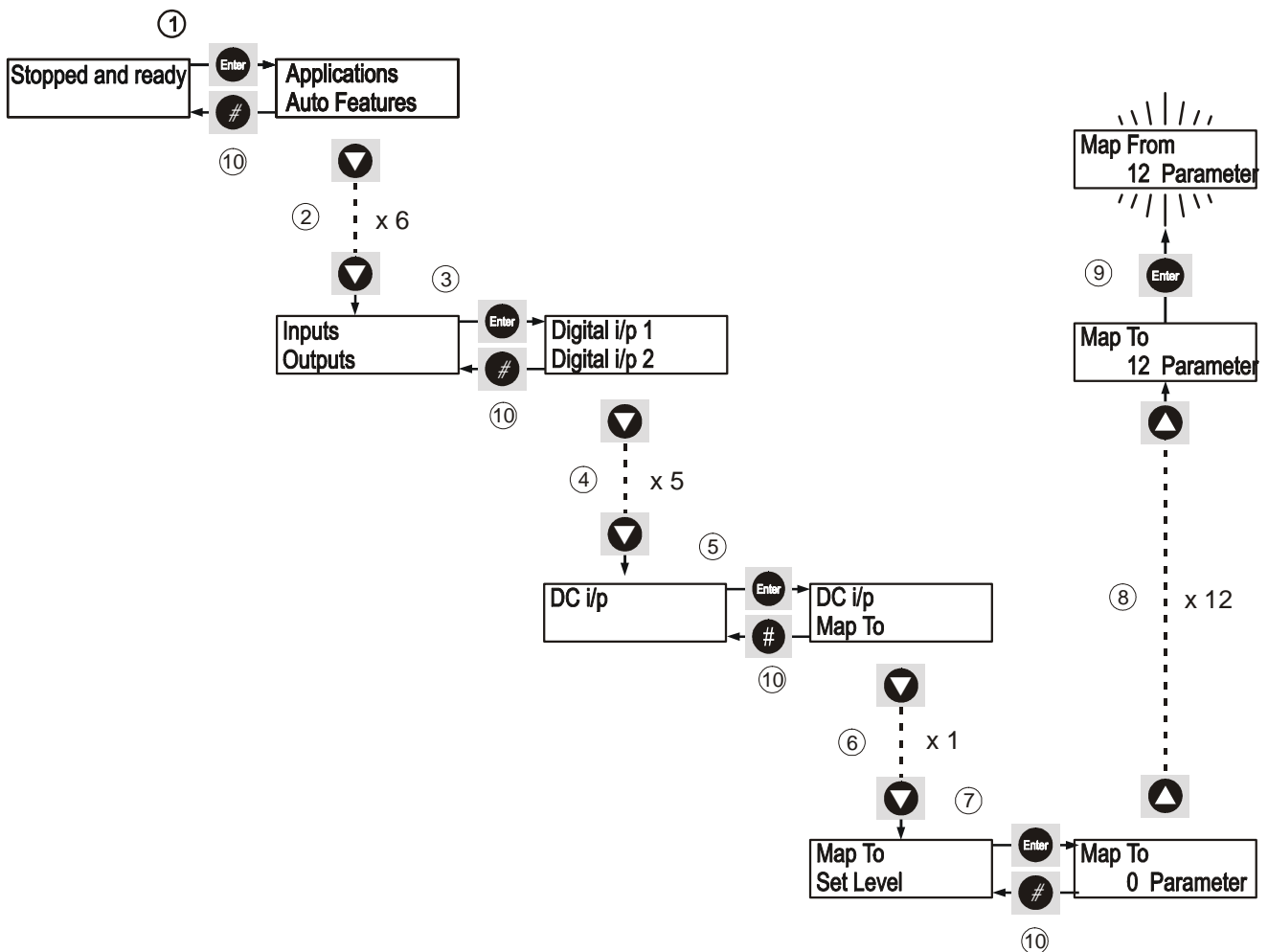

Please remember to keep the above settings they must be permanently saved. See section 5.4.5

5.5.10 Mapping the Load Current to Analogue Output 2, (applies to plus units only).

In this example the user will be able to take some real-time information from the unit and transfer it to the outside world in the form of an analogue signal.

1. With `Stopped` and `ready` displayed, press the `Enter` button once.
2. With `Applications` at the top of the display, press the `▼` button until `Outputs` appears on the top line of the display.
3. Press the `Enter` button once.
4. With `Led` on the top line of the display, press the `▼` button until `Analogue o/p 2` appears on the top line.
5. Press the `Enter` button once.
6. Use the `▲` or `▼` buttons to select `26 Parameter`.
7. Press `Enter` to apply the change. The display will flash once to confirm the change has been accepted.

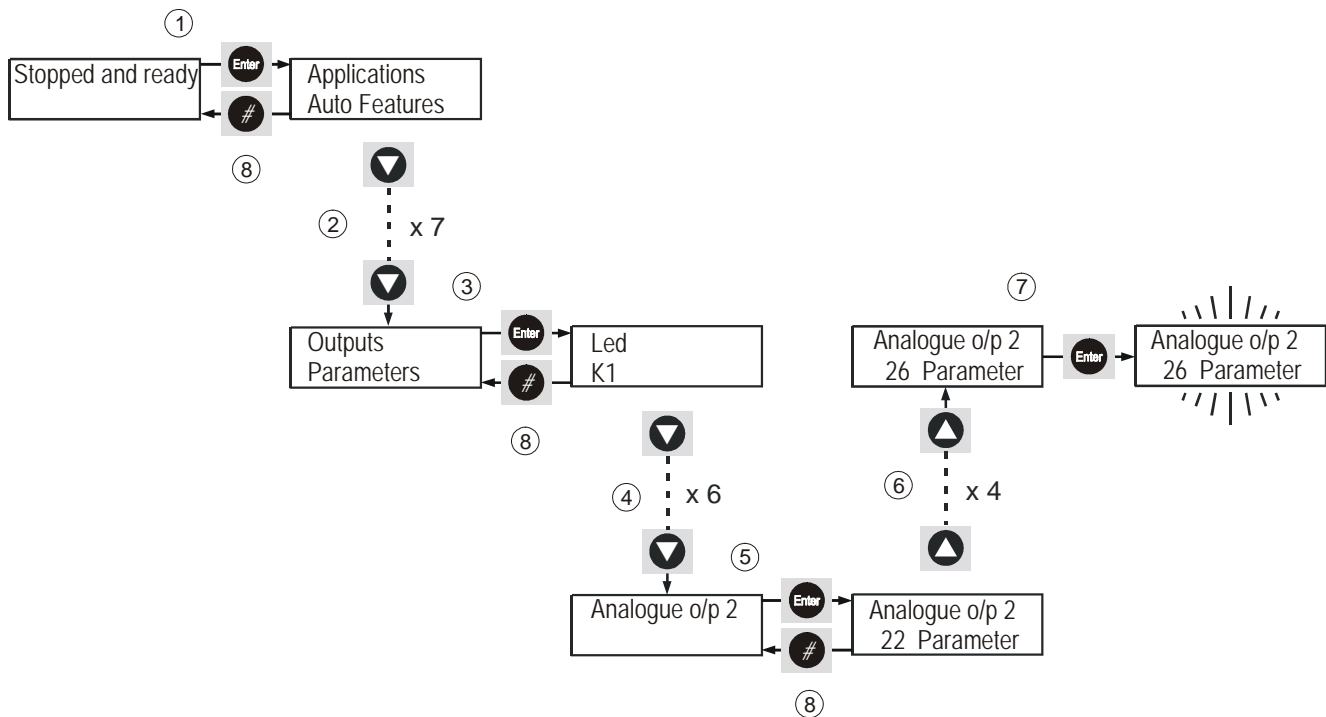

8. Press the `#` button three times to return to `Stopped` and `ready`.

Please remember to keep the above settings they must be permanently saved. See section 5.4.5

5.5.11 Mapping Programmable Input 2 to the User Trip, (applies to plus units only).

This example shows the user how to program the SFE3 to accept a trip input from an external source.

1. With *Stopped* and *ready* shown on the display press the **Enter** button once.
2. With *Applications* shown on the top line of the display press the **▼** button until *Inputs* is shown on the top line.
3. Press the **Enter** button once to select the *Inputs* menu.
4. With *Digital i/p 1* on the top line of the display, press the **▼** button until *Digital i/p 2* is displayed.
5. With *Digital i/p 2* on the top line of the display, press the **Enter** button once.
6. With *Map To* on the top line of the display, press the **Enter** button once.
7. With *0 Parameter* showing, press the **▲** button until *53 Parameter* is displayed.
8. Press the **Enter** button once to confirm the change, the display will flash once in acknowledgement.
9. Press the **#** button once to return to *Map To*.

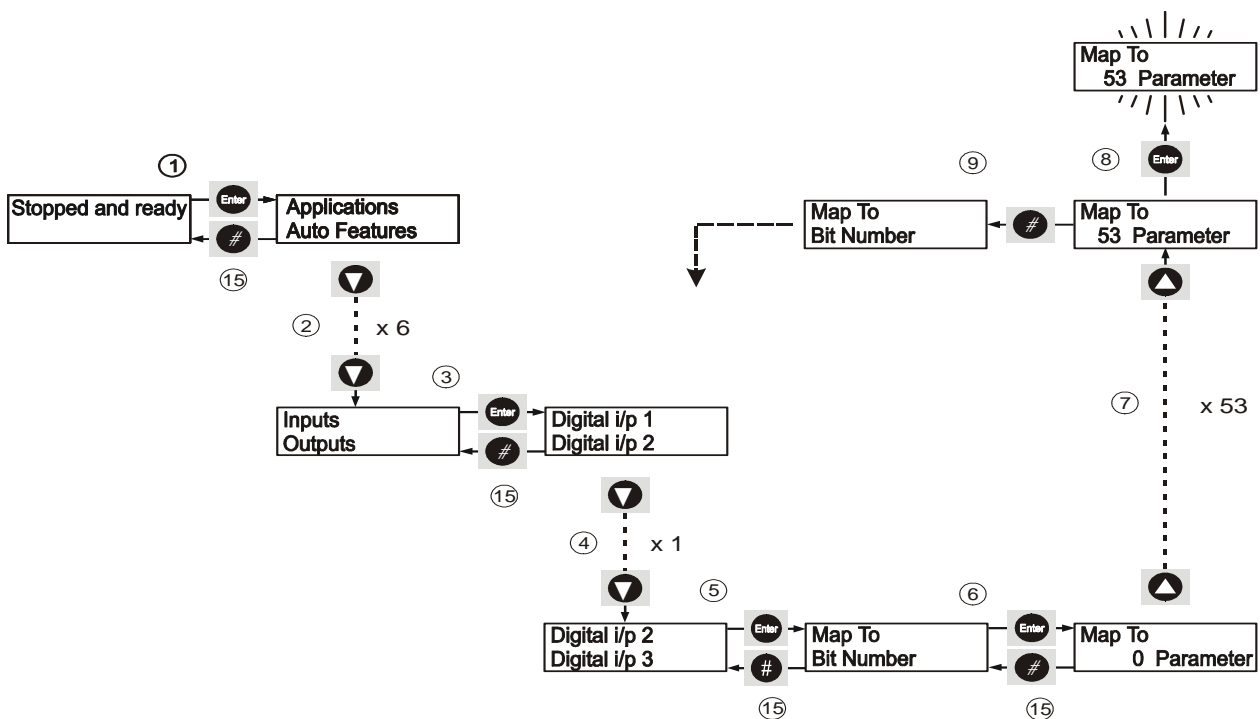

10. With `Map To` on the top line of the display press the **▼** button once until `Bit Number` is displayed on the top line.
11. Press the **Enter** button once to select `Bit Number`.
12. Press the **Optimize** button three times so the cursor key moves to bit three.
13. Press the **▲** button once to change the bit state to one (1)
14. Press the **Enter** button once to confirm the change, the display will flash once in acknowledgement.
15. Press the **#** button four times to return to `Stopped` and ready.

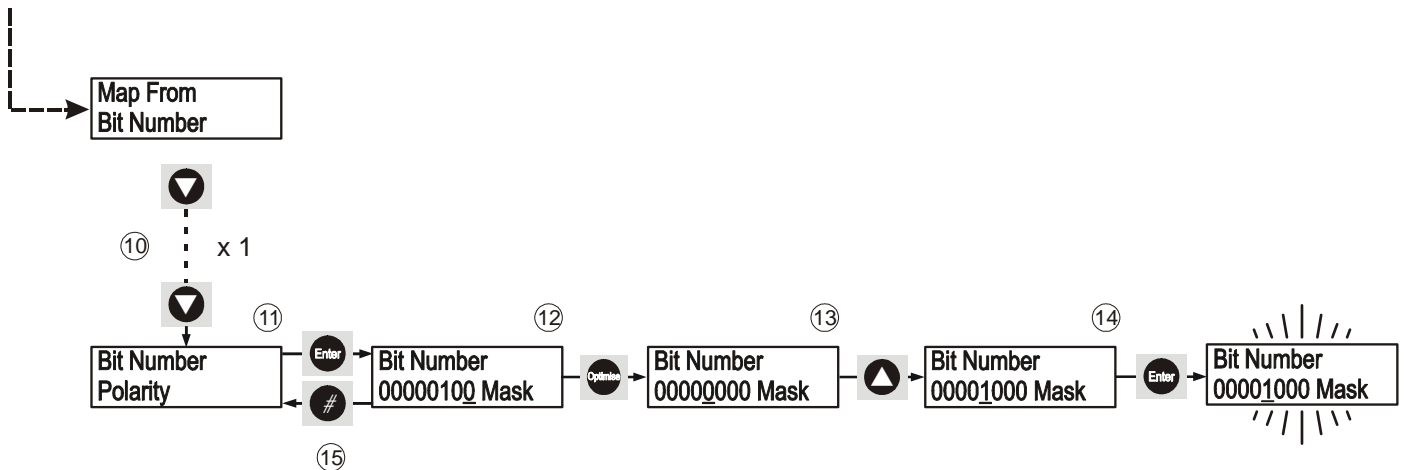

Please remember to keep the above settings they must be permanently saved. See section **5.4.5**

5.6.1 Definitions

Auxiliary Function Card

An optional expansion card that extends the functionality of the SFE3. See the Electrical Installation Manual, sections **2.5.4**, **2.7.2** and **2.7.4**.

Dwell

This is the period between **Top of Ramp** and **Run** which is designed to give unstable loads a chance to settle down.

Index Rating

The **Index Rating** defines the duty of the starter. For a fuller explanation of the term please refer to TF0120 available on the website.

Jog

Small movements of a three phase induction motor usually used when commissioning the motor or load.

Keypad

The keypad is the internally mounted user interface. Through this interface the user can start/stop, program and query the unit's status. Fitting of the keypad precludes fitting of the keypad.

Keypod

The keypod is the externally mounted user interface. It can be mounted at a maximum distance of 10 metres from the unit. Through this interface the user can start/stop, program and query the unit's status. Fitting of the keypod precludes fitting of the keypad.

Kick Start

This is an optional extra 'kick' of voltage to start 'sticky' loads.

Load Current

The current drawn by the application or load.

Optimise

This is an optional energy saving feature. Refer to section **3.4** of the **Applications** manual for a detailed explanation.

Overload

An **Overload** is a sustained over-current, with a duration of seconds or minutes rather than cycles, but generally drawing less current than a **Shearpin**, that might or might not end in a trip. Changes in the load characteristics might cause an overload.

Parameter

A parameter is a menu item that directly relates to an internal parameter of the soft starter.

Plus Unit

A SFE3 that has had the Auxiliary Function Card (also known as add-on card) fitted.

Rated Current

This is the nominal current (in Amps) that the unit has been designed to run at.

Shearpin

Shearpin is also an over-current but of a much shorter duration, cycles rather than seconds, and is generally a higher current than an **Overload**.

Stall

The point at which the load placed on a motor threatens to stop a motor's rotational movement.

5.6.1 continued

Static

Static as in static loads. This term refers to loads with no moving parts, so induction motors, linear motors etc... are non static loads. An example of a static load would be a resistor bank.

Top of Ramp

This is the point at which the soft starter reaches maximum output voltage.

Unit Full Load Current

This is another name for the **Rated Current** of the unit.

Writeable Parameters

A parameter that can be written to by the user as well as being read by the user, as opposed to a read-only parameter which can only be read by the user.

Soft Starters and Energy Optimising Soft Starters

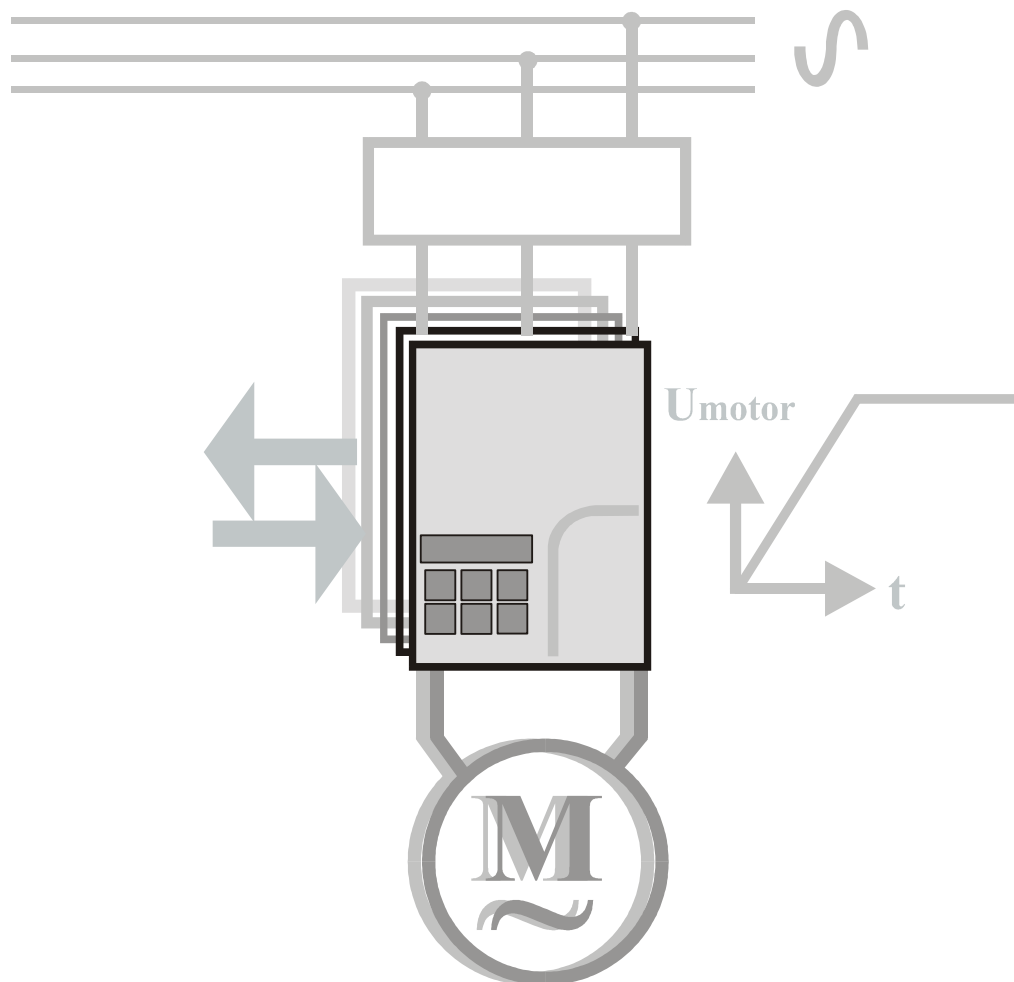

Technical Data for 5MC Based Soft Starters

Modbus Protocol Manual FD5100 issue07

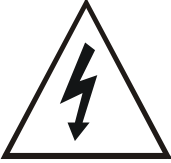
	The owner, installer and user is responsible for the correct installation and use of the 5MC and must ensure that only qualified personnel install the 5MC and that the installation, operation and maintenance of the unit complies with the relevant Codes of Practice, Regulations and Statutory Requirements. The Manufacturer or his agent do not assume any liability, expressed or implied, for any consequence resulting from inappropriate, negligent or incorrect installation, application, use or adjustment of the product or circuit design, or from the mismatch of the unit to a motor. To prevent an electrical shock hazard the 5MC must be connected to a safety earth. The unit is not designed for use in hazardous areas. Use in such an area may invalidate the hazardous area certification.
WARNING	

© 2008 by Fairford Electronics, all rights reserved

Copyright subsists in all Fairford Electronics deliverables including magnetic, optical and/or any other soft copy of these deliverables. This document may not be reproduced, in full or in part, without written permission. Enquiries about copyright of Fairford Electronics deliverables should be made to Fairford Electronics, Coombe Works, Derby Road, Kingsbridge, Devon TQ7 1JL.

If, by permission of the copyright owner, any part of this document is quoted, then a statement specifying the original document shall be added to the quotation. Any such quotation shall be according to the original (text, figure or table) and may not be shortened or modified.

6	The Modbus Protocol	5
6.1	Overview	5
6.2	Quick Start	5
6.3	Specification	6
6.4	Function 03 - Read holding registers	7
6.5	Function 05 - Preset Single Coil	7
6.6	Function 06 - Preset Single Register	8
6.7	Function 07 - Exception status	8
6.7	continued	9
6.8	Function 16 - Preset Multiple Registers	9
6.9	Returned Errors	10
6.10	5MC Commands	11

6 The Modbus Protocol

6.1 Overview

The 5MC has built in serial communications this has been changed from Version 55 onwards to be a compatible subset of the widely recognised Modbus RTU protocol (slave).

The serial communications is accessible from the keypad connector or with an additional interface card (RS485) the 5MC may be connected to a PC or suitable PLC network.

6.2 Quick Start

Work should only be carried out on the 5MC with all electrical power disconnected

- 1) Communication settings
 - a) 9600 baud, 8 databits, 1 stop bit, no parity
 - b) network station number = 1

- 2) Before Connecting a Comms interface use the standard keypad to make any changes for your bus system.
 - a) Set parameter 1 to the required network station number (slave address) now unless station 1 is spare on the network.
 - b) If not continuously polling the unit at least once every 2 seconds set PNU126 to 0 turning off comms timeout trip
 - c) Make any changes to Parameter 121, \$20 (Coil 974).
0 = 1 Stop bit
1 = 2 Stop bits
 - d) Store changes to eeprom (save ram).

- 3) The 5MC standard keypad **MUST BE DISCONNECTED** while any optional communication interface is fitted unless the interface provides a suitable connector. See the relevant application note (APP00002) for connection of the various interface cards.

- 4) Details of registers and Flags are available in the FD8416 series of documents.

- 5) Register and coil addresses start at zero; register zero is addressed as zero, **register one is addressed as one ...**
Allowed address ranges are Register numbers 0...127, EEPROM Registers 1000...1127, Coils (flags) 0...1024.

- 6) Registers are mapped one to one, that is register one on the keypad is register one on the Modbus.

- 7) Flags on the Modbus are read as holding registers i.e. read register 9 to read status2 flags. For writing flags are mapped one to one so for example the the Kick Start Flag bit 0 of User Flags 1 (P51) is bit no $51 * 8 + 0 = \text{Flag } 408$.

6.3 Specification

1. Refer to Modicon Modbus Protocol Reference Guide PI-MBUS-300 for full protocol specification.
2. Baud rate is 9600.
3. 8 data bits, no parity, 1 stop (default) or 8 data bits, no parity, two stop bits.
4. Modbus timeout is 3.5 character times, the in message timeout is also 3.5 character times unlike the standard which is 1.5 character times. Further it is also possible that the 5MC will be appreciably delayed in responding to a telegram if it is checking a fault condition.
5. Broadcast is not supported.
6. 5MC parameters retain their normal numbers (0-127).
7. Flag parameters are bit positions starting at parameter 0 bit 0
8. Register numbers are 0...127
9. Coils (flags) 0...1024
10. Offline eeprom Registers are 1000...1127
11. Supports

Function 03 read holding registers up to 4 words (8 parameters) in number.

Function 05 preset single coil.

Function 06 preset single register (byte).

Function 07 exception status.

Function 16 preset multiple registers upto 3 words (6 parameters).

Error 01 illegal function (write to read only parameter)

Error 02 illegal data address (bad parameter number)

Error 03 illegal data (trying to read or write too much data)

Error 06 slave busy

Error 07 negative acknowledge

6.4 Function 03 - Read holding registers Starter 01 PNU 01, 02

This function is used to read a group of up to eight parameters from the 5MC.

The allowable address range for this function is 0-127 for working parameters and 1000 – 1127 for offline eeprom parameters.

5MC parameters are bytes, Modbus reads the values from the slave as words so to speed up communications two 5MC parameter bytes are packed into each Modbus word. The lowest parameter is in the data Hi of the word and the next parameter is in the data Lo. This also means that even when the read request is for one register two 5MC parameters are read, up to 4 contiguous words (8 parameters) may be read with one query.

Modbus function 3 transaction table

Query	
Field	Hex Byte
Slave Address	01
Function	03
Start Address Hi	00
Start Address Lo	01
No of registers Hi	00
No of registers Lo	01
CRC Lo	??
CRC Hi	??

Response	
Field	Hex Byte
Slave Address	01
Function	03
Byte Count	02
Data Hi	01
Data Lo	2C
CRC Lo	??
CRC Hi	??

6.5 Function 05 - Preset Single Coil Starter 01 coil (flag) 408

This function is used to set or clear a single Flag, a flag is a bit within parameters 0-127. Only flags in parameters known internally to be flag registers and marked for read write may be preset with this function. Therefore the range of available flags is 0-1024.

The normal response for correct operation is an echo of the data. This function is only available for software versions 56 and 67

Modbus function 5 transaction table

Query	
Field	Hex Byte
Slave Address	01
Function	05
Coil Address Hi	01
Coil Address Lo	98
Force Data Hi	FF
Force Data Lo	00
CRC Lo	??
CRC Hi	??

Response	
Field	Hex Byte
Slave Address	01
Function	05
Coil Address Hi	01
Coil Address Lo	98
Force Data Hi	FF
Force Data Lo	00
CRC Lo	??
CRC Hi	??

6.6 Function 06 - Preset Single Register Starter 01 PNU 12, Data 09

This function is used to set the value of a single parameter. **It differs from the modbus protocol** in that only the data Lo byte of the query is written to the parameter address. The data Hi byte is ignored.

The normal response for correct operation is an echo of the data.

Modbus function 6 transaction table

Query	
Field	Hex Byte
Slave Address	01
Function	06
Address Hi	00
Address Lo	0C
Force Data Hi	00
Force Data Lo	09
CRC Lo	??
CRC Hi	??

Response	
Field	Hex Byte
Slave Address	01
Function	06
Address Hi	00
Address Lo	0C
Force Data Hi	00
Force Data Lo	09
CRC Lo	??
CRC Hi	??

6.7 Function 07 - Exception status Starter 01

This functions format is as per the modbus standard but the bits in the value returned have different meanings shown below. This is the quickest of the modbus functions and should be used in the context of the 5MC to check if a station is present or check if it is busy

Modbus function 7 transaction table

Query	
Field	Hex Byte
Slave Address	01
Function	07
CRC Lo	41
CRC Hi	E2

Response	
Field	Hex Byte
Slave Address	01
Function	07
Exception Data	00
CRC Lo	??
CRC Hi	??

6.7 continued

Returned Exception Data

Bit	Meaning
0	Enabled
1	Stopped
2	Starting
3	Current Limiting
4	TOR (Start Complete)
5	Cooling
6	Alarm
7	Offline Command Failed

6.8 **Function 16 - Preset Multiple Registers** Starter 01 PNU 10 - 13, Data undefined

This function is used to set the values of multiple parameters. **It differs from the modbus protocol** in that since all parameters are bytes they are packed into the 16 bit register space lowest parameter number to hi byte then the next parameter in the low byte and so on up to 3 contiguous words (6 parameters) may be preset with one query.

Modbus function 16 transaction table

Query	
Field	Hex Byte
Slave Address	01
Function	10
Address Hi	00
Address Lo	0A
No. of Regs Hi	00
No. of Regs Lo	02
Byte Count	04
Data Hi	??
Data Lo	??
Data Hi	??
Data Lo	??
CRC Lo	??
CRC Hi	??

Response	
Field	Hex Byte
Slave Address	01
Function	10
Address Hi	00
Address Lo	0A
No. of Regs Hi	00
No. of Regs Lo	02
CRC Lo	??
CRC Hi	??

6.9 Returned Errors

If there is a communication error in the query the 5MC does not reply.

If the network communication is Ok but for some reason the 5MC cannot correctly execute the query then it will return an error reply. In an error reply the function byte is returned OR'ed with \$80 and the following byte contains the error number. The table below shows the query/reply that would be expected if the slave was busy

Modbus function 7 transaction table showing error response

Query	
Field	Hex Byte
Slave Address	01
Function	07
CRC Lo	41
CRC Hi	E2

Response	
Field	Hex Byte
Slave Address	01
Function	87
Exception Data	06
CRC Lo	??
CRC Hi	??

Number	Modbus	Meaning
1	Illegal Function	Writing
2	Illegal Data Address	Out of allowed parameter range
3	Illegal Data	Too many data bytes in query
6	Slave Busy	Slave is performing a long command

6.10 5MC Commands

The 5MC Modbus series software has a new mechanism for carrying out common functions or offline ones which take a long time and requires the 5MC to be off and disabled. Commands are now carried out by writing various values to a Command Register (parameter 124). For example writing a 1 to PNU124 using function 6 disables the starter

Once a value has been written to This special register further Modbus queries will receive an error "slave busy" until the command execution is completed. If an error occurred during the execution of the command (say the unit was not disabled before execution) then the Offline Command failed flag will be set. If function 7 has been used to poll the 5MC then once the busy period is over this flag is available in the returned status byte position \$80.

Parameter 124 Command Codes

Number	Command	Active	Meaning
1	Disable Starter	Always	Stop the 5MC responding to start commands, remote or local. If running the 5MC will stop immediately. The status of any start signal is not changed.
2	Enable Starter	Always	The 5MC will respond to new or existing start commands
3	Bus Starting	Always	The 5MC responds to start requests from the keypad/Bus port.
4	Remote Starting	Always	The 5MC responds to start requests from the hardware input
5	Reset Starter	Always	The 5MC is forced to a cold start
6	Reset Trip	Always	Resets the 5MC to stopped and ready state
7	Bus Start	When Enabled	If Starting = bus & unit is enabled, 5MC will start
8	Bus Stop	When Enabled	5MC will always stop
9	Factory Default	When Disabled	The working ram is loaded with factory default values, this may take up to 5 seconds
10	Power On Default	When Disabled	The working ram is loaded with the permanent store values
11	Save ram	When Disabled	The working ram is saved to the permanent store for future use, this may take up to 5 seconds

Modbus Communications – RS485 Add On Card for the SFE3/XFE Range of Soft Starters

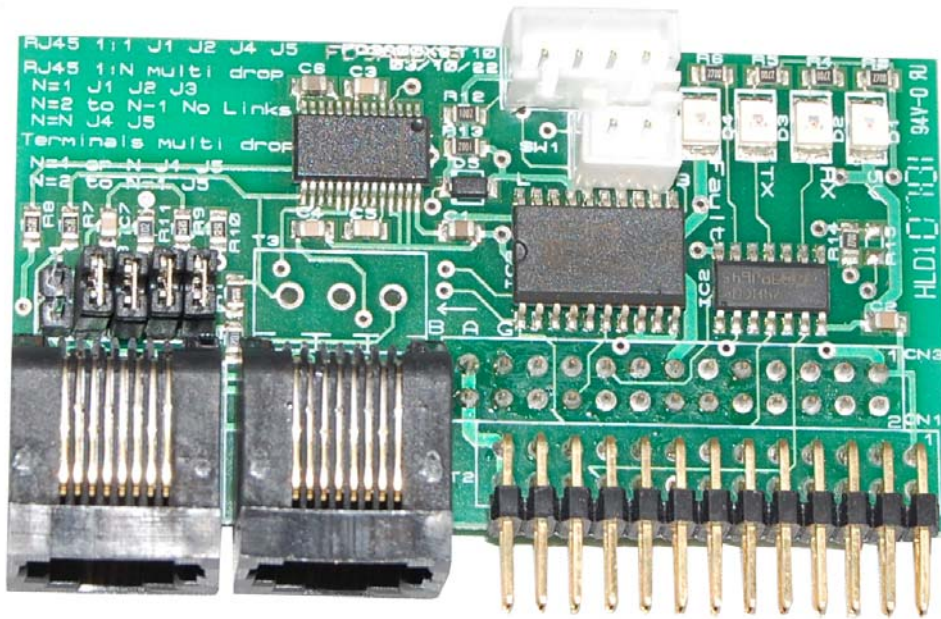

The ability to set up, control and monitor single or multiple SFE3/XFE Soft starters has now been introduced.

With the addition of the AP9A00 serial card it now allows control to be switched between an integral Keypad or alternately through an external isolated Modbus network.

Modbus Communications for the SFE3/XFE range of Soft Starters

- The AP9A00 is for use with version 5511 or above firmware.
- It provides an RS485 interface with 50V isolation for demanding industrial applications.
- The interface is suitable for connection to the Remote Keypad or a standard Modbus networks running at 9600 baud 8N1.

Communications Technical Specification

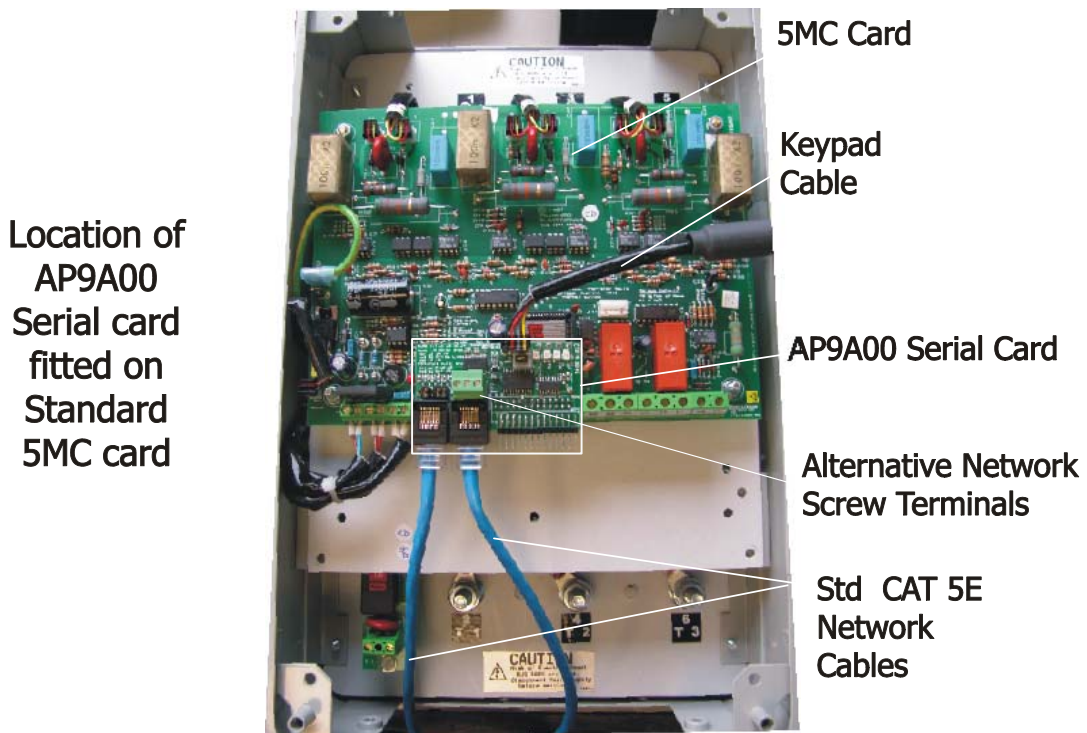

Network Application AP9A00 fitted with screw terminal and using twisted pair cabling

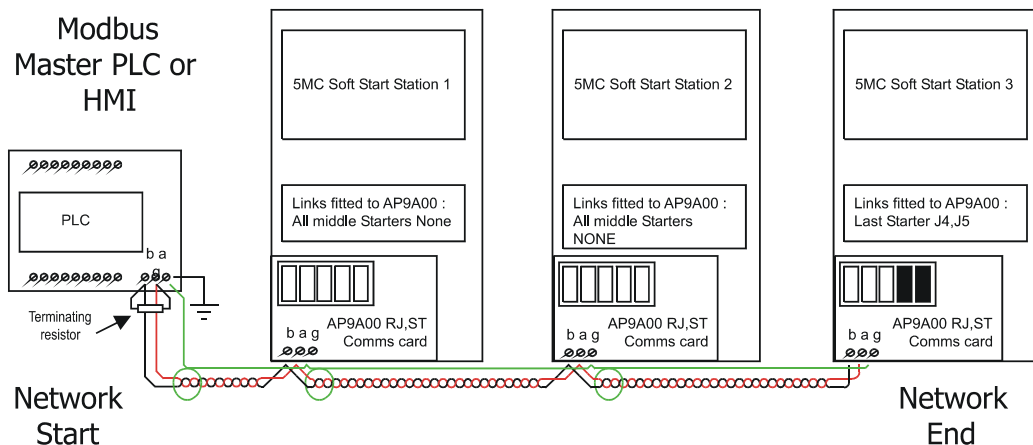

SD0008702

Remote Keypod for the SFE3/XFE Range of Soft Starters



Easy Installation - Easy Set Up – Reliability

Panel mounting

The Keypod is invaluable for multiple installations and can eliminate many control items.

Remote Keypod For the SFE3/XFE Range of Soft Starters

- Can be used on a one to one basis, or one Keypod can control several Soft Starters
 - Seven buttons with individual Start and Stop
 - Display via a 2 line 32 character LCD
- Eliminates panel mounted Start and Stop push buttons, Ammeters, Run, Top of Ramp and Alarm Lamps
- The Keypod gives continuous display of motor phase current and control status Starting, Stopping, Full Volts, Optimising, Current Limitation, Overload and Fault Indication

Keypod Concept

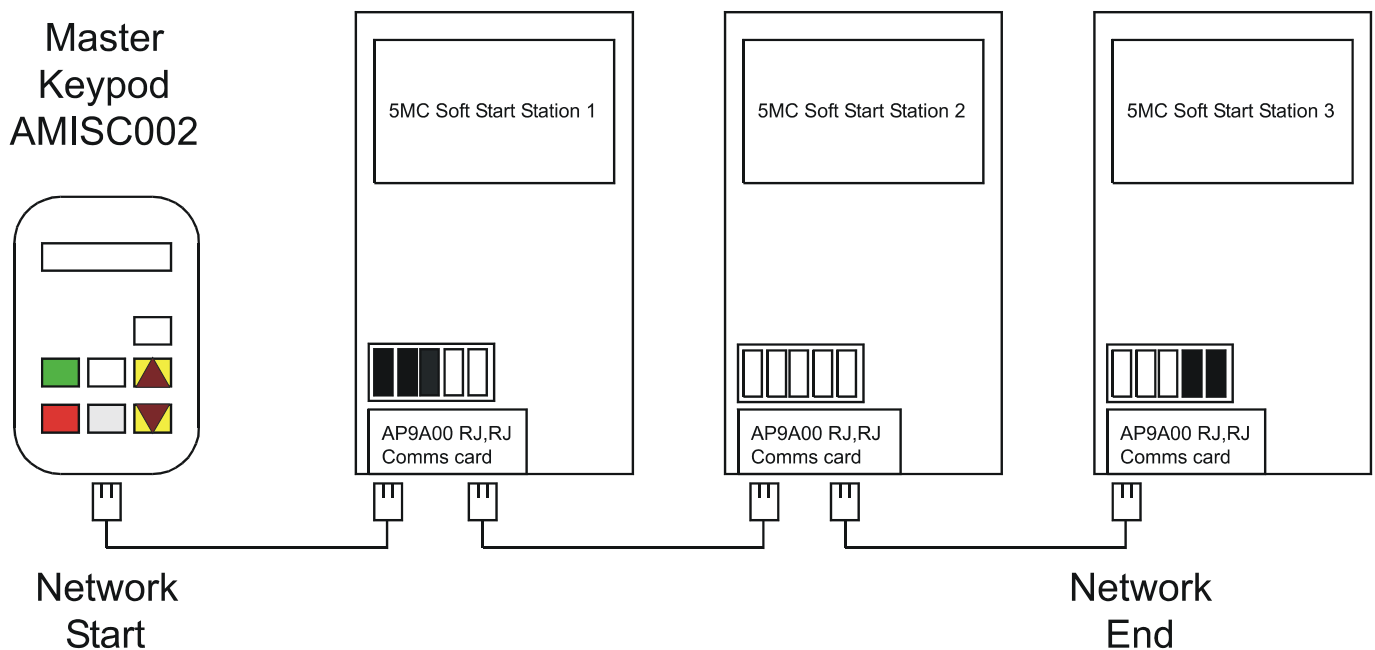



5MC SoftStarters, as standard are controlled by a Modbus serial protocol (see FD5100 Modbus Manual). The addition of an AP9A00 Serial card allows this control to be switched between the integral keypad or alternatively through an external isolated RS485 network.

The AP9A00 circuit board and AMISC002 Keypad have been designed to connect via a standard CAT5 RJ45 terminated ethernet cable. Additionally the AP9A00 is fitted with a second RJ45 connector allowing a number of soft starters to be connected together. Alternatively standard twisted pair wiring may be used via the secondary screw terminals. When specifying a Simple Starter Network 3 main parts are required

- 1: SoftStarts fitted with AP9A00 comms cards.
- 2: Modbus Master or AMISC002 Keypad.
- 3: Cabling

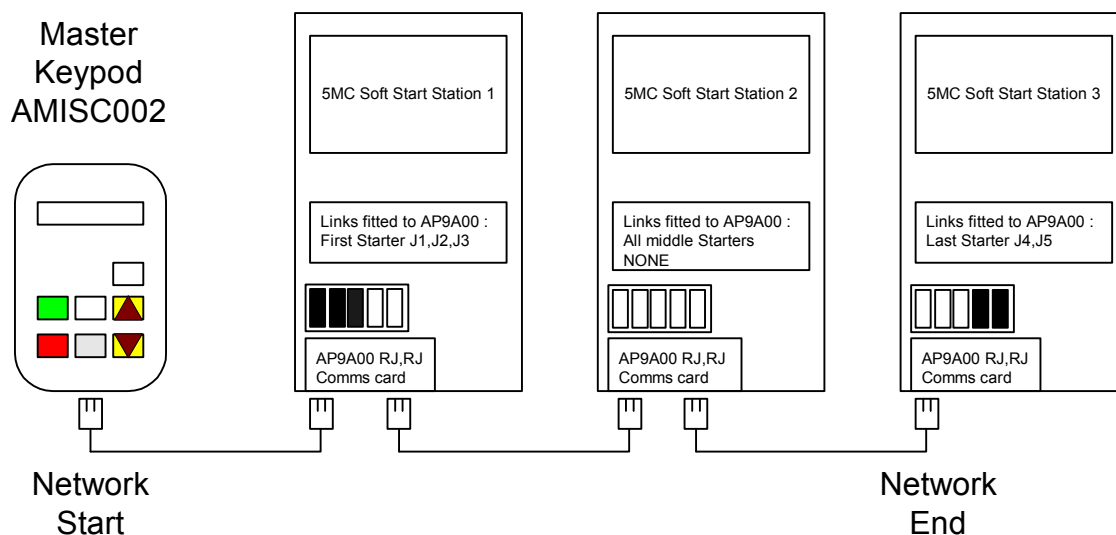

Network Application AP9A00 fitted with screw terminal and using twisted pair cabling

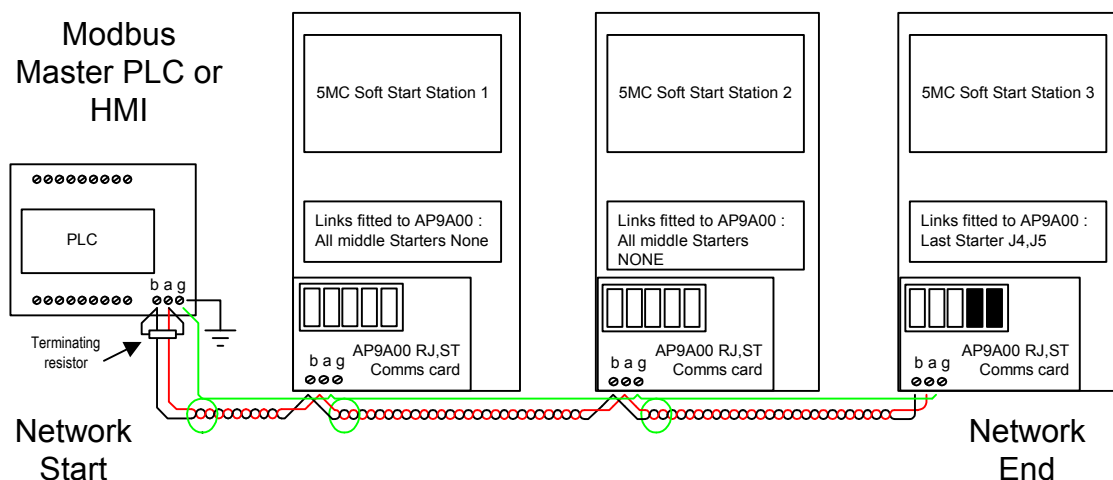



J1 –J5 Link Options

- L1: when linked 12V is passed through to the RJ45 connectors. This is for use with the FE net only, it supplies power to the remote Keypod, even then only the unit closest to the Keypod should have this link fitted.
- L2: when linked the on board 1k grounding resistor is shorted out. This is for use with FE net only, even then only the unit closest to the Keypod should have this link fitted.
- L3: when linked the serial comms isolated ground is connected to the local unit ground. If multiple MAX3157 (isolated comms) chips are connected one must have this link shorted.
- L4: when linked a 100 ohm terminating resistor is connected between the A and B RS485 lines on both the RJ45 and screw terminal connections. For RS485 networks only the nodes at each physical end of the network have terminating resistors fitted.
- L5: when linked a 1k resistor is connected between screw terminal G and local ground. Normally only one of the units would have this link fitted.
- For Keypod RJ45 1 to 1 connection with starter fit links 1,2,4,5
- For PLC/HMI twisted pair connection 1 to 1 with starter fit terminating resistor (may be internal) at PLC/HMI end and links 4 &5 on starter.

1. AP9A00 cards must be version X8+
2. AP9A00 isolation level 50V
3. Maximum number of starters 8
4. 5MC minimum software level 56.09 OR 67.03
5. Keypod minimum software level 1.070
6. Standard settings are 9600 baud,8,n,1
7. Cable RJ45 Twisted pair CAT5 Ethernet
8. Maximum network length must not exceed 25M.
9. The keypod is only able to control one starter at a time.
10. While the keypod is showing the starter status, pressing the up arrow changes to the next connected starter.
11. Most Communication parameters require the unit to be disabled before adjustment is allowed.
12. When initially setting up the network one starter at a time is added and it's **unique** station number must be allocated.
13. It is important to keep the network cabling separate from any power and electric control wiring.
14. On factory fitted units an external switch Local/Remote is provided to switch between internal keypad and external RS485 /Keypod.

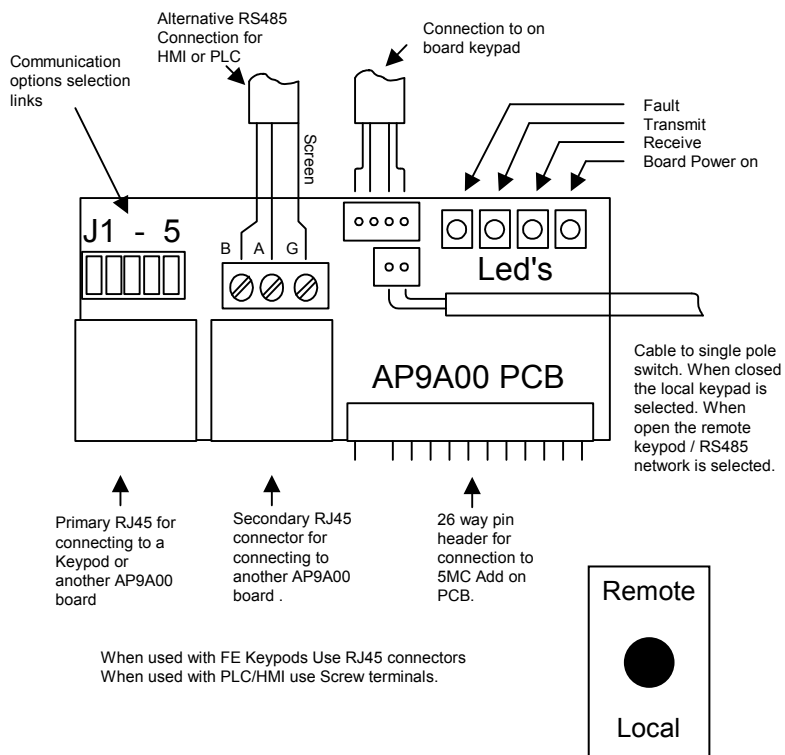

Switch located on side/front of the unit when factory fitted.



AP9A00 Circuit board in fitted position on 5MC card



APCB9A00X8 circuit board

